

DUMPERS DP4200 DP7000
MAINTENANCE MANUAL

 1300 888 479

 sales@dieciaustralia.com.au

 1/5 Melito Court, Prestons NSW

 www.dieciaustralia.com.au

Each machine is provided with:

- Copy of this manual,
- A copy of the use and maintenance manual of the engine prepared by the manufacturer
- A copy of the use and maintenance manual for each device or equipment which is installed on this machine.

These manuals have been prepared by the respective suppliers and are faithfully reproduced in full by **DIECI S.R.L.** Behind their specific authorization: they can be enriched with additional specifications drawn up by **DIECI S.R.L.**



- WARNING

All documentation provided is an integral and essential part of the product and must be kept at the disposal of the operators; they must carefully read what is written in the above mentioned documentation before using it.



- PROHIBITION

Improper, incorrect or unreasonable use of the machine or accessory installed on it is not allowed as also any intervention that alters its structure or function is not allowed.



- PROHIBITION

Reproduction of all or part of the contents of this manual and any multimedia attachment: **DIECI S.R.L.** will protect the rights on them



- CAUTION

A copy of this manual must always be available to the operator on the machine

DIECI

www.dieci.com

DIECI S.R.L.

VIA E. MAJORANA, 2-4

42027 - MONTECCHIO E. (RE) - ITALY

TEL. ++39 0522-869611

FAX ++39 0522-869744

e-mail: info@dieci.com

USE AND MAINTENANCE MANUAL

1. AXH6023/IT - Edition 1
2. 05/2012

ORIGINAL INSTRUCTIONS LANGUAGE:

3. Italian

ORIGINAL INSTRUCTIONS FOR:

- Dumper 4200
- Dumper 7000

Share capital fully paid-up € 10.000.000,00

Companies Register C.R. No. 01283560686 -
Economic and Administrative Index C.R. No. 204278

Tax Code 01283560686 - VAT no. 01682740350



Edition	Version	Date	Prepared by	Approved by	Description
01	00.00	05/2012	Alberto		New layout, update

Dear customer,

congratulations and thank you for choosing a **DIECI**.

This Use and Maintenance Manual has been written to help you fully appreciate your vehicle.

We strongly recommend that you read this manual in its entirety before using the vehicle.

It contains information, advice and important warnings that will help you to fully take advantage of the technical capabilities of the **DIECI**.

You will learn about its features and special practical information in addition to information about its maintenance, driver and operation safety to help maintain your vehicle over time **DIECI**.

We are confident that you will be happy with your new vehicle and we remain at your disposal should you have any further queries.

Sincerely,

Sales Management



CONTENTS

1	INTRODUCTION.....	1
1.1	Manual structure.....	1
1.2	Purpose and content.....	1
1.3	Preservation.....	1
1.4	Addressees.....	1
1.5	Terms, units of measurement and abbreviations used.....	4
1.6	Used symbols.....	6
2	GUARANTEE.....	8
2.1	Exclusions from the guarantee.....	8
2.2	Guarantee: duration.....	8
2.3	Guarantee: validity.....	8
2.4	Guarantee: activation.....	9
2.5	Guarantee: validity.....	9
2.6	Guarantee: intervention request.....	10
2.7	Non-activation, failure to honour, termination.....	10
2.8	Final terms.....	11
3	SAFETY REGULATIONS.....	12
3.1	General warnings.....	12
3.2	Safety indications.....	13
3.3	Personal protective devices.....	14
3.4	Preparing for accidents.....	16
3.5	Preventing fires and accidents.....	18
3.6	Storing dangerous liquids.....	22
3.7	Warnings for safe working.....	23
4	GENERAL INFORMATION.....	31
4.1	General.....	31
4.2	Identification of the machine.....	32
4.3	Intended use.....	33
4.4	Contraindications for use.....	33
4.5	Declaration of first test.....	33
4.6	Liability.....	33
4.7	Manufacturer.....	34



4.8	Service Centers.....	34
4.9	Certification and CE marking.....	34
4.10	General warnings.....	36
5	MACHINE DESCRIPTION.....	38
5.1	Main components position.....	39
5.2	Technical data.....	47
6	SAFETY DEVICES.....	53
6.1	Safety stickers.....	53
6.2	Parking brake switch.....	61
6.3	Gear selection lever.....	61
6.4	Emergency stop switch.....	61
6.5	Anti-accidental operation devices.....	62
6.6	Seat.....	62
6.7	ROPS - FOPS Cab.....	63
7	COMPONENTS DESCRIPTION AND USE.....	64
7.1	General warnings for use.....	64
7.2	Central instrument panel.....	65
7.3	Gear selection lever.....	67
7.4	Multifunction lever.....	68
7.5	Pedals.....	70
7.6	Pressure gauge *.....	71
7.7	Driver's seat reversal pedal.....	72
7.8	Power steering reversal lever.....	72
7.9	Emergency lights switch.....	73
7.10	Rotating light switch.....	73
7.11	Front window wiper.....	73
7.12	Rear window wiper.....	73
7.13	Slow/fast gear shift button.....	74
7.14	Parking brake switch.....	75
7.15	Steering mode control lever.....	76
7.16	Hand throttle control lever.....	78
7.17	Dump body lifting control lever.....	79
7.18	Door *.....	80
7.19	Glass on engine side *.....	81

7.20 Heating *	81
7.21 Air Conditioning (A/C) *	81
8 DESCRIPTION OF COMPONENTS	82
8.1 Tyres	82
8.2 Fuel	85
8.3 Engine	88
8.4 Battery	89
8.5 Lighting	93
9 SAFE WORK PROCEDURES	97
9.1 General warnings	97
9.2 General warnings for truck mixers	99
9.3 Going up or down from the cab	101
9.4 Operator's seat adjustment	102
9.5 Fastening the seat belt	103
9.6 Inspections prior to starting-up	104
9.7 Starting and stopping the machine	106
9.8 Moving safely	110
9.9 Road travel	111
9.10 Momentary stop	112
9.11 Parking the vehicle	112
9.12 Driver's seat reversal	113
10 EMERGENCY PROCEDURES	115
10.1 Warnings if the vehicle should overturn	115
10.2 Start-up using auxiliary batteries	116
10.3 Machine towing	118
10.4 Deactivating the external parking brake manually	120
10.5 Deactivate transmission manually	121
11 MAINTENANCE	122
11.1 Maintenance warnings	122
11.2 Preliminary maintenance operations	126
11.3 Maintenance operations	127
11.4 Transmission maintenance	141
11.5 Wheel maintenance	142
11.6 Differential axle maintenance	144



11.7 Bolts tightening torque.....	145
11.8 Hydraulic fittings tightening torques.....	147
12 TECHNICAL SERVICE CENTRE	148
12.1 Spare parts supply.....	148
12.2 Assistance provided to the owner/ operator.....	148
12.3 Problems diagnostics	149
13 CLEANING	151
13.1 Cleaning the vehicle	151
13.2 Washing the windows	151
13.3 Cleaning the cab.....	152
13.4 Cleaning of the safety stickers	153
14 LIFTING, TRANSPORT AND STORAGE	154
14.1 Machine lifting.....	154
14.2 Transporting the vehicle	155
15 STORING THE VEHICLE.....	157
15.1 Long period of inactivity	157
15.2 Long period of inactivity	157
15.3 Restarting the vehicle	158
16 ELECTRICAL SYSTEM	159
16.1 Electrical system wiring diagram	159
16.2 Fuses	167
17 HYDRAULIC SYSTEM DIAGRAM	168
17.1 Hydraulic system L3500.....	168
17.2 Hydraulic system L4700.....	170
18 CONTROL AND MAINTENANCE LOGS	172
18.1 Type of logs	172
18.2 Instructions for compiling the logs.....	172
18.3 Periodic checks and recording mode (Italian only).....	175
18.4 Obligation and how to report to I.N.A.I.L. (National institute for insurance against accidents at work) (Italy only).....	176
19 NOTES.....	184

1 INTRODUCTION

1.1 Manual structure

This manual is an integral part of the official documentation of the vehicle and of the equipment. It must be carefully stored and be available to the managers, the users and personnel in charge of maintenance.

1.2 Purpose and content

This manual is an integral part of the official documentation and is aimed at supplying the Operator with all the information required concerning technical aspects, operation and safety during the entire lifespan of the vehicle or equipment.



- ATTENTION

This manual must be read carefully before using or performing maintenance on the vehicle.



- NOTE

If in doubt on the correct understanding of the instructions, contact the Manufacturer for clarifications.

1.3 Preservation

The instruction manual must be kept near the equipment available to the Users (in the cab or on the equipment where set up) inside a relative envelope, protected from liquids and anything that might make it illegible.

If the manual becomes creased and/or be, even partially, damaged or illegible or in case of loss of the manual, it must be replaced immediately by contacting the **DIECI TECHNICAL ASSISTANCE SERVICE**, giving the details of the manual found on the first page.

1.4 Addressees

This manual is addressed to the following persons:

- **Operator:** instructed person, trained with specific theoretical-practical course concerning use of the vehicle or equipment
- **Generic maintenance technician:** trained and educated person to perform routine maintenance interventions with basic mechanical, electrical and hydraulic knowledge
- **Specialised maintenance technician:** trained and educated person to perform routine and extraordinary maintenance interventions with in-depth and specific mechanical, electrical and hydraulic knowledge, normally sent or authorised by **DIECI S.R.L.** or the dealer.



- ATTENTION

The users must not carry out operations reserved for maintenance technicians or qualified technicians. The Manufacturer is not liable for damage deriving from the non-compliance with this prohibition.



1.4.1 Training

This manual gives the users all technical data on the vehicle or on the equipment, the presence and type of control and safety devices and the presence and meaning of the safety stickers and plates.

All vehicle or equipment users must have all necessary information, training and education in relation to the correct use conditions of the means and foreseeable anomalous risks.

The information, training and educating must be implemented upon introduction of new work equipment and for each work equipment available to users.



- NOTE

Ensure to respect the current laws and Standards in the selling country of the machine with regard to information, training and educating of personnel to use the vehicle and its equipment.

The employer must inform personnel on the following subjects on safe use:

- Risk of accident
- Individual safety devices and those of the machine, set up for operator safety
- General accident-prevention rules and/or foreseen by international directives
- Accident-prevention rules of Legislation of the Country where the vehicle is intended for use

Before starting to work the operator must know the vehicle features and must have fully read this Use and Maintenance Manual.

1.4.2 Training



- ATTENTION

The operator in charge of using the vehicle or equipment must have attended a suitable theoretical-practical course lasting as long as indicated by legal prescriptions in the Country where the vehicle or equipment is used.

Training must at least include the following subjects:

- Use and limits of the functioning and emergency controls of the equipment and of the vehicle on which the equipment is mounted.
- Knowledge and awareness of the Use and Maintenance Manual and of the control marks, of the instructions and of the warnings applied on the vehicle.
- Knowledge and understanding of the Standard on this equipment, including the educating aimed at recognising and avoiding potential dangers at work.
- Knowledge of the mechanical functioning of the vehicle sufficient for recognising a real or potential failure.
- Hints on constructive particulars of the vehicles and on static and dynamic stability concepts.
- Correct use of the vehicle procedures in safe conditions with regard to the work place and the load to be handled/lifted, capacity and guide notions.
- Knowledge and use of the PPE to be worn during use of the vehicle and of the equipment.
- Knowledge and execution of the routine maintenance to be carried out.

Training must be carried out under the supervision of a qualified person in an open area and free from obstacles. At the end of this practice, the trainee must be able to safely use the equipment, and the vehicle on which it is installed.

The operator must also be trained on the responsibility and authority of not using the vehicle in case of failure or presence of unsafe conditions, and request further information from the Manufacturer or authorised dealer.

1.4.3 Qualification

The vehicle and equipment are intended for professional use; their use must therefore be entrusted to qualified figures, in particular:

- Being of adult age
- Be physically and psychically suitable to carry out particularly difficult technical work
- Have been adequately trained on the use and maintenance of the vehicle and equipment
- Have been judged suitable by the employer to carry out the work entrusted to them
- Are able to understand and interpret the manual and the safety requirements
- Know the emergency procedures and their activation
- Have the ability of activating the specific type of vehicle or equipment
- Are familiar with the specific standards of the case
- Have understood the operational procedures defined by the Manufacturer of the vehicle or equipment



1.5 Terms, units of measurement and abbreviations used

	DECIMAL METRIC SYSTEM (SI)		ENGLISH IMPERIAL SYSTEM (IMP)	
	NAME	SYMBOL	NAME	SYMBOL
SURFACE				
	square meter	m ²	square foot	ft ²
ELECTRICITY				
	Ampere	A		
	Volt	V		
FORCE				
	kiloNewton	kN		
	Newton	N		
LENGTH FORCE				
	Newton/metres	N/m	pound/inch	lb/in
SURFACE FORCE - PRESSURE				
	kilopascal	kPa	Square pound/inch	psi
ROTATION FREQUENCY				
	Revolutions per minute	rpm		
LENGTH				
	kilometre	km	mile	mi
	metre	m	foot	ft
	centimetre	cm	inch	in
	millimetre	mm	inch	in
MASS				
	kilogram	kg	pound	lb
	ton	t	pound	lb
POWER				
	kilowatt	kW	horse power	HP
	Watt	W		
TEMPERATURE				
	Celsius degrees	°C	Fahrenheit degrees	°F
TORQUE				
	Newton metres	N m	pound feet	lb ft
			pound inch	lb in
SPEED				
	kilometres per hour	km/h	miles per hour	mph
	metres/second	m/s	feet/second	ft/s
VOLUME				
	cubic meter	m ³	cubic yard	yd ³
			cubic inch	in ³
	litre	l	UK gallon	UK gal

	DECIMAL METRIC SYSTEM (SI)		ENGLISH IMPERIAL SYSTEM (IMP)	
	NAME	SYMBOL	NAME	SYMBOL
TIME				
	hour	h	hour	h
	minute	min	minute	min
	second	s	second	s
VOLUME PER TIME				
	cubic metre per minute	m ³ /min	cubic foot per minute	ft ³ /min
	litre per minute	l/min	UK gallon per minute	UK gal ³ /min
SOUND POWER AND ACOUSTIC PRESSURE				
	decibel	dB		

1.6 Used symbols









1.6.1 Symbols key in manual

Carefully read the safety regulations given and follow all recommended precautions in order to avoid potential risks and safeguard your health and safety.

The symbols listed below are inserted to highlight situations which **DIECI S.R.L.** considers particularly important.

However, this manual must be read completely and understood and must be kept inside the vehicle, covered and protected, available to all vehicle users.



If in doubt, contact the nearest agent or dealer.

SYMBOL	MEANING	COMMENT
	DANGER	Indicates an important safety message. When you see this symbol, carefully read the information that follows and inform other operators in order to prevent risks and hazards.
	SPECIFIC DANGER	Indicates a specific danger with risk, even serious, for the user. (Electrical danger provided as example)
	ATTENTION	Indicates a warning addressed to avoid a potentially dangerous situation
	NOTE	Indicates a WARNING or a note on key functions or on useful information.
	PROHIBITION	Indicates strictly prohibited actions or things that are dangerous to personnel.
	CONSULTATION	Indicates reference to other paragraphs or manuals.
	MAINTENANCE	Indicates a maintenance operation that must be carried out by a General or specialised maintenance technician.
	OPTIONAL	Indicates possible installation or presence of an optional available at DIECI S.R.L. distributors.

1.6.2 *Dumper symbols legend*

The symbols listed below have been used to describe actions and functions of the machine and of its components, for an easier and immediate recognition during the working phases.

If in doubt, contact your agent or dealer.

SYMBOL	MEANING
	Dump body lifting
	Dump body lowering



2 GUARANTEE

The guarantee is applied to all manufacturing and material defects, duly certified, and is exclusively limited to the repair or replacement of parts that, at the discretion of the Company, are acknowledged as faulty, as well as the labour necessary for such repairs or replacements, on the basis of guarantee times established by the Company.

All interventions carried out during the guarantee period must be carried out by personnel authorised by the Company (otherwise, the right to guarantee cover is declined).

2.1 Exclusions from the guarantee

Damage to the vehicle caused by the following is not included in the Guarantee:

- Operator errors
- Failure to perform the maintenance stipulated in this Manual
- Faults and/or breaks not attributable to its malfunction
- Tampering with equipment
- Normal operating wear
- Deterioration of the parts that have a purely aesthetic function
- Repairs by unauthorised centres or persons
- Product use with methods that do not comply with the warnings provided in this Use and Maintenance Manual.
- Damage caused by the unsuitability of the environment in which the equipment works and phenomena that are not caused by its normal operation
- Consumable components subject to wear: clutch, belts, brake pads, slide blocks, rollers, oil and liquids, filters, etc.
- The electrical components and systems.
- Damage caused by: climatic agents, natural disasters, vandalism, etc.
- Any other malfunction not due to a certified defect resulting from an original fault or that does not fall under the responsibility of **DIECI S.R.L.**

The following parts are also excluded from this guarantee but are covered by the guarantee of the relevant Manufacturers:

- Diesel engine
- Axles and reduction gears
- Hydraulic pumps and engines
- Tyres

DIECI S.R.L. shall handle the application of the aforementioned guarantees.

2.2 Guarantee: duration

DIECI S.R.L. guarantees its products for 12 months from the date of delivery to the Customer or Dealer/Distributor.

If the vehicle is stored for long periods by the Dealer/Distributor at the time of sale to the customer, the Service Centre will reserve the right to verify guarantee activation.

2.3 Guarantee: validity

The guarantee is valid from the date the vehicle is shipped from the factory (sales to Distributors or Dealers). When delivery is handled by the Distributor or Dealer, **DIECI S.R.L.** reserves the right to verify that the guarantee start date corresponds to the shipping or delivery date on the transport document of the product being guaranteed, and/or to the invoice date, and can request original copies of these documents.

2.4 Guarantee: activation

The guarantee is automatically valid from the date the vehicle leaves the factory (sale to Distributors or Dealers).

2.5 Guarantee: validity

2.5.1 *Guarantee in countries with assistance centres*

The guarantee covers the replacement or repair of faulty parts proven defective as a result of the material used, its manufacturing or assembly.

DIECI S.R.L. reserves the sole right to authorise the repair or replacement of faulty parts.

DIECI S.R.L. shall resolve the anomaly through the means and methods it deems most appropriate

DIECI S.R.L. is responsible for:

- The materials used
- Labour
- Travel expenses

The Customer is responsible for:

- Packing and shipping costs for replacement parts
- All other expenses not listed under those for which **DIECI S.R.L.** is liable

2.5.2 *Guarantee in countries with NO assistance centres*

Refers exclusively to the free supply, ex works by **DIECI S.R.L.**, of parts no longer usable due to faulty original material, manufacturing and/or assembly.

2.5.3 *Examining replaced faulty parts*

Before honouring the guarantee, **DIECI S.R.L.** may ask for the faulty parts replaced during the repairs to be returned at DIECI's expense.

2.5.4 *Additional guarantee for repairs and replacement parts*

Repairs made under guarantee or not, and parts replaced during repair work, are guaranteed for 3 months from the date of repair or installation, even if the original guarantee has expired.

2.5.5 *Intervention campaigns for faulty products*

The replacement procedures of parts acknowledged to be faulty will be agreed upon by **DIECI S.R.L.** and its distributors/dealers/ authorised workshops.

These intervention campaigns can be followed directly by **DIECI S.R.L.** suppliers, who are responsible for supplying the components to be replaced (interventions authorised by **DIECI S.R.L.**).

The above interventions will be preceded by written communication from **DIECI S.R.L.** to its purchasers.

Only **DIECI S.R.L.** can decide the intervention method (repair, replacement or modification).



2.6 Guarantee: intervention request

2.6.1 *Guarantee: claim*

The claim of the faulty part must be made by the Customer, Dealer, Distributor or Authorised workshop and must be sent directly to **DIECI S.R.L.** Customer Service within 8 days from when it is noted.

The claim must include a clear description of the defect and precise references to the vehicle (type, model, and serial number). This information can be found on the vehicle in the places indicated in the USE AND MAINTENANCE MANUAL.

2.6.2 *Obligation of vehicle downtime*

If there is a risk that the defect may jeopardise safety and accident prevention or may cause further damage, the vehicle must not be used until it has been repaired and tested.

Every modification made to the vehicle requires a new verification of conformity with the 2006/42/EC Machinery Directive. This procedure is also valid in the case of repairs with non-original spare parts.

In the event of any dispute, exclusive jurisdiction will be held by the Court of Reggio Emilia - ITALY.

2.7 Non-activation, failure to honour, termination

2.7.1 *non-acknowledgement*

The guarantee is not honoured:

- If the defect is not reported as described and within the established time limit.
- If the customer does not comply with **DIECI S.R.L.'S** request to return the faulty parts replaced during the repairs.
- If the customer has not complied with the obligation to stop using the vehicle after making a claim, limited to damages caused by noncompliance.

2.7.2 *Guarantee: termination*

The guarantee is terminated:

- If the buyer does not fulfil contractual payment obligations.
- If damage has been caused by carelessness, negligence, or by use of the vehicle for purposes not in compliance with specifications provided in the use and maintenance manual (incorrect manoeuvres, overloading, use of incorrect fuel, poor maintenance, disregard for warning indicator instruments etc.)
- If the defect is a result of applications, equipment, modifications or repairs not authorised by **DIECI S.R.L.** or carried out using poor quality parts. (For this reason, we recommend always using original spare parts).



Refer to the "MAINTENANCE" paragraph for information regarding recommended routine maintenance.

2.8 Final terms

In none of the cases regarding non-activation of the guarantee, it not being honoured or being terminated, the buyer cannot demand cancellation of the contract, or compensation, or an extension of the guarantee.

Any guarantee conditions other than those listed above must be agreed upon in writing and signed by both parties.

Unless agreed upon in writing by both parties; **DIECI S.R.L.** does not pay compensation for any type of claim caused by vehicle downtime, such as:

- Replaced or rented vehicles
- Labour
- Loss of profit



3 SAFETY REGULATIONS

3.1 General warnings

The instructions for use, maintenance and repair described in this handbook must be followed if the vehicle is to be considered as being operated in accordance with the manufacturer's intended uses.



- FORBIDDEN

THE MACHINERY AND EQUIPMENT CANNOT BE MODIFIED WITHOUT THE MANUFACTURER'S AUTHORISATION.

To guarantee your safety and that of others, do not modify the structure or adjust the various accessory components of the vehicle or equipment. The same holds true for the deactivation or modification of safety devices present.



- ATTENTION

Any modification made to the vehicle or accessories will absolve DIECI S.R.L. from all liability for damage or injury resulting from such modification.



- ATTENTION

Every vehicle or accessory must be used, assisted or repaired only by persons that have received training in advance on the vehicle and on its safety regulations, in addition to being authorised to use the vehicle or accessory itself.



- ATTENTION

The user must always observe the general safety regulations as well as those for accident prevention, such as traffic rules if the vehicle is used on public roads (according to the regulations in force in the country of use).



- FORBIDDEN

USE OF THE VEHICLE OR OF THE ACCESSORIES DIFFERENT TO THAT DESCRIBED IN THIS MANUAL IS PROHIBITED.



- FORBIDDEN

THE VEHICLES OR ACCESSORIES IN QUESTION ARE NOT SET-UP FOR USE IN ENVIRONMENTS OR SITES EXPOSED TO THE PRESENCE OF EXPLOSIVE GASES, THUS PROHIBITING USE IN THESE PLACES.

To operate in closed spaces, the Manufacturer must be contacted so that the necessary modifications can be made to the vehicle.



- FORBIDDEN

All functions and procedures concerning the operation and mounting of the vehicle or its equipment that are not described in this manual are strictly FORBIDDEN.



- DANGER

DO NOT USE THE VEHICLE OR THE ACCESSORIES IF YOU ARE UNDER THE EFFECT OF ALCOHOL, DRUGS OR IF YOU HAVE TAKEN MEDICINES THAT MAY MAKE YOU DROWSY OR MAY ALTER YOUR REFLEX AND REACTION TIME.



- ATTENTION

Read all of the safety stickers on the vehicle and observe all regulations printed on these stickers before starting up, running or refuelling the vehicle or before carrying out maintenance work. Immediately replace damaged, lost or illegible decals. Clean the stickers if they are covered by dirt, cement or other deposits.



- NOTE

DIECI S.R.L. is not liable for damage caused by negligent use of this vehicle or the accessory even if said damage is not a result of intentional improper use. Everything possible has been done during the design and construction phases of vehicles and accessories to make your job as safe as possible. Due caution, however, is indispensable and there is no better rule to prevent accidents.

3.2 Safety indications



- ATTENTION

Carefully observe and follow all safety signals on the vehicle and on the accessories and read all safety messages in this manual.

- The safety signals must be installed, maintained and replaced when necessary.
- If a safety signal or this manual is damaged or missing, order a replacement from the **DIECI S.R.L.** dealer in the same manner as spare parts (make sure you provide the model and serial number of the vehicle or accessory when placing the order).
- Learn how to correctly and safely operate the vehicle and the accessories and their relative controls.
- Allow only trained, qualified and authorised personnel to operate the machine and installed accessories.
- Keep the vehicle and accessories in appropriate working conditions.
- Unauthorised modifications to the vehicle or accessories can jeopardise the functioning and/or safety and influence their life-span.
- The safety messages in this SAFETY REGULATIONS chapter illustrate the basic safety procedures of the vehicles.
- In case of doubt, contact the manager before proceeding to operate or carry out maintenance work on the vehicle or on the accessories.

3.3 Personal protective devices

3.3.1 Protective clothing

In some cases, when working in particularly uncomfortable environments, adequate clothing or equipment must be worn.

It is necessary to have:

- Protective helmet
- Accident-prevention shoes
- Protective goggles or protective face mask
- Protective gloves
- Protective headwear against noise
- Reflective clothing
- Waterproof clothing
- Breathing apparatus or filtering mask

Before operating the vehicle, it is the personnel's responsibility, to ask the safety manager about the possible risks of the work and the accident prevention clothing that must be worn.

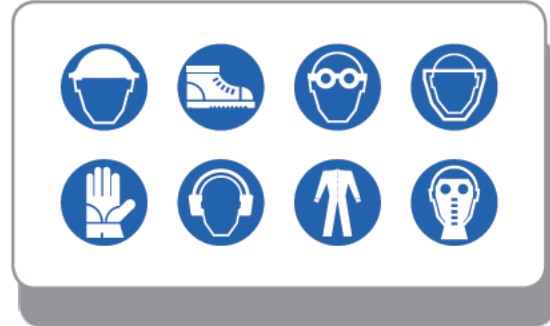

- ATTENTION

The Personal Protective Equipment used by the operators can have different characteristics, depending on the type of construction site and risks present in the work place.

Always use PPE that is appropriate for the type of work to be performed.



- ATTENTION

Pay attention to moving parts to avoid danger of crushing or dragging of the lower and upper limbs. Avoid wearing jewellery or pendants that might be trapped in moving parts. Long hair must be tied back to avoid it being caught in moving parts.



- FORBIDDEN

Do not wear loose clothing, chains, belts or other accessories that may be caught in the control levers or in other parts of the vehicle.



- FORBIDDEN

Headphones for listening to the radio or music should not be worn while using the vehicle.

**- ATTENTION**

Accident prevention equipment must always be whole and in good condition. Damaged clothing cannot ensure adequate protection. Do not wear damaged clothing; always replace damaged or torn clothing before operating the vehicle.

3.3.2 *Protect yourself against noise*

Prolonged exposure to loud noise can damage your hearing or may cause hearing loss.

**- ATTENTION**

Always wear anti-noise earmuffs or earplugs to protect yourself from excessive and irritating noises.

3.3.3 *Protections against the falling of objects from a height*

The vehicle is equipped with a protective cab against falling objecting (FOPS).

**- ATTENTION**

Use of a safety helmet is required if there is a risk of falling objects.

3.3.4 *Protect yourself from flying fragments***- ATTENTION**

During operation in certain conditions, particles of material may be ejected. In such conditions, it is a good idea to wear protective goggles and clear the area of those people not in possession of such goggles.



3.4 Preparing for accidents

- Always be prepared in the event of a fire or an accident.
- Keep a fire extinguisher and first aid kit at hand. (Not supplied by the manufacturer, "optional accessories").
- Carry out periodic inspections to ensure that the first aid kit contains all necessary items; replenish content if necessary.
- To properly use the extinguisher, carefully read the instructions located on the extinguisher.
- Carry out periodic inspections and maintenance (six monthly) to ensure that the extinguisher is ready for use at any given moment.
- Create priority procedures to deal with fires or accidents.
- Keep emergency telephone numbers (doctors, ambulance, hospital and fire brigade) clearly visible and near the telephone.
- Adequately trained and educated personnel must be present for managing emergencies with adequate theoretical-practical course carried out on site.

Below are some First Aid procedures that can be activated in case of accident following use of the vehicle or equipment object of this use and maintenance manual.

These procedures may be useful in an emergency for the users or other operators present near-by, during use and various life-phases of the vehicle or of the equipment (transport, installation, use, maintenance, adjustment, etc.).

3.4.1 *First Aider Tasks*

1. Activate first aid (emergency call).
2. Evaluate the victim and, if necessary, support vital functions.
3. Stop an external haemorrhage.
4. Protect wounds and burns.
5. Protect the victim against further damages.
6. Do not perform unnecessary or damaging actions, which give beverages, move the victim, reduce dislocations and/or fractures, etc.

3.4.2 *Emergency call*

Good first aid intervention also depends on the timely arrival of rescuers (Italian emergency medical support) to the place of the emergency.

This is why the first aider in charge of calling the emergency must precisely indicate:

- Address of where the accident or illness took place.
- Number of injured or ill parties.
- The possible cause of the event.
- The state of the vital functions of the injured party, specifying whether the same is conscious or not and breathes normally or not.

At the end of the call it is recommended to:

- Give own details, indicating a telephone number where to be contacted.
- Wait for the rescuers outside the company (for example, near the reception).

3.4.3 Traumas

Distortions, dislocations and fractures:

Immobilise the joints in the position after the trauma, using bandages or storage, supporting the analgesic position of the injured party without attempting dangerous manoeuvres. Apply the cold (with bag of ice or other systems). In case of exposed fracture, cover the wound using a sterile gauze pad, after having pressed at a distance on the specific points the relative haemorrhage.

Contusions, crushing:

In case of contusions and/or crushing of ends of the upper and lower limbs (fingers, hand, feet, etc.) it is advised to immediately place the limb underneath running water (cold) and apply ice. Also check for wounds and/or cuts in the hit area and, if necessary, disinfect with the due precautions.

3.4.4 Haemorrhages

It is necessary to press the fingers on the haemorrhage point with sterile gauze pad, lifting the limb and eventually compress upstream of the haemorrhage with tourniquet.

Treating superficial wounds:

Carefully expose and clean the wound, disinfect it with physiological solution, medicate it covering it with sterile gauze pads. Bandage avoiding excessive tightening to allow good circulation.

Treating deep wounds:

It is a priority to protect yourself against the risk of infection using gloves and splash shield; pad the haemorrhage by direct pressure or using other pressure points until it stops or the arrival of the ambulance. Call the medical emergency number, informing them that you are padding an arterial haemorrhage.

Treat the wound only after the haemorrhage is under control.



- NOTE

Do not use cotton wool, methylated spirit, antibiotic powder to disinfect the wound.

3.5 Preventing fires and accidents

3.5.1 Risks of fires



- FORBIDDEN ACTION

It is forbidden to smoke or use naked flames during use of the vehicle or any maintenance operation.



- DANGER

Do not operate the vehicle without the following safety conditions:



- DANGER

1 - Fuel, oil and lubricant leaks can trigger fires and cause serious injuries.

- Ensure that there are no flammable liquids leaking.
- To avoid oil or diesel leaks, make sure that there are no loose or missing clamps, no twisted tubes and no tubes that rub up against each other.
- Do not bend any tubes/pipes under pressure.
- Never install damaged tubes.
- Do not weld tubes or pipes containing inflammable liquids.
- Do not use a torch head to cut tubes or pipes containing inflammable liquids.



- DANGER

2- Short circuits may cause fires.

- Ensure that there are no short circuits.
- Clean and interrupt all electrical connections.
- Before every work shift, make sure that there are no loose, twisted, hardened or damaged electric cables.



- DANGER

3 - Fuel, oil, grease, waste, deposits or accumulated dust or other components can cause a fire.

- Remove inflammable materials.
- Prevent fires by inspecting and cleaning the vehicle at every shift, by immediately removing inflammable components.
- Check the ignition switch: in the event of fire, failure to switch off the engine will obstruct the work of the Fire Brigade.
- Do not use mazut, petrol or inflammable liquids to clean parts of the vehicle. Only use non-flammable detergents.



- DANGER

4 - Safely handle dangerous liquids.

- Handle fuel with care, it is easily inflammable. If fuel is ignited, there may be an explosion and/or a fire.
- Do not refuel the vehicle while smoking and in presence of naked flames or sparks.
- Always stop the engine before refuelling the vehicle.
- Fill up the tank outside.
- All fuels, most lubricants and some anti-freezes are inflammable.
- Preserve the flammable fluids away from fire hazards.
- Do not burn or drill pressurised containers.
- Do not keep cloths soaked with lubricant; they may cause fires and spontaneous combustions.

3.5.2 Risks of inhaling gas



- DANGER

Exhaust engine gases are toxic and can cause damages to your health.

- If necessary to work in closed ambients, ensure it is sufficiently ventilated and equip the vehicle with special purifiers.

3.5.3 Risks of batteries exploding



- DANGER

The gas of the batteries may explode.

- Keep any sparks, open flames or lit cigarettes away from the upper part of the battery.
- Never place a metal object between the terminals to check the battery charge. Use a voltmeter or a densimeter.
- Do not create sparks in the battery connection during recharging phases or starting the engine with auxiliary battery.
- Do not charge the batteries if they are extremely cold, extremely hot or damages as they might explode.
- Heat the batteries up to 16°C.
- The electrolyte in the batteries is an extremely corrosive acid.
- Should the battery explode, the electrolyte may be sprayed in the eyes with the possibility of causing blindness.
- Ensure to be wearing protective goggles when carrying out maintenance on the batteries.
- Do not overturn or tilt the battery as acid could come out.

3.5.4 Residue risks



- KEEP AWAY FROM MOVING PARTS

Damage may be caused by entanglement in moving parts.



- AVOID BURNS

- Jets of hot fluids:

After operation, the engine cooling liquid is hot and under pressure. Contact with hot water or steam may cause serious burns.

Avoid possible injury caused by hot water jets. Do not remove the radiator cap until the engine has cooled down. To open it, unscrew the cap as far as possible. Before removing the cap, release all of the pressure.

- Hot surfaces and fluids:

The engine, reduction gears and hydraulic system oil heat up during vehicle use. The engine, rigid and flexible piping and other components heat up.

Wait until all parts cool down before beginning maintenance or repair work.



- CAUTION WITH PRESSURISED FLUIDS

Fluids such as fuel or hydraulic oil under pressure can penetrate the skin and eyes causing serious injuries.

Avoid these dangers while repairing or carrying out maintenance on the vehicle, discharging the pressures (using the hydraulic levers of the distributors) before disconnecting or repairing pipes and hydraulic parts.

Before restarting the engine, ensure that all connections have been correctly tightened.

Use a piece of cardboard to check for any leaks; make sure your hands and body are adequately protected against pressurised fluids. Wear a face mask or accident-prevention goggles to protect your eyes.

Should there be an accident, seek medical attention immediately. Any fluids that penetrate the skin must be removed surgically within a few hours to avoid infections.



- ELECTROCUTION

All maintenance and/or adjustment interventions on powered parts must be carried out only and exclusively by qualified and adequately trained personnel.



- RISK OF SLIPPING

During on-site operations, the areas around the equipment may have debris and liquid (oil, water, etc.) that might make the floor slippery. Pay the utmost attention.



- RISK OF FALLING, TRIPPING

Pay the utmost attention when climbing in and out from the vehicle.



- CRUSHING OF HANDS AND FEET

The presence of moving parts during functioning can cause risks for the ground operators. During vehicle manoeuvres, carefully check no unauthorised person is within the required moving area.

3.5.5 *Contact with dangerous substances*

- Wear the necessary protective clothing.
- Refer to the safety data sheet of the product used and take appropriate precautionary measures when using the product.
- Avoid contact with skin and eyes.
 - In case of contact with eyes: rinse them thoroughly with plenty of water for a few minutes keeping the eyelids open and consult a doctor.
 - Should any fluid come into contact with skin, wash the area carefully, remove contaminated clothing, and when skin is dry, apply moisturising cream. Consult a doctor if necessary.
 - In the event of inhalation, move away from the contaminated area and go to a well-ventilated location. Consult a doctor in the event of respiratory problems.
 - If swallowed: immediately contact a doctor, showing the label or container. Do not induce vomiting to avoid the risk of inhalation via respiratory passageways.

3.6 Storing dangerous liquids



- NOTE

Handle fuel with care, it is easily inflammable. If fuel is ignited, there may be an explosion and/or a fire.



- DANGER FLAMMABLE MATERIAL

All fuels, most lubricants and some anti-freezes are inflammable.



- DANGER

All fluids must be kept out of the reach of children and incompetent persons.



- IT IS FORBIDDEN TO SMOKE AND HAVE OPEN FLAMES

It is forbidden to smoke or to use naked flames near fuels.



- FORBIDDEN

Different types of substances must not be stored or mixed together.



- ATTENTION

All chemical products are generally very noxious to our health, avoid contact with the skin and eyes by wearing suitable protective clothing. Do not ingest.



- ATTENTION

Comply with the following precautions to store dangerous liquids:

- All inflammable fluids must be stored in special containers, and the content of the containers must be clearly indicated. Containers must be tightly sealed.
- Store inflammable fluids in well-ventilated locations, far away from heat sources, sparks and open flames.
- Keep containers closed and covered. Other substances (e.g. foodstuffs) must not be present in this location.
- Always fill up the tank outside.
- Be careful of fumes and steam which may be formed by chemical products. Avoid inhalation.
- Do not breathe in fuel fumes.
- Ensure that these chemical products do not spill or flow into the ground, sewers or puddles. If necessary, inform the competent local authorities.
- In the event of a fire, use carbon dioxide, dry chemical powder, foam, nebulised water, sand, earth. Use jets of water to cool down surfaces exposed to the fire.
- Verify that there are no leaks of inflammable liquid (fuel, oil, grease, general lubrication leaks) in the storage containers.



Refer to the safety data sheet of the product for additional precautions and warnings that are to be adopted.

3.7 Warnings for safe working

3.7.1 Ensuring the vehicle is clean

- Clean the windows, lights and rear-view mirrors.
- Clean dirt and waste away from the engine, joints and radiator
- Make sure the cab steps and the handle are clean and dry.
- Clean all safety stickers and manoeuvring instructions. Replace any stickers that are illegible or missing.



For the cleaning procedures, refer to the "CLEANING" chapter.



- FORBIDDEN

If the vehicle or equipment is not in perfect working order its operation is strictly prohibited.

3.7.2 Checking for damage

- Make sure there are no damaged or missing parts
- Make sure all articulated pins are properly fastened.
- Make sure there are no signs of possible cracks or flaws or other damage to the windows.
- Make sure there are no oil, fuel or cooling liquid leaks underneath the vehicle.
- Make sure the wheel bolts are properly tightened.



- FORBIDDEN

If the vehicle or equipment is not in perfect working order its operation is strictly prohibited.

3.7.3 Start working with the vehicle

Regardless of their level of driving experience, operators must familiarise themselves with the position and function of all controls and instruments before operating the machine.

- Before using the vehicle, check location of personnel.
- While the vehicle is running, always keep light signals on. These serves to warn people that the vehicle is about to move.
- When working in a congested area, have another person present for signalling.
- When manoeuvring the vehicle, pay attention to bulky vehicle parts. There are parts that jut out from the cab.
- Never use controls for purposes different than those for which they were created for; e.g. to climb on or off from the vehicle or hang clothing, etc...
- Only use the vehicle from the driver's position.
- The vehicle may move suddenly if started up without following the correct procedure, thus, creating the risk of personal injury.
- Start up the engine from the driver's seat only.
- Never start the engine by causing a short circuit between the terminals on the starter.
- Before starting the engine, make sure all control levers are in a neutral position.



3.7.4 *Passengers transportation*

Only the operator must be on board the vehicle, passengers are not admitted.

Passengers may obstruct the operator's view, causing an unsafe operation of the vehicle.



- FORBIDDEN

Carrying people on or lifting people up with the vehicle is strictly prohibited unless the vehicle is equipped with an elevation work platform and has a special certificate of conformity regarding the transport of people.



- FORBIDDEN

It is strictly forbidden to transport persons inside the basket while the vehicle is moving even in the presence of elevation work platform and certificate of conformity. It is compulsory to use the basket only with the parking brake engaged and the outriggers lowered (if present).

3.7.5 Electrical system protection



- ATTENTION

A burnt fuse must be replaced with another fuse of the same type, amperage and class. Other types of interventions are not allowed, even if temporary.

Do not connect or remove terminals, fuses, or connectors when the vehicle is switched on or electrically powered.



- ATTENTION

Any intervention on the electric plant must take place with the vehicle not powered electrically. Restore the power supply only after the intervention has been concluded. Remount the lids and protections.

- Use the battery isolator to cut off power to the vehicle.
- Cut off power by means of the battery cut-off even before replacing the vehicle battery.
- In the event that a connector is damaged or is no longer inserted in its housing, replace it immediately in order to avoid short circuits or sparks.



- ATTENTION

Damaged, pinched or burnt cables must be replaced immediately even if damage is only to the sheathing or outer insulation.

- Never carry out or interrupt any connection on the load circuit, including connections on the battery, with the engine running.
- Never ground (earth) short circuit any charging component.
- Do not use an auxiliary battery with nominal voltage exceeding 12 volt.
- Make sure the polarity is correct when putting in the battery or when using an auxiliary battery when starting the vehicle with cables. Follow the use and maintenance instructions of the manual when starting up the vehicle with cables.
- Always disconnect the negative cable from the battery before performing arc welding on the vehicle or on any connected attachment.
- Position the welding machine's ground terminal as close as possible to the area to be welded.



- ATTENTION

If welding is to be carried out near an electrical module, this module must be removed from the vehicle. Only qualified and authorised personnel should carry out this operation.

- Do not allow welding machine cables go above, near or cross over any electrical cable or electronic component while welding is in progress.

3.7.6 Signals to multiple vehicles







When working requiring more vehicles, give signals normally known to all employed personnel. Designate one person to signal and coordinate the work zone.







- ATTENTION

Before operating make sure that:

- The user and signaller are aware of the hand signals to be able to interact between them
- That everyone follows the directions given by the person in charge of signalling.
- The signaller must be easily identified by the user of the vehicle.
- The signaller must wear or hold one or more adequate recognition elements, like: jacket, helmet, sleeves, bracelets, signal paddles.
- The recognition elements must be bright coloured, preferably one, and reserved exclusively for the signaller.

Movement	Meaning	Description
	Start - Attention - Control socket	The two arms are open horizontally, the palm of the hands forward
	Stop - Interruption - End of motion	The right arm is stretched upwards, with palm of right hand forward
	Danger - Stop - Emergency stop	Both arms stretched upwards
	End of operations	The two hands are joint at height of chest
	Lift	The right arm, stretched upwards, with palm of right hand forward, makes a circle
	Lower	The right arm, stretched downwards, with palm of the hand towards the body, makes a circle

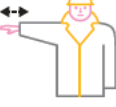
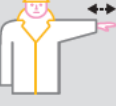
Movement	Meaning	Description
	Vertical distance	The hands, one on top of the other, indicate the distance
	Horizontal distance	The hands, one next to the other, indicate the distance
	Forward	Both arms are folded, the palms of the hands backwards and the forearms make slow movements towards the body
	Move back	Both arms are folded, the palms of the hands forward and the forearms make slow movements away from the body
	To the right compared to operator	The right arm, stretched horizontally, with palm of right hand downwards, slowly makes small movements towards
	To the left compared to operator	The left arm, stretched horizontally, with palm of left hand downwards, slowly makes small movements towards
	Quick motion	The conventional signals used to indicate movements are quickly made
	Slow motion	The conventional signals used to indicate movements are made very slowly



3.7.7 Working with the danger of masses and objects falling



- OBJECTS FALLING

When working in areas where there is a risk of falling, bouncing or interference from objects capable of hitting the operator or entering the cab:

- Mount suitable safety panels to protect the operator.
- Always close windows.
- Always ensure that other operators near-by are at a safe distance and cannot be hit by bouncing or falling objects.
- Pay careful attention to crumbling walls, landslides, falling material or objects from the installed equipment, that may hit the cab, the protective structure or windows, causing damages to the vehicle and to the operator.
- Never carry out work operations under an overhang; this could give way and fall onto the vehicle.
- Do not excessively weigh down or fill the installed equipment or transport loads that may come out or fall on the ground.



- ATTENTION

Use of a safety helmet is required if there is a risk of falling objects.

3.7.8 Work near electrical lines



- HIGH VOLTAGE

Before working near overhead electrical lines, check that the safety distance is sufficient, in compliance with the current Standard in the country of use. In any case, never work near electrical lines at distances shorter than those in the table below or at the minimum distances indicated by the Standards in force in the country of use of the vehicle.

Damp ground may increase the risk of electrocution.

Operating or parking the vehicle too close to electrical cables leads to increased risk of being struck by lightning or being seriously injured.

Designate someone on the ground to signal when too close to power lines.

Do not allow anyone near the vehicle when working in the vicinity of power lines. To prepare for any possible emergency situation, wear rubber shoes and gloves, cover the seat with a rubber piece of fabric and take care not to touch the chassis with any unprotected body parts.



- DANGER

Should the vehicle collide with an electrical cable, the user, to avoid electrocution, must remain inside the driver's cab until certain that the electrical power supply has been properly disconnected.



- DANGER

If operating close to overhead electrical lines, check the safety distance in the table below, reported in Legislative Decree 81/08 Enclosure IX. The table is valid if the vehicle is used on Italian territory. However, refer to the Standards in force in the country of use of the vehicle.

At (kV)	Distance
≤ 1	3 m (9.84 ft)
$1 < U_n \leq 30$	3.5 m (11.48 ft)
$30 < U_n \leq 132$	5 m (16.40 ft)
> 132	7 m (22.96 ft)

3.7.9 Working under the snow



- SNOW OR ICE

Snow can hide obstacles and objects, and cover holes, dug-out areas and ditches, therefore, proceed with caution.



- FORBIDDEN

Operation of the vehicle if the quantity of snow does not allow for clear distinction of obstacles and possible dangers along the path is strictly prohibited.

- Take care when clearing snow and do not venture off the main road; that which is hidden at the sides of the road may cause vehicle overturning or damage to various components.
- Surfaces covered by snow or ice are extremely dangerous. Operate with caution, reducing vehicle speed as much as possible and engaging levers slowly.
- Operate with caution. If the vehicle should sink into the snow, it may overturn or remain buried. Do not venture from the road and avoid remaining entrapped or buried under heaps of snow.
- Extra care should be taken, when working on icy terrain. Should the temperature rise, the ice could melt and the ground could become slippery.
- Use caution in the presence of electrical cables, ditches, or freshly excavated or worked ground.
- Make sure not to cause risk to others in the area when backing up the vehicle.
- Always check the space around the vehicle before carrying out any manoeuvres.



- NOTE

If working the vehicle at low temperatures (-10°C), empty and refill the tank using lubricants, fuel or cooling liquids suitable for such temperatures.



There are accessories that can be used to facilitate working with ice or snow, contact your dealer or agent.

3.7.10 Working with scarce lighting



- ATTENTION

The standard illumination of the vehicle is not suitable in working conditions with poor visibility or for use at night. The vehicle can only be used with sufficient lighting in the work some



There are several ways to improve visibility in conditions of poor lighting. Contact your local DIECI S.R.L. dealer.



3.7.11 Working in closed areas or dangerous atmospheres



- FORBIDDEN

It is FORBIDDEN to use the machine in:

- Suitably ventilated closed spaces, that are nevertheless not compatible for the use of equipment with running endothermic motors.
- Spaces with dangerous or explosive atmospheres.
- Protected environments such as refineries.



- ATTENTION

The vehicle can only be used in a tunnel if it has been declared suitable for these environments. The vehicle must be appropriately modified and certified to work in environments with an explosive atmosphere.

4 GENERAL INFORMATION

4.1 General

The purpose of this publication is to provide safe and effective instructions to the Operator on use and maintenance of:

Dumper DP 4200

Dumper DP 7000

This machine has been designed and built as a self-propelled machine with operator's seat, wheels, designed for use on paved or natural ground and on uneven ground.



- CAUTION

Any other use is considered contrary to the intended use by DIECI which, therefore, can not be responsible for damage to objects and the machine itself, or injury to persons that might derive from misuse.

For other controls, or complaints to agencies, refer to the applicable local legislation in the country of use of the machine.



4.2 Identification of the machine

Machine model (Fig. 1-D00-00)
Year
Serial number of the chassis (Fig. 2-D00-00)
Serial number of the engine (Fig. 3-D00-00)
Serial number of the cab (Fig. 4-D00-00)
Owner / Operator
Address of the Dealer or Agent
Delivery date
Warranty expiry date

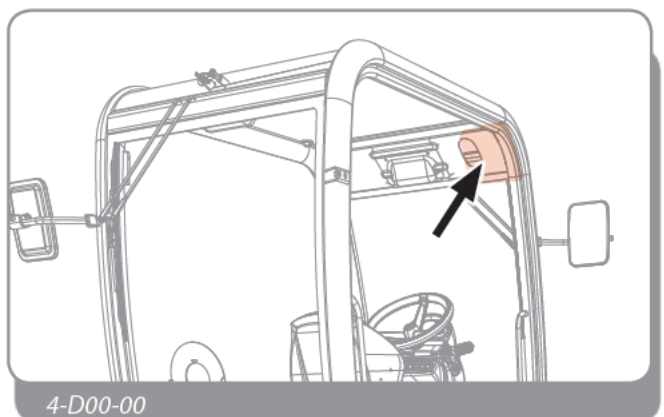
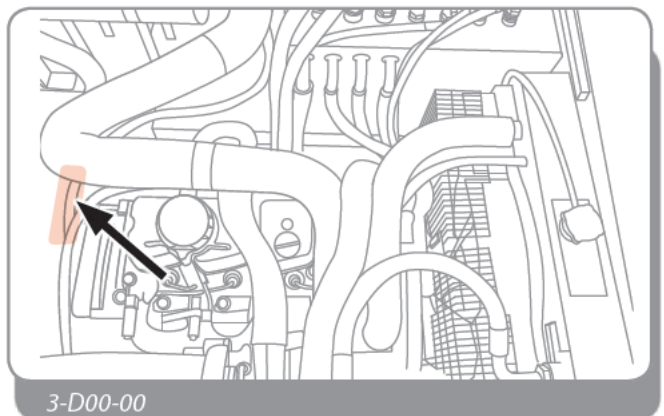
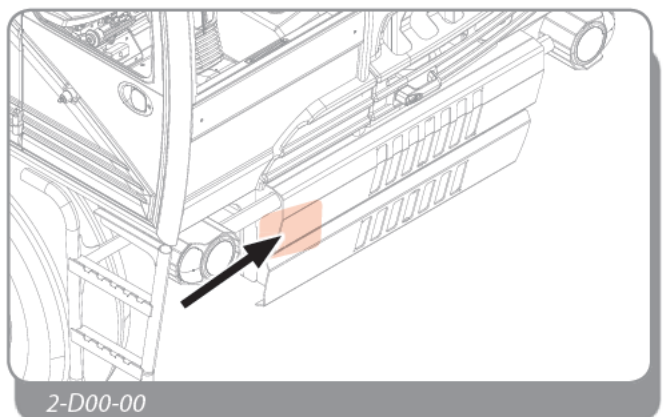

Equipment code	Serial number	Year
.....
.....
.....

4.3 Intended use

The machine described in this document must definitely be used only for the purposes set out in this Use and Maintenance manual.

Adherence to and strict compliance with the terms of use, repair and maintenance, as specified by the Manufacturer, are essential elements covered by the intended use.



- CAUTION

The machine must be used ONLY by trained and qualified staff who is aware of the information contained in this Manual.

4.4 Contraindications for use

The machine must NOT be used:

- For recipients other than those listed in the "Recipients" chapter
- For uses other than those mentioned in this manual
- In environmental conditions other than those listed in chapter "Environmental Conditions"
- In use on the road, use the machine only if in possession of a valid driver's license in accordance with the regulations in force in the country of use
- Do not use hydraulic moving parts of the machine to lift people



- WARNING

For any other use of the machine, other than those mentioned above, the Manufacturer will reserve the right to revise the terms of the warranty.

4.5 Declaration of first test

Manufacturer's declaration of first test

DIECI S.R.L. declares that each machine and equipment manufactured at its plants, before placing on the market, have been subjected to static and dynamic tests designed to verify proper operation and compliance with EU directives to which it is subject.

At the conclusion of the tests performed, the CE certification of the tested machine will be issued.

Each **DIECI S.R.L.** product with CE marking is provided with the related certificate, which must be kept by the rightful owner according to the requirements of law.

4.6 Liability

- The machines and equipment are built according to the EC directives in force at the time of sale;
- Failure to follow the instructions for use and safety or the use of the vehicle in good working order can not cause accidents criminal offense;
- The manufacturer is not liable for damage caused to persons, animals or property resulting from improper use of the machine or structural changes, unauthorized applications, and transformations;
- The manufacturer also reserves the right to make any changes to the machine for any technical and commercial requirement without notice.



4.7 Manufacturer

DIECI S.R.L.

Via E. Majorana, 2/4

42027 Montecchio Emilia (RE) ITALY

Tax Code 01283560686 VAT No. 01682740350

Tel. +39 0522 869611 - Fax +39 0522 869744

email: info@dieci.com

4.8 Service Centers

For any problems concerning the use or maintenance, the Operator is required to go directly to the Manufacturer, providing identification data of the equipment found on the machine itself.

4.9 Certification and CE marking

The machine and related equipment are manufactured in accordance with the relevant EU directives and applicable at the time of its release on the market.

L'analisi di tutti i requisiti essenziali per la salute e la sicurezza è stata effettuata durante la progettazione e la costruzione al fine di verificare l'applicabilità e la conseguente conformità. Dove l'analisi ha rilevato un iniziale mancato rispetto, i problemi sono stati corretti con soluzioni appropriate al fine di soddisfare questi requisiti.

Here is shown a facsimile of the certification attached to the machine (Fig. 1-D0101).

DICHIARAZIONE DI CONFORMITA'

(Direttiva macchine 2006/42/CE, allegato II, parte A)

Fabbricante : DIECI SRL
Indirizzo : Via E. Majorana, 2-4- 42027 Montecchio Emilia (RE), Italia

Nome e indirizzo della persona autorizzata a costituire il fascicolo tecnico: SIG. ENNIO MANGHI
presso DIECI SRL- Via E. Majorana, 2-4 - 42027 Montecchio Emilia (RE), Italia

Dichiara che :

L'Autobetoniera Tipo **DH695 (N 2400)** Matricola **DH695******

è conforme a tutte le disposizioni pertinenti delle seguenti Direttive Europee:

- Direttiva Macchine - 2006/42/CE
- Direttiva Compatibilità elettromagnetica - 2004/108/CE
- Direttiva sull'emissione acustica ambientale delle macchine - 2000/14/CE procedura allegato V

Potenza netta installata : ***** kW**

Livello di potenza sonora misurata: $L_{WA_{m}}$ = ***** dB_(A)**

Livello di potenza sonora garantita: L_{WA} = ***** dB_(A)**.

Targa riportante marcatura CE è applicata sulla macchina.

Montecchio Emilia, ****/**/xxxx**

DIECI SRL
Via E. Majorana, 2-4
Montecchio Emilia (RE)
L' Amministratore
Ennio Manghi

4.10 General warnings



- FORBIDDEN

THE MACHINERY AND EQUIPMENT CANNOT BE MODIFIED WITHOUT THE MANUFACTURER'S AUTHORISATION.

To guarantee your safety and that of others, do not modify the structure or adjust the various accessory components of the vehicle or equipment. The same holds true for the deactivation or modification of safety devices present.



- ATTENTION

Any modification made to the vehicle or accessories will absolve *DIECI S.R.L.* from all liability for damage or injury resulting from such modification.

Every machine or equipment comes with a copy of its own manual.



- FORBIDDEN

The total or partial reproduction of this manual or any multi-media enclosures is prohibited.

***DIECI S.R.L.* will protect the ownership rights of these materials.**

A copy of the use and maintenance manual relative to machine parts or equipment of the respective suppliers can be supplied. These manuals are written by the respective product suppliers and reproduced accurately and in full by *DIECI S.R.L.* with their specific authorisation: they can be enhanced with further specifications drawn up by *DIECI S.R.L.*

This Use and Maintenance manual is also provided by the Dealer upon delivery of the vehicle, in order to make sure that these instructions are read and correctly understood.

Should you have trouble understanding any part of this manual, do not hesitate to contact your nearest Dealer for clarification.

All documentation provided constitutes an integral and important part of the product and must always be available to users.

The instructions for use, maintenance and repair described in this handbook must be followed if the vehicle is to be considered as being operated in accordance with the manufacturer's intended uses.

This manual assumes that the health and safety Standards in force are complied with in the place of use of the vehicle and of the equipment.



- ATTENTION

It is compulsory to read and understand this manual before using the machine or various equipment and to carefully follow the indications therein.



- ATTENTION

It is mandatory to have read and learned the machine manual before reading the manuals of the various equipment.



- NOTE

This Use and Maintenance Manual in the user's language, must be carefully stored aboard the vehicle at all times in an accessible and well known place to all users.

If the manual becomes creased and/or be, even partially, damaged or illegible or in case of loss of the manual, it must be replaced immediately by contacting the Dieci Technical Assistance Service, giving the details of the manual found in the "Introduction" chapter.

Local Dealers can supply original spare parts as well as advice and instructions for their installation and use.



- ATTENTION

Use only original spare parts when they are required.

The use of non-original spare parts may cause damage to other parts of the vehicle. Customers are advised to purchase all original spare parts required only from an authorised Agent or Dealer.

***DIECI S.R.L.* does not consider itself liable for damage deriving from the use of non-original spare parts.**

**- ATTENTION**

Should the vehicle or the equipment be intended for use in particularly severe conditions (for example: in dusty environments or worksites, on argillaceous or muddy terrain), it is mandatory to consult your nearest dealer for specific instructions. Failure to observe these instructions may result in the vehicle's guarantee being voided.

**- ATTENTION**

Improper, incorrect, or irrational use of the vehicle or the accessories with which it is equipped as well as modification to its physical structure or functioning is prohibited. A different use is strictly prohibited and relieves *DIECI S.R.L.* from responsibility for damage caused to persons, things or animals.

**- NOTE**

DIECI S.R.L. is not liable for damage caused by negligent use of this vehicle or the accessory even if said damage is not a result of intentional improper use. Everything possible has been done during the design and construction phases of vehicles and accessories to make your job as safe as possible. Due caution, however, is indispensable and there is no better rule to prevent accidents.

**- ATTENTION**

DIECI S.R.L. is not liable for damage resulting from operations performed instinctively, as a reflex, while in a state of panic, or in the event of malfunctioning, accidents or anomaly, during use of the vehicle.

The instructions for use, maintenance and repair described in this handbook must be followed if the vehicle is to be considered as being operated in accordance with the manufacturer's intended uses.

**- ATTENTION**

DIECI S.R.L. reserves the right to carry out possible modifications to the vehicle or accessories for technical or commercial reasons without prior notice.

**- ATTENTION**

To correctly use the components and machine controls recalled in the following pages, refer to the specific use and maintenance manual of the machine.

**- ATTENTION**

Do not modify the structure or adjust the safety devices of the various machine or tool components.

**- ATTENTION**

Only CE equipment certified by the relative manufacturer and approved can be used on *DIECI* machines or that falling within the technical limits set out by *DIECI S.R.L.*.

The interchangeable equipment manufacturer must guarantee that the combination of such equipment and the basic machine on which the equipment is intended for, meets all the basic health and safety requirements, providing an adequate evaluation procedure of compliance.

DIECI S.R.L. liability shall not be involved if equipment use or modifications do not comply with the above mentioned requirements.

**- ATTENTION**

Before commissioning each accessory, ensure compatibility with the vehicle and calibration of the safety system relating to the used accessory.

**- ATTENTION**

Routine maintenance should be carried out regularly, keeping a record of the vehicle's working hours.

**- ATTENTION**

The right and left positions indicated in this manual refer to the view of the operator sitting in the driver's seat (looking forwards).

5 MACHINE DESCRIPTION



- WARNING

The images used to describe components and controls refer to a complete machine with all accessories; these may vary depending on the model and on the configuration chosen.

Positions and references used in this manual refer to the machine facing the normal running direction.

- Front view (Fig. 1-E0000)
- Rear view (Fig. 2-E0000)
- Left side view (Fig. 3-E0000)
- Right side view (Fig. 4-E0000)

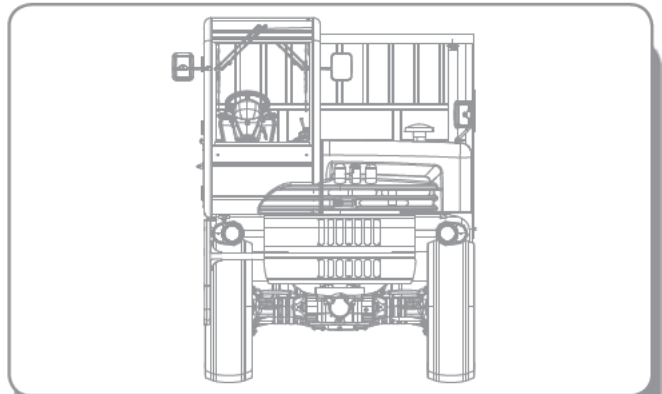

1-E0000

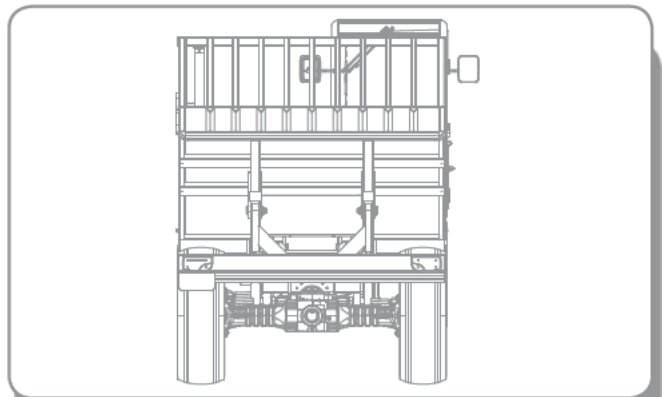

2-E0000

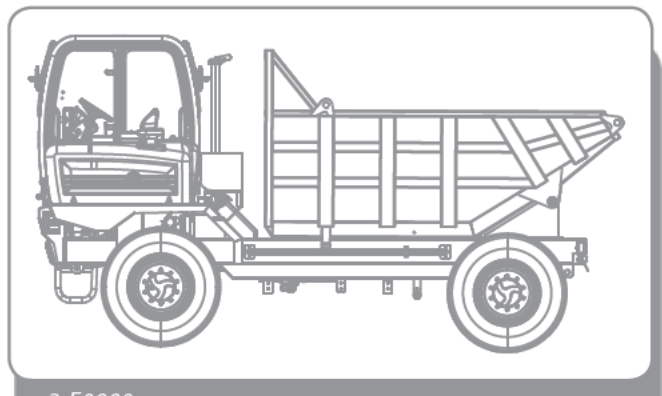

3-E0000

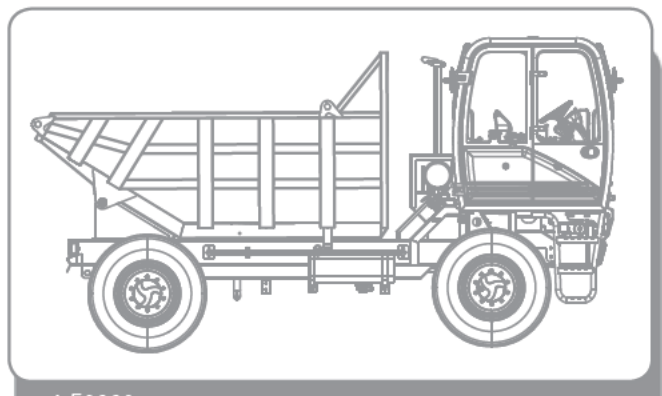

4-E0000

5.1 Main components position

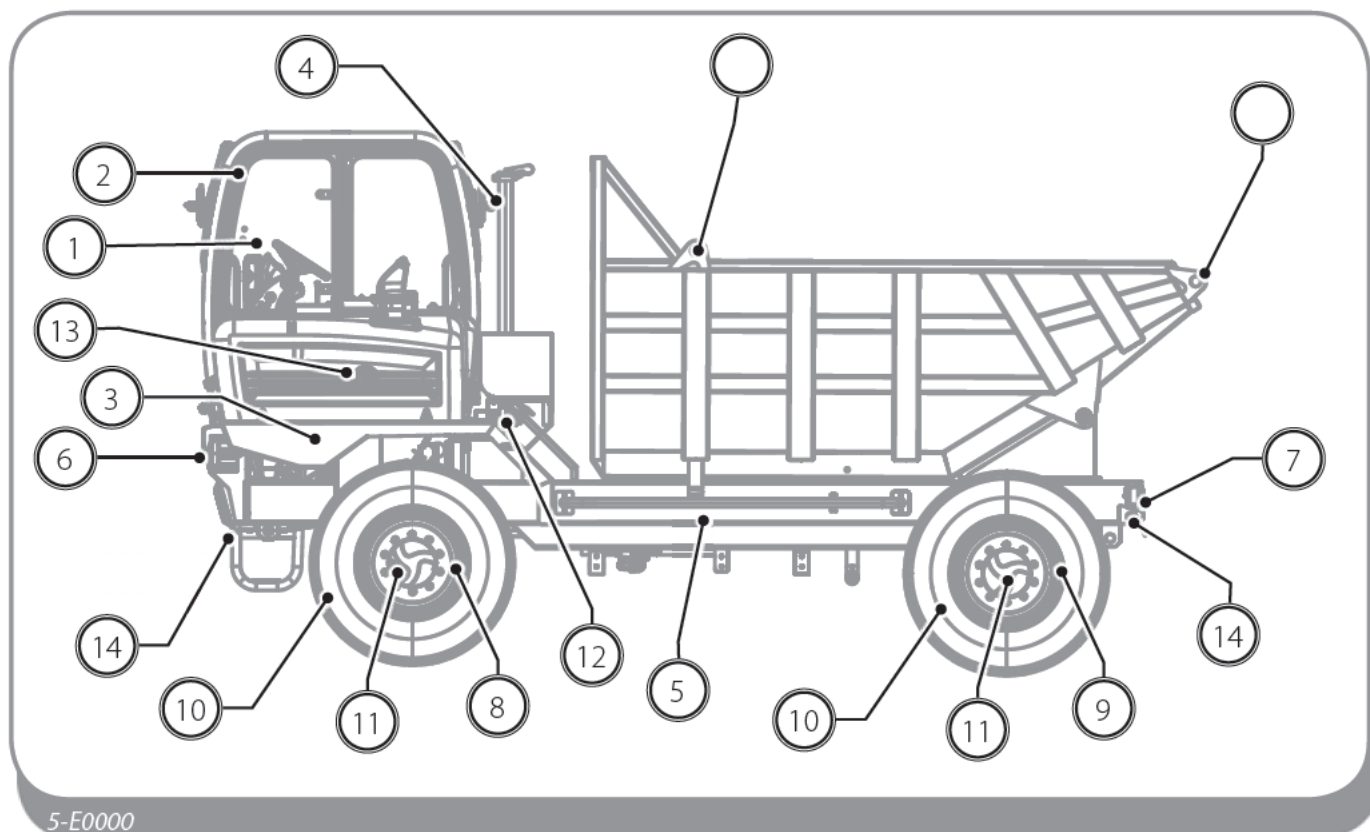

5.1.1 Left side

On the left side (Fig. 5-E0000) are visible:

1	Cab	
2	Cab glass on engine side	* (optional)
3	Engine hood	
4	Exhaust pipe	
5	Chassis	
6	Front lights	
7	Rear lights	
8	Front axle	
9	Rear axle	
10	Wheel	
11	Epicycloidal reduction gear	
12	Emergency stop button	

13	Battery cut-off switch	
14	Anchoring or tow hitch	
15	Hook for lifting	

 * Optional accessories or components.

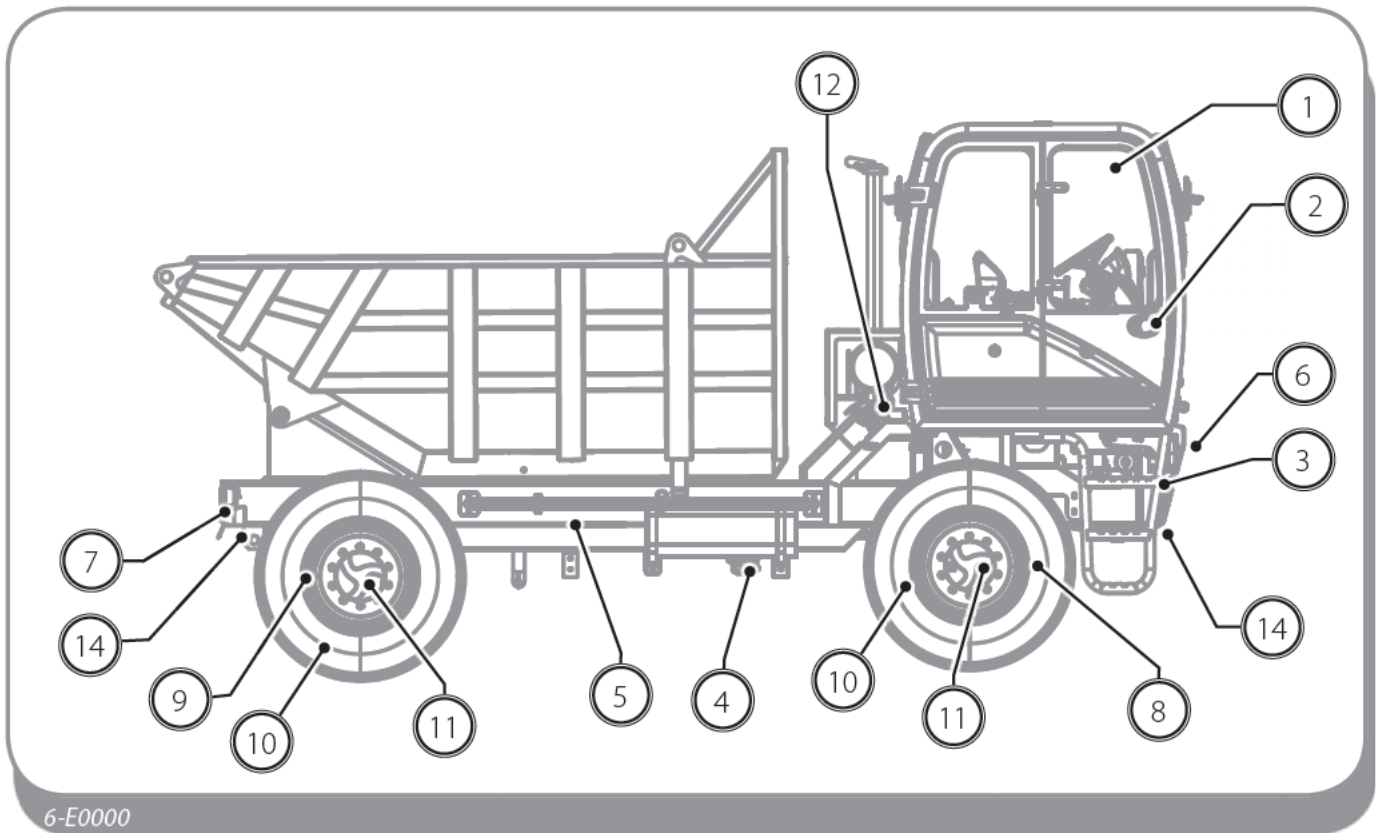

6-E0000

5.1.2 Right side

On the right side (Fig. 6-E0000) are visible:

1	Cab	
2	Door	* (optional)
3	Ladder for climbing on	
4	Fuel tank filler cap	
5	Chassis	
6	Front lights	
7	Rear lights	
8	Front axle	
9	Rear axle	
10	Wheel	
11	Epicycloidal reduction gear	
12	Emergency stop button	
13	Emergency stop button	

14	Anchoring or tow hitch	
15	Hook for lifting	
16	Water tank filler cap	

* **Optional accessories or components.**

5.1.3 Front

On the front side (Fig. 7-E0000) are visible:

1	Cab	
2	Wiper	
3	Front glass	
4	Engine hood	
5	Right front headlight	
6	Right front wheel	
7	Left front headlight	
8	Left front wheel	
9	Rear view mirror	
10	Tilting dump body	

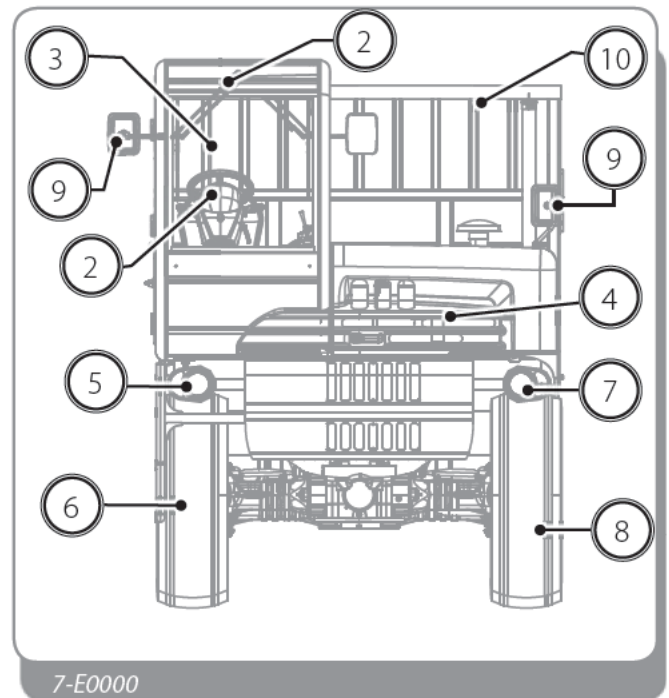

5.1.4 Back

On the back side (Fig. 8-E0000) are visible:

1	Cab	
2	Rear glass	
3	Rear view mirror	
4	Right rear headlight	
5	Left rear headlight	
6	Right rear wheel	
7	Left rear wheel	
8	Tilting dump body	

 * Optional accessories or components.

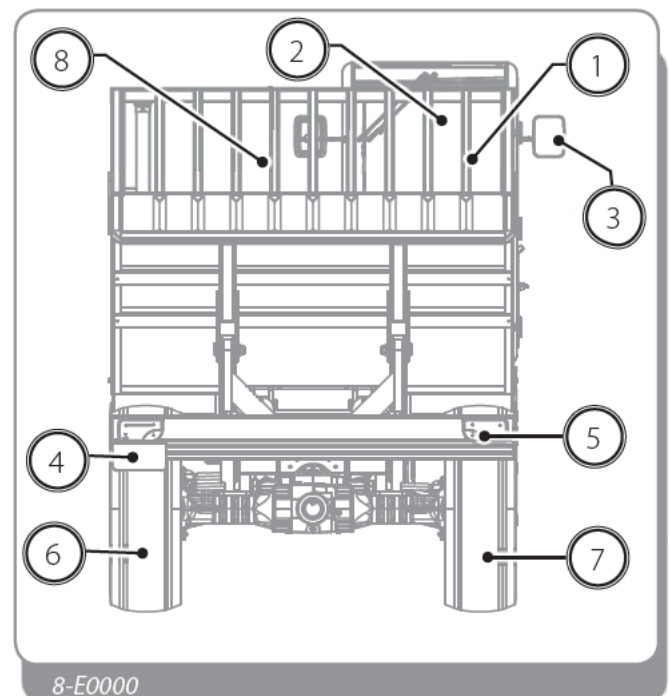

5.1.5 Engine hood

Under the engine hood (Fig. 9-E0000) are visible:

1	Engine	
2	Intake system	
3	Cooling system	
4	Traction pump	
5	Hydraulic tank	
6	Battery	

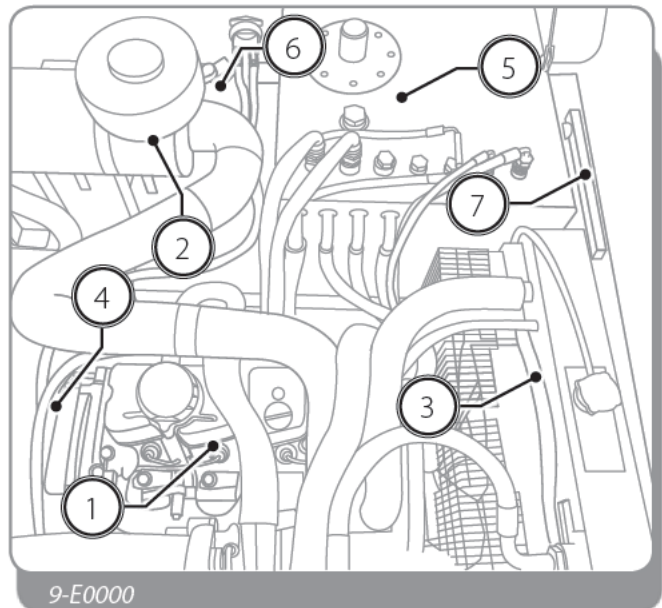

5.1.6 Cab

On the back side (Fig. 10-E0000) are visible:

1	Wiper	
2	Rear view mirror	
3	Revolving driver's seat	
4	Front glass	
5	Rear glass	
6	Glass on engine side	* (optional)
7	Hydraulic scale display	* (optional only on L3500 and L4700)
8	Electronic scale display	* (optional)
9	Handles	
10	Driver's seat reversal pedal	
11	Seat adjustment lever	
12	Seat	
13	Brake fluid tank	
14	Wiper fluid tank	
15	Fuses box	



* Optional accessories or components.

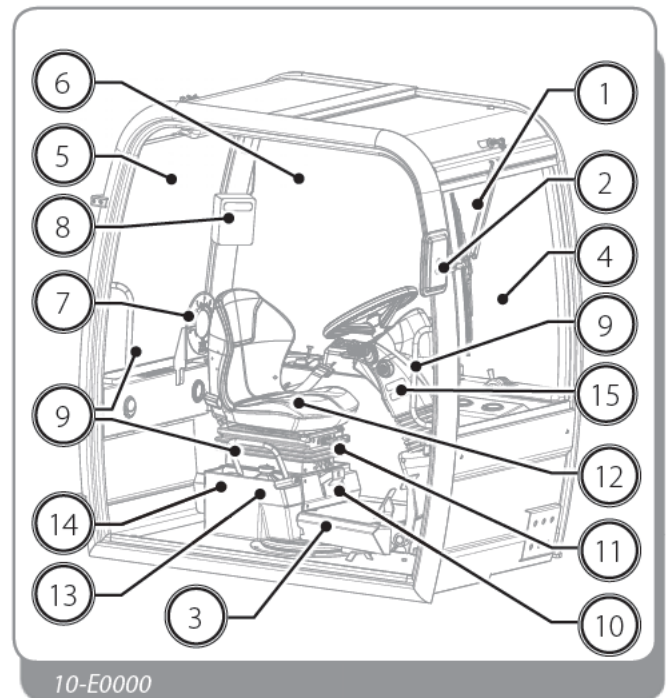

5.1.7 Revolving driver's seat

On the back side (Fig. 11-E0000) are visible:

1	Steering wheel	
2	Instrument panel	
3	Gear lever	
4	Multifunction lever	
5	Steering wheel reversal lever	
6	Inching Pedal	
7	Brake pedal	
8	Accelerator pedal	
9	Seat	
10	Seat belts	
11	Brake fluid tank	
12	Wiper fluid tank	

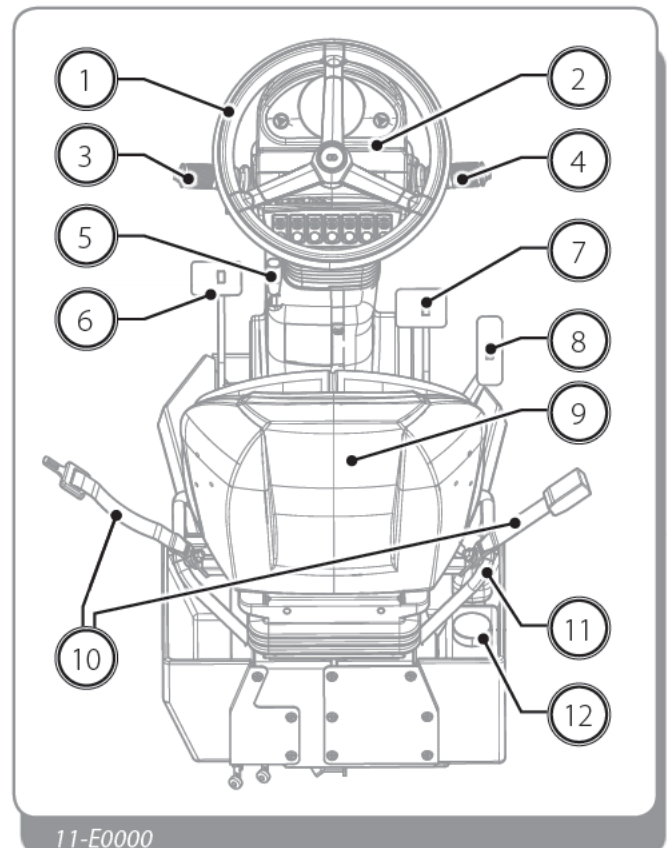

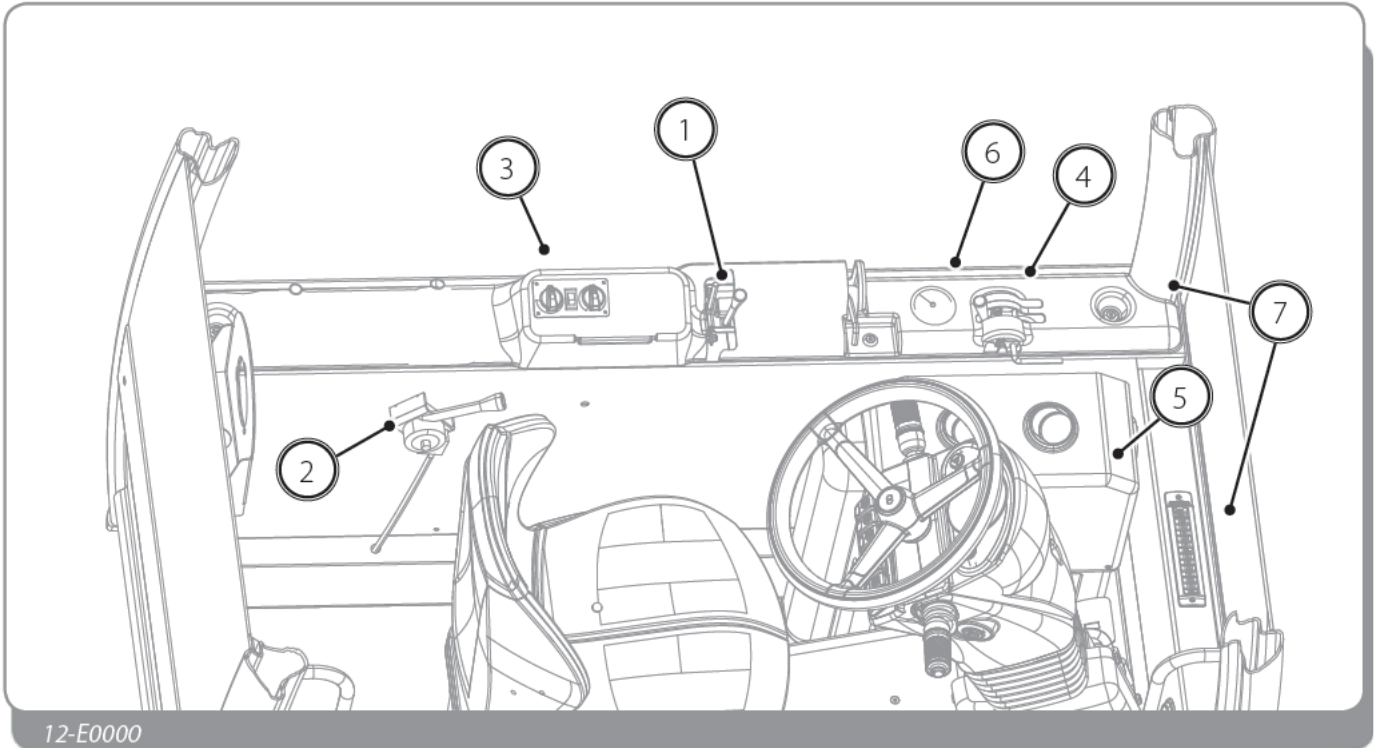

5.1.8 Left instrument panel

On the left instrument panel (Fig. 12-E0000) there are:

1	Dump body movement lever	
2	Hand throttle control lever	
3	Heating/air conditioning controls	* (optional)
4	Steering mode control lever	
5	Heating/air conditioning system	* (optional)
6	Brake pressure gauge	only 7000
7	Air vents	

 * Optional accessories or components.

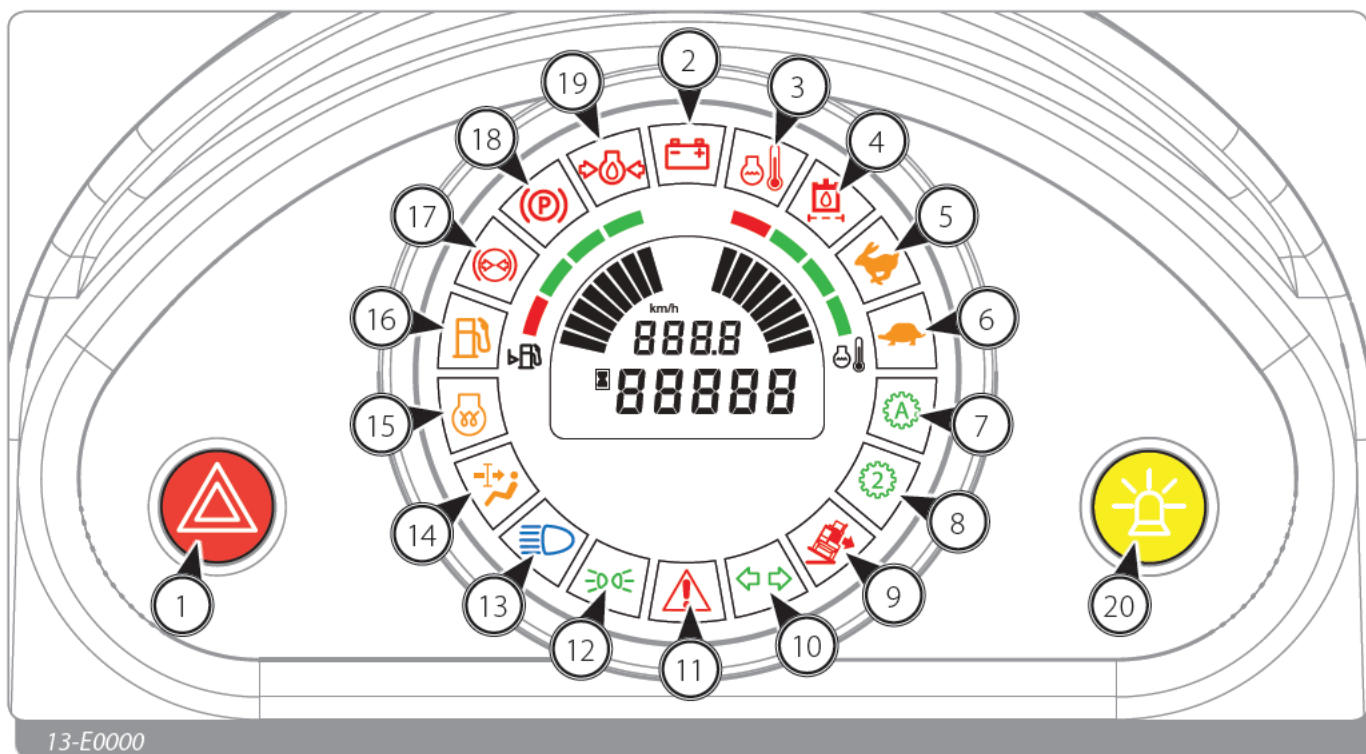

13-E0000

5.1.9 Instrument panel

On the back side (Fig. 13-E0000) are visible:





1		Emergency lights switch (Red)
2		Generator, battery failure (Red)
3		Engine water high temperature (Red)
4		Hydrostatic oil filter failure (Red)
5		Fast gear (Yellow)
6		Slow gear (Yellow)
7		Manual gear correctly engaged (Green)
8		Fast gear correctly engaged (Green)
9		Not used (Red)
10		Direction indicators (Green)

11		General alarm (Red)
12		Side lights (Green)
13		High beam (Blue)
14		Reversed power steering (Yellow)
15		Thermostarter (Yellow)
16		Low fuel level (Yellow)
17		Parking brake insufficient pressure (Red)
18		Parking brake engaged (Red)
19		Engine oil failure (Red)
20		Rotating light switch (Yellow)



5.1.10 LCD display



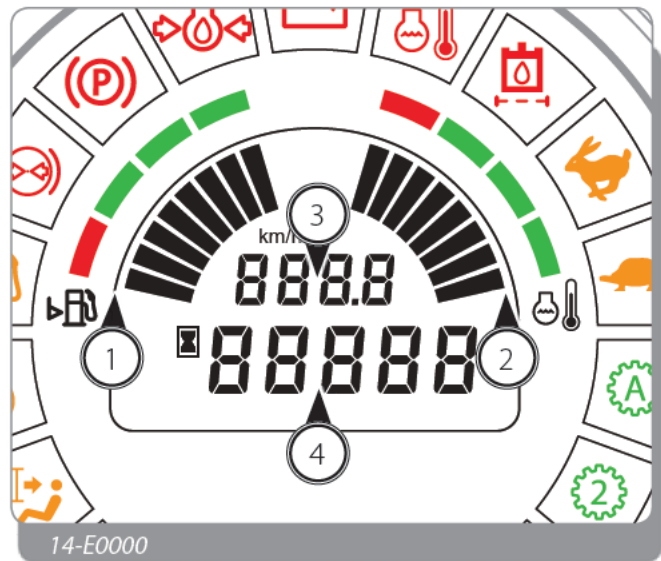

On the left instrument panel (Fig. 14-E0000) there are:

1		Fuel level indicator
2		Engine oil temperature indicator
3		Tachometer
4		Hourmeter



5.1.11 Central instrument panel

On the left instrument panel (Fig. 15-E0000) there are:

1		Front wiper switch (Green)
2		Rear wiper switch (Green)
3		Not used
4		Slow/fast gear shift button (Green)
5		Parking brake switch (Red)

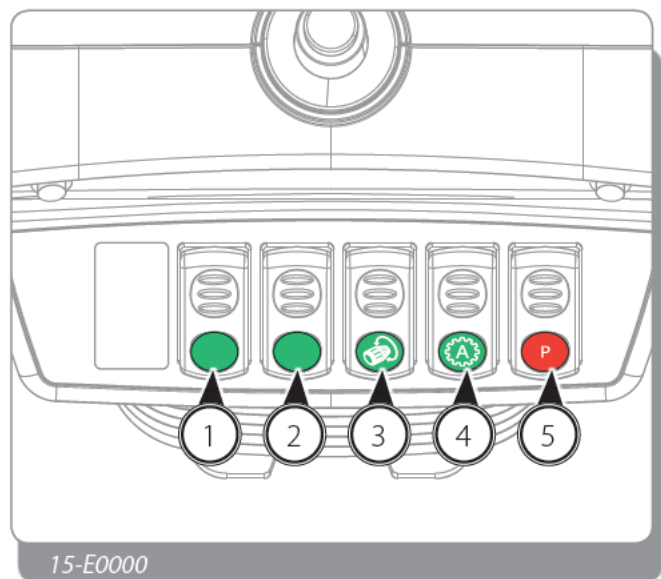

5.2 Technical data

5.2.1 Dimensions

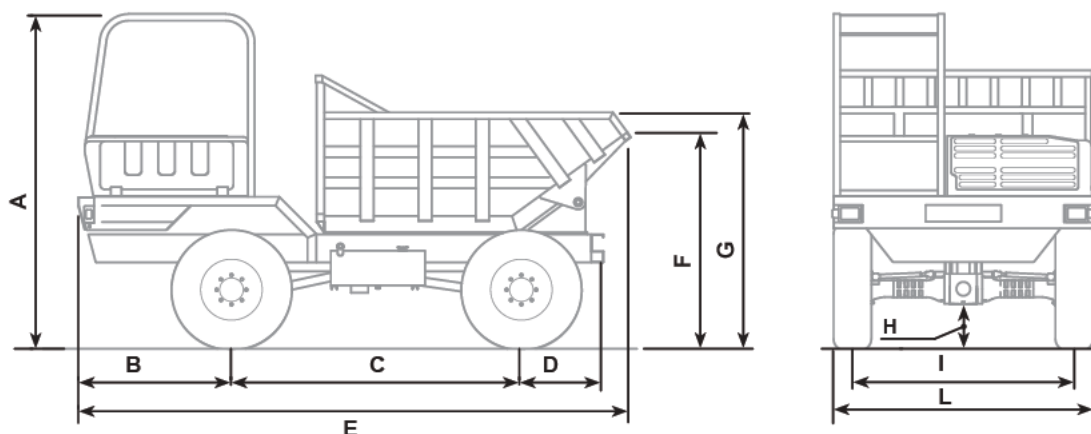

	DP 4200	DP 7000
DIMENSIONS		
A	3010 mm (118.5 in)	3010 mm (118.5 in)
B	1370 mm (53.93 in)	1370 mm (53.93 in)
C	2600 mm (102.36 in)	2600 mm (102.36 in)
D	740 mm (29.13 in)	740 mm (29.13 in)
E	4960 mm (195.27 in)	4960 mm (195.27 in)
F	1940 mm (76.37 in)	1940 mm (76.37 in)
G	2120 mm (83.46 in)	2120 mm (83.46 in)
H	385 mm (15.15 in)	385 mm (15.15 in)
I	1920 mm (75.59 in)	1920 mm (75.59 in)
L	2350 mm (92.51 in)	2350 mm (92.51 in)
PERFORMANCE		
Capacity	8500 kg (18730 lb)	8500 kg (18730 lb)
Dump body capacity (level)	5900 m ³ (7729 yd ³)	5900 m ³ (7729 yd ³)
Dump body capacity (heaped)	6150 m ³ (8056 yd ³)	6150 m ³ (8056 yd ³)
Hydraulic tilting	Rear	Rear



	DP 4200	DP 7000
ENGINE		
Model	Iveco NEF	Iveco NEF
Maximum power	93 kW (125 Hp)	93 kW (125 Hp)
Revolutions per minute	2200 rpm	2200 rpm
Operation	4-stroke diesel	4-stroke diesel
Injection	Mechanical direct	Mechanical direct
Number and arrangement of cylinders	4, vertical in line	4, vertical in line
Displacement	4485 cm ³ (273 in ³)	4485 cm ³ (273 in ³)
Fuel	Diesel	Diesel
Specific consumption at 2600 rpm	230 g/kWh (378.35 lb/Hp h)	230 g/kWh (378.35 lb/Hp h)
Engine sizes	Turbo compressor	Turbo compressor
Cooling	Liquid cooling system	Liquid cooling system
Fuel tank capacity	90 l (19.79 IMP gal)	90 l (19.79 IMP gal)
TRANSMISSION		
Hydrostatic	Variable displacement pump	Variable displacement pump
Hydraulic motor	Automatic adjustment	Automatic adjustment
Reversal	Electro-hydraulic that can be operated also in movement	Electro-hydraulic that can be operated also in movement
Transmission gearbox	Servocontrolled 2-speed	Servocontrolled 2-speed
DIFFERENTIAL AXLES		
Front axle	Steering, self-locking with planetary reduction gears	Steering, self-locking with planetary reduction gears
Rear axle	Steering, self-locking, rigid with planetary reduction gears	Steering, self-locking, rigid with planetary reduction gears
Type of steering	4 wheels / transversal / 2 wheels	4 wheels / transversal / 2 wheels
Service braking	Oil bath on 4 wheels	Oil bath on 4 wheels
Parking braking	Negative brake on the rear axle	Negative brake on the rear axle
HYDRAULIC SYSTEM AND DRUM		
Hydraulic oil tank capacity	120 l (26.38 IMP gal)	120 l (26.38 IMP gal)
Hydraulic system oil	145 l (31.88 IMP gal)	145 l (31.88 IMP gal)
Hydraulic pump	With open circuit gear with drum rotation speed regulator	With closed circuit axial pistons with drum rotation speed regulator
Gearbox	Hydraulic coaxial	Hydraulic coaxial
ACOUSTIC PRESSURE		
In compliance with Directive 2009/76/EC		
- Perceived by the operator	89.5 dB (A)	89.5 dB (A)
ACOUSTIC POWER		
In compliance with Directive 2000/14/EC		
- Measured value	99 dB (A)	99 dB (A)
- Guaranteed value	101 dB (A)	101 dB (A)

	DP 4200	DP 7000
VIBRATIONS		
Declared vibration emission value according to EN 12096 Values determined according to EN 1032. In compliance with Directive 78/764/EEC.		
- Vibrations at the seat	1,1 m/s ² ± 0,5 m/s ² (3,6 ft/s ² ± 1,6 ft/s ²)	1,1 m/s ² ± 0,5 m/s ² (3,6 ft/s ² ± 1,6 ft/s ²)
- Vibrations at the steering wheel	2,2 m/s ² ± 1,1 m/s ² (7,2 ft/s ² ± 3,6 ft/s ²)	2,2 m/s ² ± 1,1 m/s ² (7,2 ft/s ² ± 3,6 ft/s ²)



LUBRICANTS TABLE	DP 4200	DP 7000	TYPE
Engine oil	10.0 l (2.19 IMP gal)	10.0 l (2.19 IMP gal)	- 15W-40 ACEA E7 / API CI-4 - 10W-30 ACEA E7 / API CI-4 - 10W-40 ACEA E9/API CJ-4
Front axle differential oil, central gearbox	7.4 l (1.62 IMP gal)	7.2 l (1.58 IMP gal)	- SAE 85W90 - API GL4 - MIL L-2105
Front axle differential oil, end reductions	1.0 l (0.21 IMP gal)	1.9 l (0.41 IMP gal)	
Rear axle differential oil, central gearbox	7.4 l (1.62 IMP gal)	7.5 l (1.64 IMP gal)	
Rear axle differential oil, end reductions	1.0 l (0.21 IMP gal)	1.9 l (0.41 IMP gal)	
Transmission gearbox	1.7 l (0.37 IMP gal)	1.5 l (0.32 IMP gal)	- SAE85W90 - API GL3
Braking circuit oil	1.2 l (0.26 IMP gal)	1.5 l (0.32 IMP gal)	DEXRON II
Coolant	7.0 l (1.53 IMP gal)	7.0 l (1.53 IMP gal)	- ASTM D 2570 - ASTM D 3440 - ASTM D 1384 - ASTM D 2809 - ASTM D 3306 - SAE J - 1036 - CUNA NC 956-16 - NF R 15601 BS 6580 - RENAULT 41-01-00/9 D - VWTL 774D
Grease	4.0 kg (8.81 lb)	4.5 kg (9.92 lb)	NLGI - 1
Hydraulic oil tank capacity	120 l (26.38 IMP gal)	120 l (26.38 IMP gal)	Hydro telehandler fluid ISO46 (see next page)



- CAUTION

Unless otherwise indicated or according to arrangements required by the customer, the hydraulic system of the machine is supplied with oil:

DIECI Hydro Telehandler Fluid ISO46

Specifications:

ISO 6743-4 HV, Afnor NFE 48-602, ISO 11158, DIN 51524 Part 3 HVL, Afnor NFE 48-603 HV, ASTM D6158, Denison HF-0 / HF-1 / HF-2, Eaton Vickers I-286-S / M-2950-S, Cincinnati Machine P-68 / P-69 / P-70, Afnor NFE 48-690(dry), Afnor NFE 48-691(wet), U.S. Steel 126 / 127 / 136, JCMAS HK, Bosch variable vane pumps, Rexroth RE 90220, Sauer Danfoss 520L0463, General Motors (LS-2) LH-03-1 / LH-04-1 / LH-06-1, SEB 181222.

Classification:

ASTM D 6080: ISO VG 46 / L32 - 42 (140)

Properties	Analysis method	Unit of measure	ISO 46 value
Density at 15°C	ASTM D1298	kg/l	0.88
Kinematic viscosity at 40°C	ASTM D445	cSt	46.6
Kinematic viscosity at 100°C	ASTM D445	cSt	8.6
Viscosity Index	ASTM D2270	-	165
Kinematic viscosity at 40°C after Sonic Shear	ASTM D445	cSt	41.6
Viscosity Index after Sonic Shear	ASTM D2270	-	144
FZG Failure Load Stage	ASTM D5182	Stage	12
Flash Point (C.O.C.)	ASTM D92	°C	210
Pour point	ASTM D97	°C	-35
Temperature for Brookfield viscosity of 750cP	ASTM D2983	°C	-9



5.2.2 *Environmental conditions*

Although the machine can be used in several different situations, however, it is necessary to observe, as a precautionary measure, compliance with minimum standards of operation as specified below:

Parameter	Allowed values
Operating temperatures	from -20°C to +40 °C (from -4 °F to 104 °F)
Average daily temperature	< +40 °C (< 104 °F)
Storage temperature	from -25°C to +50 °C (from -13 °F to 122 °F)
Humidity	from 20 % to 95 %
Altitude	< 2500 m (< 8200 ft)

5.2.3 *Electromagnetic Interference*

In the case of additional equipment installed by the customer, the user must verify if the installation causes interference of any kind with the tools of the vehicle; if so, the user must correct such interferences.

It is essential to pay particular attention to mobile devices such as radio communications (telephones) that must be installed by trained service technicians and must use externally mounted antennas.

In general, it should be kept in mind that any additional electrical equipment installed must comply with the EMC Directive 2004/108/EC and must bear the "CE" mark.

5.2.4 *Radiations*

The machine, in conditions of normal use, does not produce any type of radiation, ionizing and non ionizing, that can cause problems to the operator.

6 SAFETY DEVICES

6.1 Safety stickers

Some safety stickers have been applied on the machine in the positions shown below. Their purpose is to provide a guide for your own and others safety. Before starting to work with the machine, check the content and location of the safety stickers turning around the machine with this manual in hand. Review the safety stickers with all operators who will use the machine.



- CAUTION

Make sure to have fully understood their correct location and their contents.

To ensure proper interpretation verify that they are in the correct position and that they are always kept clean.



- DANGER

Clean them when they are covered by mud, concrete or debris.



- PROHIBITION

Do not under any circumstances remove the safety stickers.



- PROHIBITION

It is absolutely forbidden to clean the messages on the machine using solvents or gasoline; the stickers may become discolored. The stickers in addition to those of care and safety must always be treated in the same way.



See the summary table in the "Maintenance" chapter for the for safety stickers maintenance and control deadlines.



Replace the safety stickers in case of deterioration, damage or loss, as these must always be read and interpreted correctly.











- WARNING

The purchase order of replacement safety stickers must be made in the same way in which any spare part is ordered (be sure to communicate the model and serial number of the machine when placing the order).

6.1.1 Meaning of safety stickers

SIGNAL	CODE	DESCRIPTION
	AXA1210	Indicates the functions of the steering mode lever
	AXA1425	Danger of crushing, use safety fasteners for maintenance
	AXA1425	Danger, keep a safe distance from the machine
	AXA1425	Danger, moving mechanical parts
	AXA1425	Danger, stop the engine before performing any maintenance
	AXA1425	Danger, stop the engine and remove the ignition key during maintenance operations
	AXA1425	Danger, comply with the safety distances from electrical lines
	AXA1427	Indicates where to refuel
	AXA1428	Indicates the tire pressure

SIGNAL	CODE	DESCRIPTION
	AXA1431	Indicates the lifting points
	AXA1432	Indicates the points at which to anchor the machine for transport or towing
	AXA1433	Indicates where to check the hydraulic oil level
	AXA1434	Indicates where refueling hydraulic oil
	AXA1435	Danger, moving mechanical parts, do not remove the safety guards and wait that the parts have stopped before carrying out any maintenance
	AXA1438	Indicates machine parts that can not be walked on
	AXA1439	Danger moving mechanical parts
	AXA1440	Danger of hot steam under pressure escaping

SIGNAL	CODE	DESCRIPTION
	AXA1441	Danger of hot surface
	AXA1492	Indicates the position of the brakes oil tank and the type of oil to use
	AXA1497	Indicates the hand throttle function
	AXA1498	Indicates the position and instructions for using the battery cut-off switch
	AXA1499	Danger, comply with the safety distances from electrical lines
	AXA1501	Indicates greasing points
	AXA1506	Compulsory use of seat belts
	AXA2089	Caution, hydraulic circuit with pressure accumulators

6.1.2 Safety stickers position on the machine

The positions of the safety stickers on the machine are shown in figures Fig. 1-F0000 and Fig. 2-F0000.

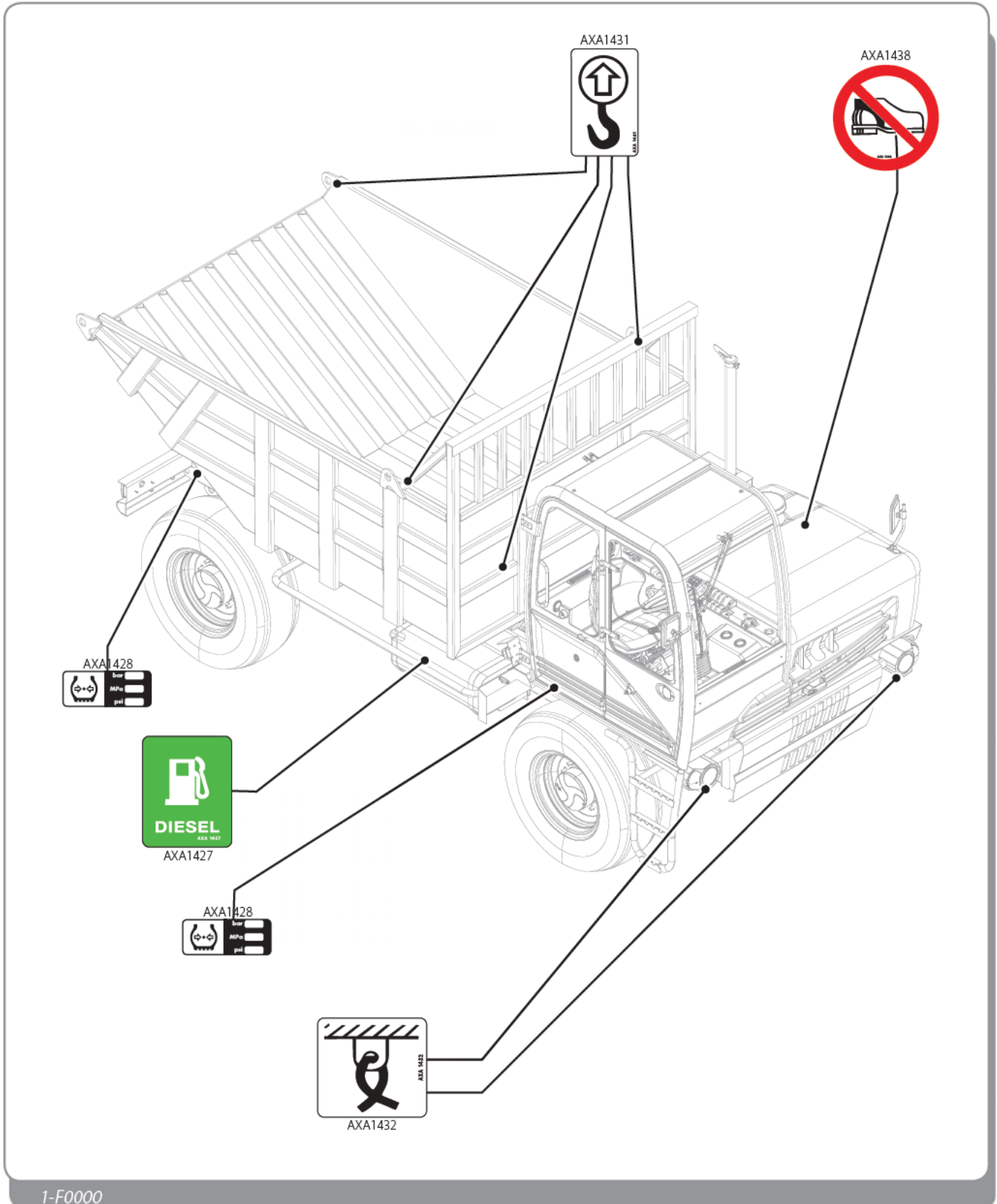

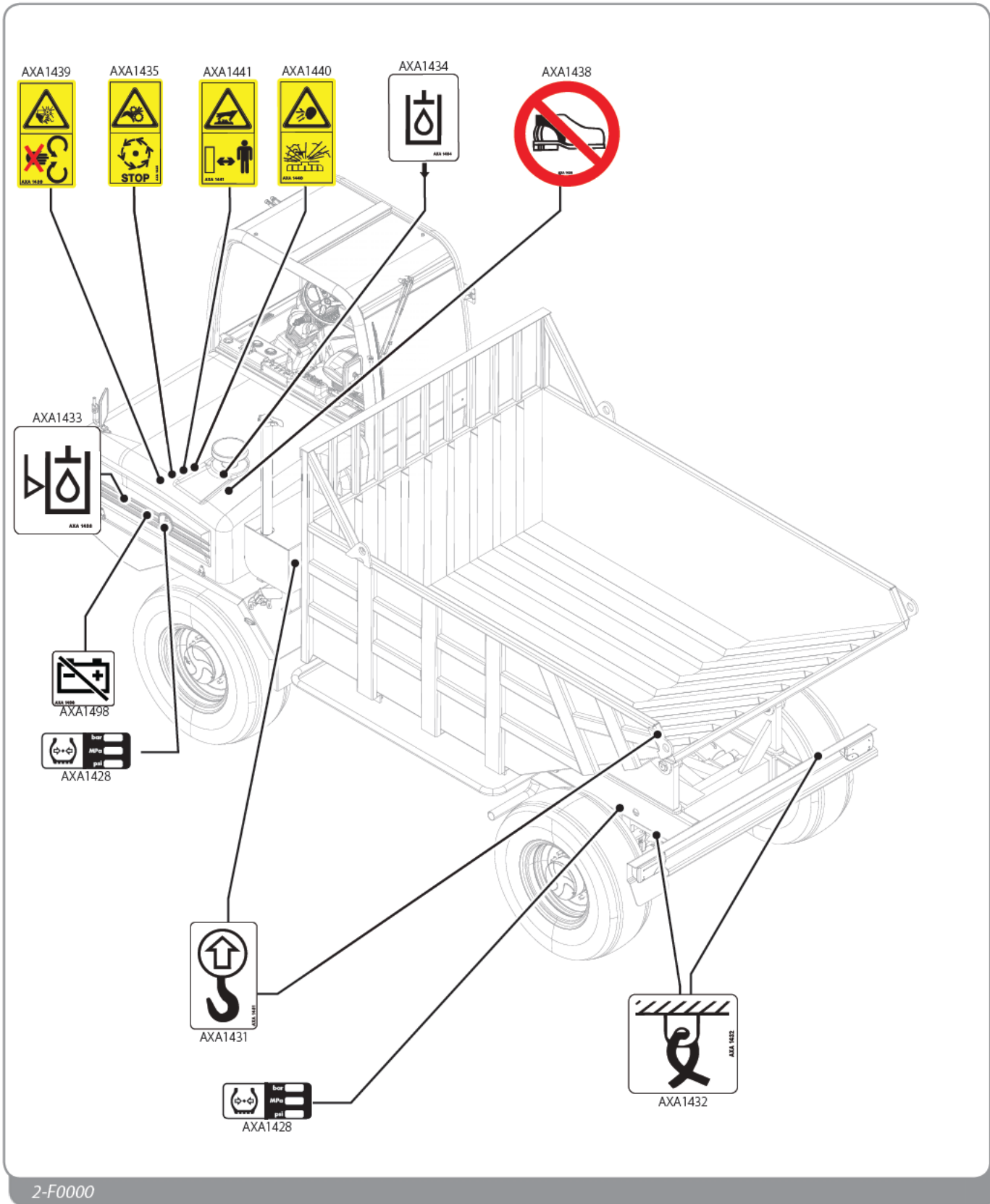

2-F0000

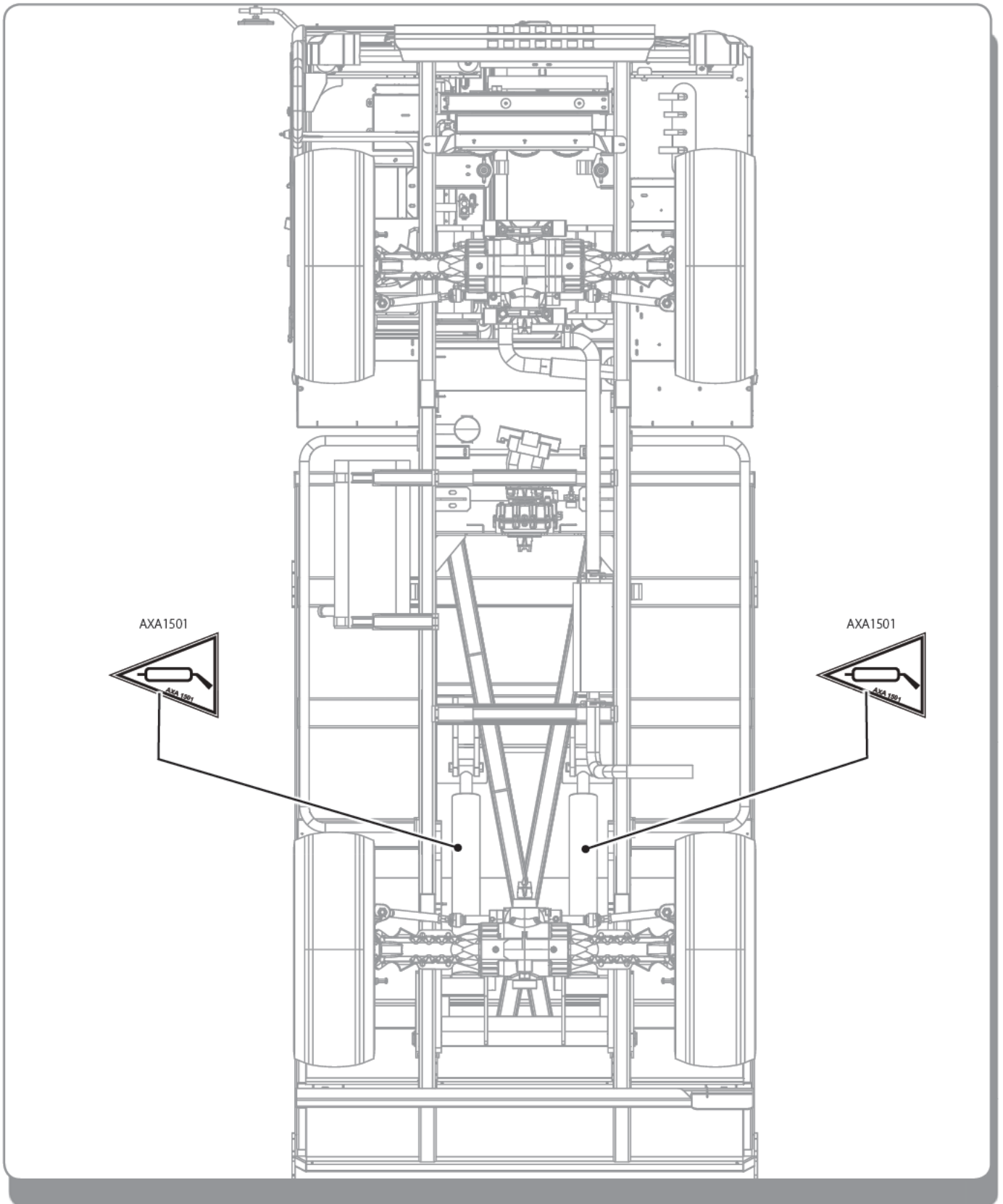



6.1.3 Safety stickers position in the cab

The positions of the safety stickers in the cab are shown in figures Fig. 3-F0000 and Fig. 4-F0000.

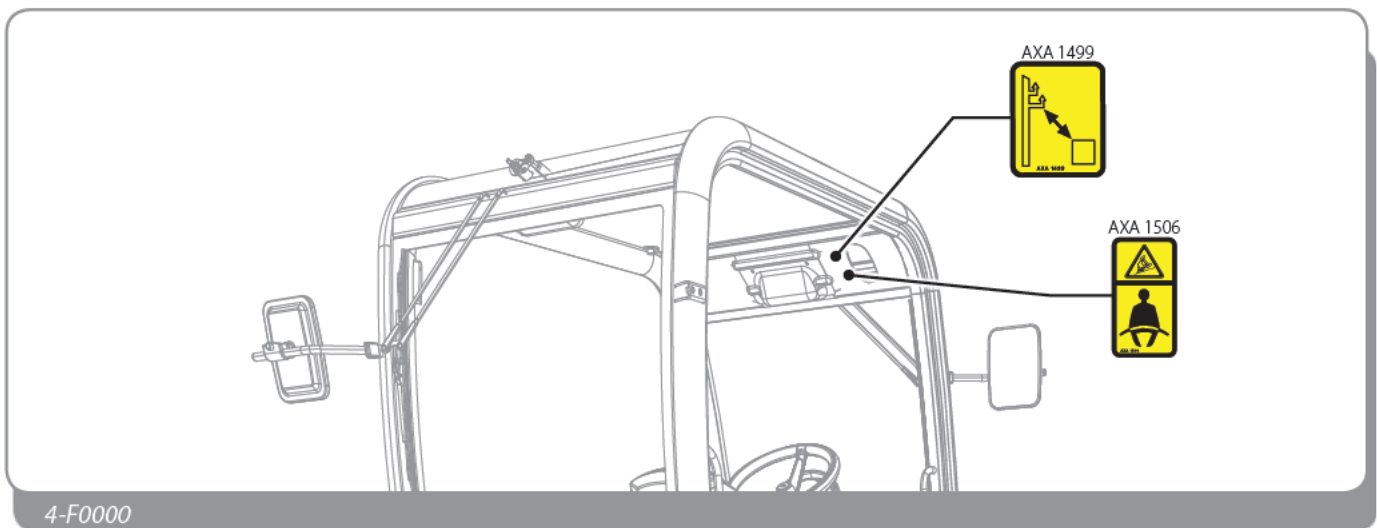
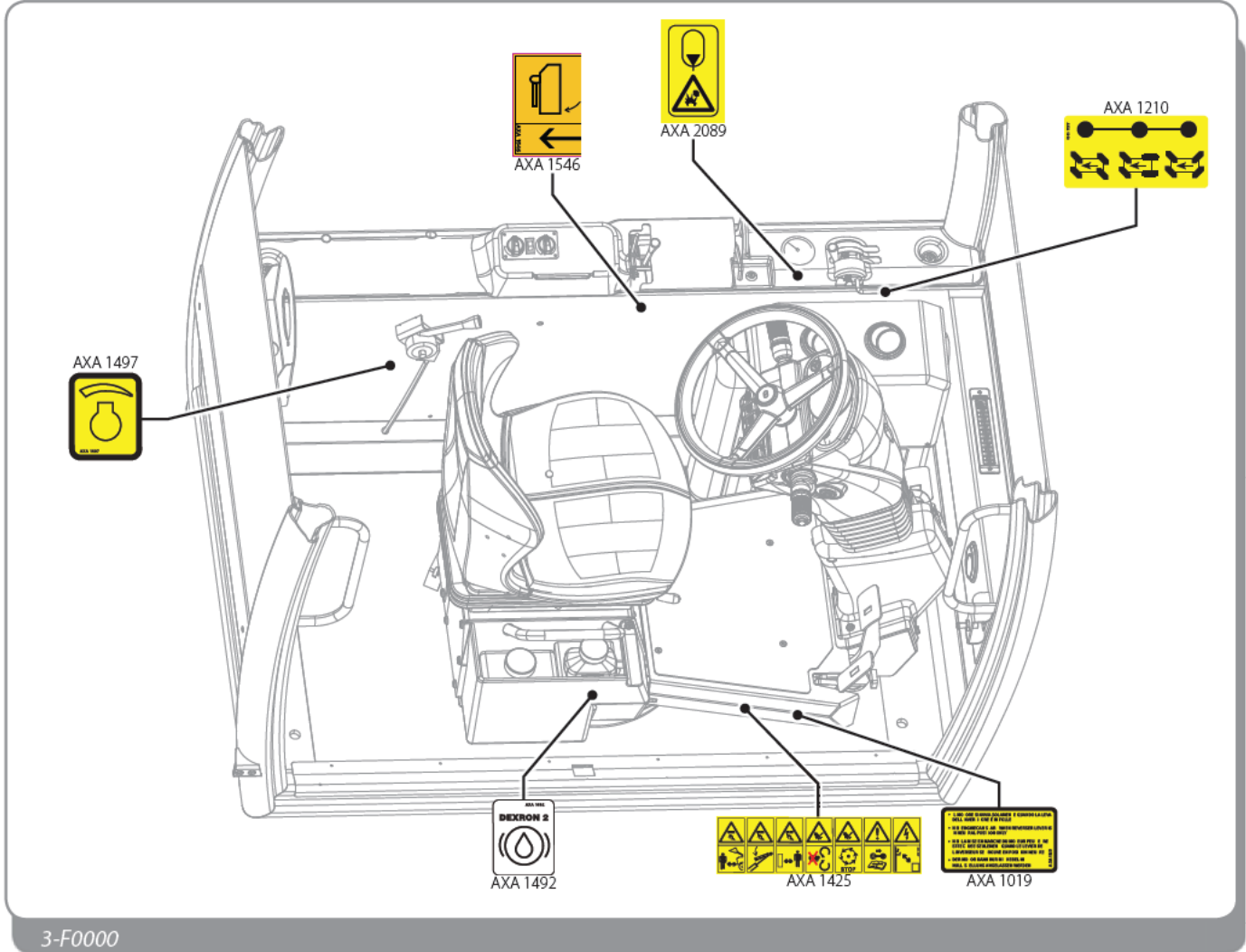

6.2 Parking brake switch

With the parking brake engaged (Fig. 1-F0100) the machine cannot move; the hydrostatic transmission is switched off.



For more information, see the "components description and use" chapter.

6.3 Gear selection lever

While holding the lever (Fig. 2-F0100) in an intermediate position ("N") the transmission is in neutral and the machine is partially braked.

With the forward/reverse gear selection lever in position other than "N", the engine will not start.



For more information, see the "components description and use" chapter.

6.4 Emergency stop switch

The pressure exerted on the emergency stop button (Fig. 3-F0100) activates the power supply cut-off and the consequent complete shutdown of the operating machine.



For more information, see the "components description and use" chapter.

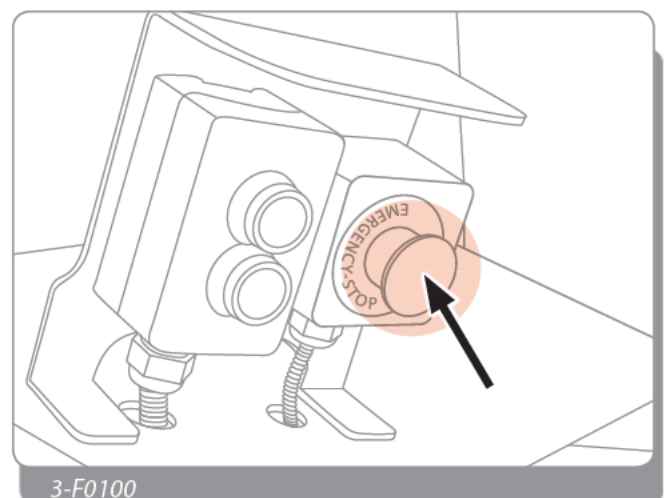
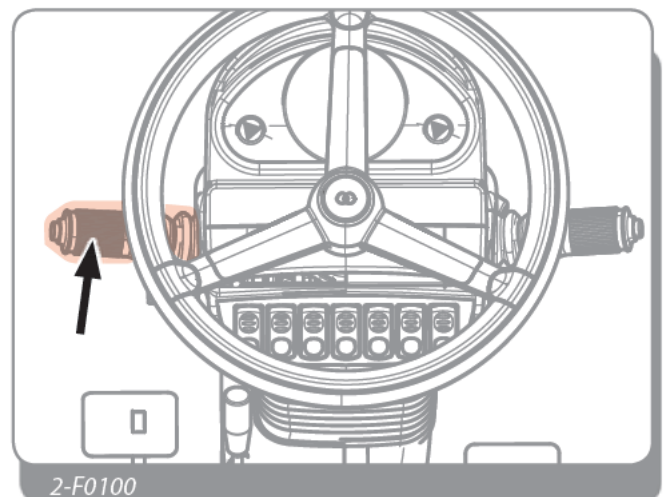
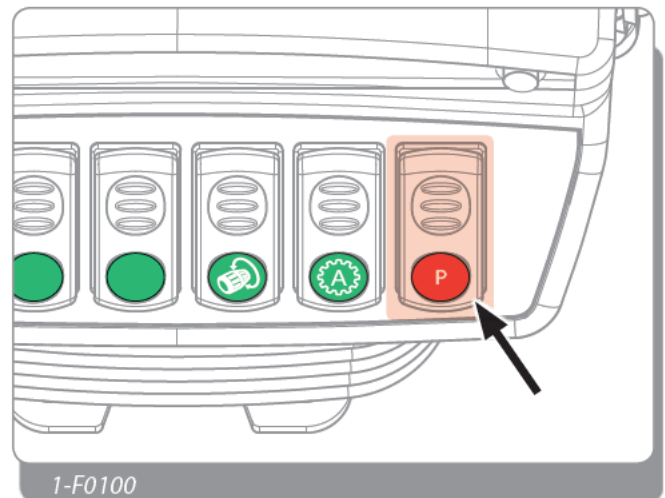

6.5 Anti-accidental operation devices

The safety locks on the levers (Fig. 4-F0100) prevent accidental activation of a control.



- CAUTION

The water pump control lever locking in the cab, also affects the control lever of the pump placed outside the cab.



- CAUTION

After using the levers always restore the safety devices.



For more information, see the "components description and use" chapter.

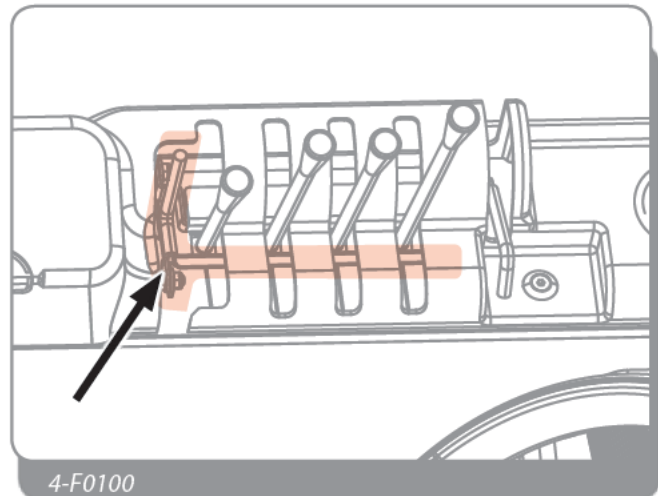

4-F0100

6.6 Seat

- The seat of the machine is equipped with specific safety belts designed to protect the operator during the movement or handling operations.



- CAUTION

Always fasten the seat belts when operating the machine.

- The machine is equipped with a safety system called "deadman" which includes an electric micro-switch inside the seat cushion.



- CAUTION

The engine can be started only if the operator is seated properly in the driving seat and the gear lever is in neutral "N".



For more information, see the "components description and use" chapter.

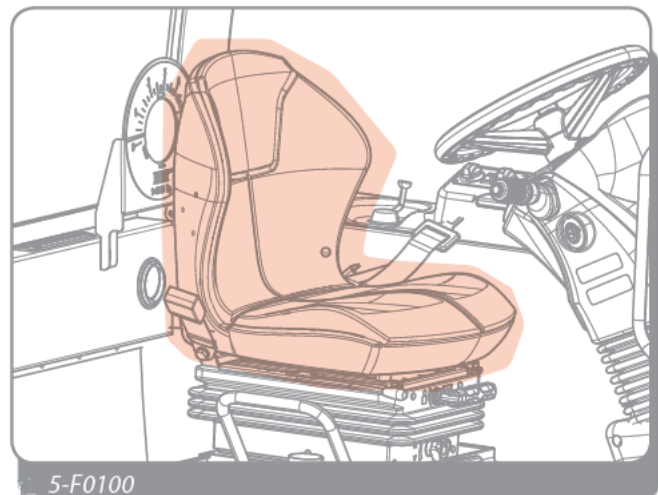

5-F0100

6.7 ROPS - FOPS Cab

The machine is equipped with a ROPS and FOPS approved cab (Fig. 6-F0100). The operator is therefore protected in the event of vehicle tipping and falling objects, as prescribed for earth moving machines.

During use, avoid impacts of the driver against the internal structures of the cab; it is compulsory to use the seat belt. The rear glass can be used as an emergency exit.



If the cab has undergone visual damage it must be replaced by consulting the authorized service center or Dieci authorized workshop.



- CAUTION

The cab is a safety device and as such it must be always kept in the right conditions of use.



- PROHIBITION

It is absolutely forbidden:

- change, drill, or alter in any way the structure of the cab. In case of tampering, the manufacturer has no civil liability.
- weld or mechanically connect parts to the cab chassis.
- Do not connect chains or ropes to the cab for the purpose of towing.



If the fastening bolts are replaced, only use elements of the same strength class.



- DANGER

In the case of machine tipping, do not try to exit the cab during the accident.

Staying in the cab with fastened seat belts provides a better protection.

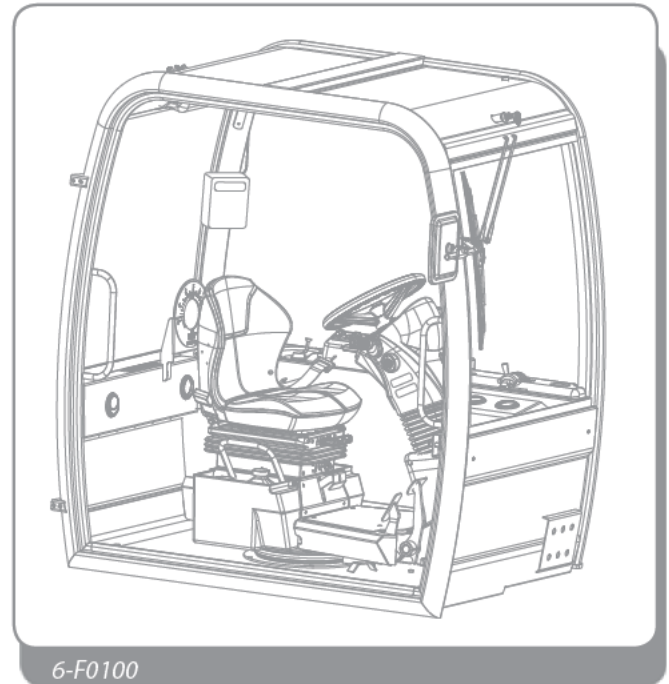

6-F0100

7 COMPONENTS DESCRIPTION AND USE

7.1 General warnings for use

The images, descriptions, dimensions, included in this chapter refer to the standard machine.

Your machine, for your request, can be equipped with optional controls and accessories.



- CAUTION

Before operating the hydraulic moving parts of the machine, make sure that the surrounding area is clear.



- CAUTION

The machine must be used only by competent and qualified personnel, who must have read this manual and performed adequate training in compliance with the regulations in force in the country of use of the machine. If the machine is used on the road, make sure that the operator is in possession of a valid driver's license in accordance with the laws in force in the country of use.



- PROHIBITION

It is prohibited to operate the machine if this chapter has not been carefully read and learned.



- PROHIBITION

Do not use the machine in a state of drunkenness, under the use of drugs or if medicines that can cause drowsiness or impair reflexes have been taken.



- WARNING

Before starting to use the machine, or before performing particularly complex or dangerous operations, it is absolutely necessary to practice in a clear work area of the site free from obstructions.

Next to each control there is a clear and elemental symbol for the operator's better convenience and understanding.



- DANGER

If parts that can produce risk are faulty, stop the machine immediately. Do not resume the machine use until the fault is eliminated.

7.2 Central instrument panel

7.2.1 Fuel level indicator

The instrument (Fig. 1-G0000) indicates the amount of fuel in the tank at that time.

The maximum amount is indicated by the presence of eight segments on the LCD (Fig. 1-G0000, pos 1). The segments will decrease gradually until arriving at the minimum reserve level (Fig. 1-G0000, pos 2), also indicated by the same yellow light.

The presence of only one segment, indicates the absence of fuel.



- CAUTION

To avoid damaging the engine it is recommended to maintain the fuel level always above the minimum level.

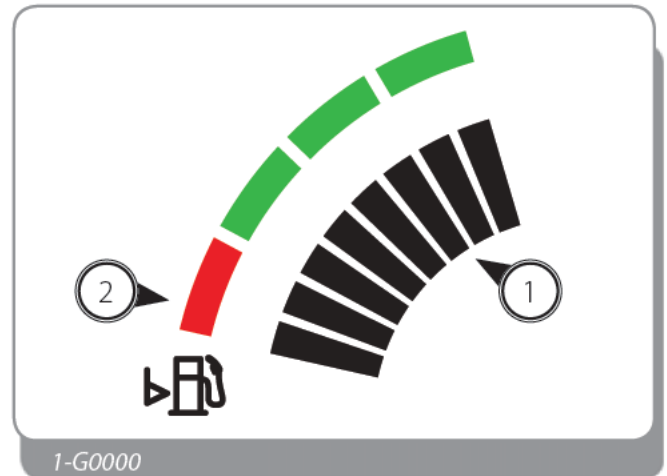

7.2.2 Engine oil temperature indicator

The instrument (Fig. 2-G0000) indicates the engine oil temperature. In normal use it moves from the lower part of the instrument (green zone) stopping when it reaches the first quarter of scale; this is the optimal condition of work for the engine.

If the temperature should rise excessively going close to the maximum level (red zone) or if the engine oil high temperature indicator light on the instrument panel should turn on, stop the engine and check the cause.



- CAUTION

To avoid damaging the cold engine, operate at low speed until the oil reaches the correct temperature.

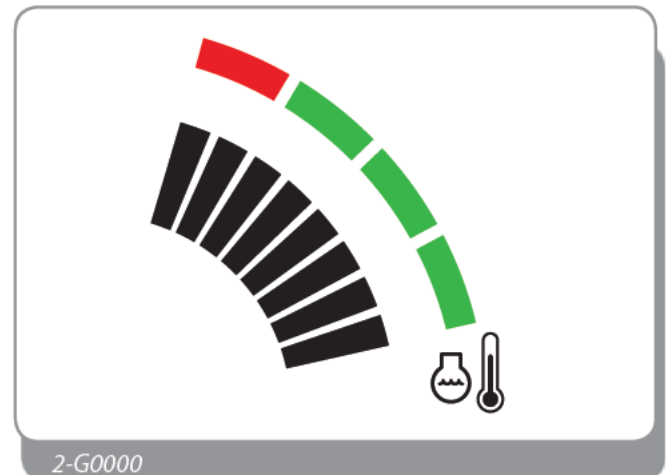

7.2.3 Tachometer

The instrument (Fig. 3-G0000) displays the machine speed in real time through four digits of which one decimal and the related unit of measurement (km/h).



7.2.4 Hourmeter

The instrument (Fig. 4-G0000) displays the total hours of use of the machine through the hourglass symbol and five digits.





7.2.5 Initial check

When turned on the panel lights up some indicator lights, the buzzer and all segments of the display for a time of 1.5 seconds. Below are listed all the lights on the instrument panel and their behavior during the check.

	Check		Check		Check		Check		Check		Check
No		Yes		Yes		Yes		Yes		Yes	
	Yes		Yes		Yes		No		Yes		Yes
Yes		Yes		Yes		No		Yes		Yes	
	Yes		Yes		No		No		Yes		No
Yes		Yes		No		No		Yes		No	

7.2.6 Acoustic signal

Some warning lights are particularly important for the life of the machine and its safe use has been coupled to the general alarm light and/or an intermittent acoustic signal.

		Description
		Danger of hydraulic system oil filter clogging
		Danger of engine oil failure
		Danger of parking brake insufficient pressure
		Reversed power steering controls

7.3 Gear selection lever

The lever on the left of the steering wheel (Fig. 6-G0000, pos.1) is used to change the direction and the speed of the transfers.

While holding the lever in an intermediate position ("N") the transmission is in neutral and the machine is partially braked.



- CAUTION

The FORWARD/BACKWARD gears engaging, is obtained after moving up the lever. This shifting protects the lever from accidental operation.

- Push the lever forward ("F" direction) to engage the forward gear.
- Move the lever towards yourself ("R" direction) to engage the reverse gear. When reverse gear is engaged an alarm sounds intermittently.



- WARNING

The movements of the lever are not active when:

- The handbrake is engaged
- The operator is not properly seated in the driver's seat



- CAUTION

Before reversing the direction of travel, minimize the motor speed and select the new direction.



- DANGER

It is dangerous to operate the forward/reverse gear selector lever with the engine at high rpm.



- WARNING

If the forward/reverse gear selector lever is moved in a position other from neutral with the parking brake engaged, the hydrostatic transmission does not operate.



- CAUTION

With the forward/reverse gear selection lever in position other than "N", the engine will not start.

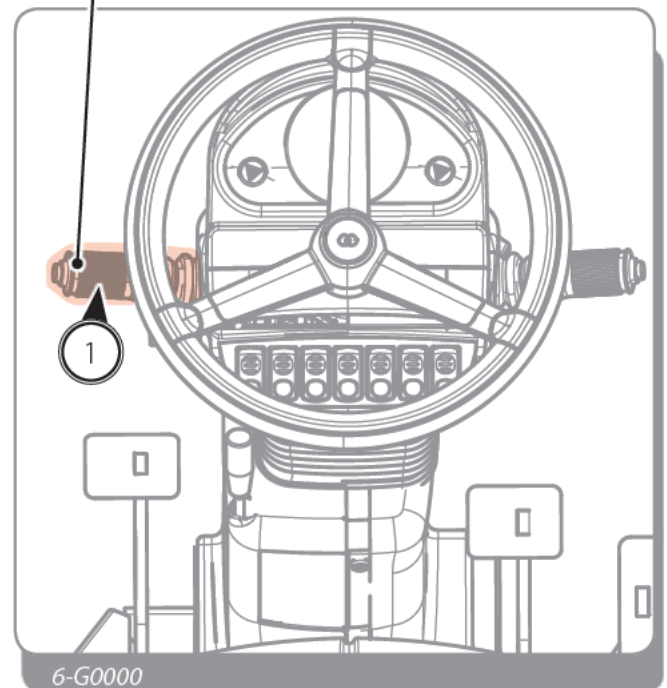
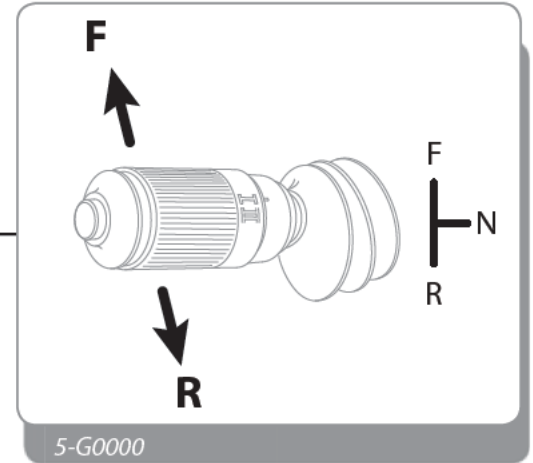

7.4 Multifunction lever

The multifunction lever (Fig. 7-G0000) contains several functions: direction indicators, horn, headlights turning on and window washers.

7.4.1 Direction indicators

- Move the lever towards yourself to indicate a curve to the right ("R").
- Push the lever forward to indicate a curve to the left ("L").

The indicators only work when the ignition switch is in the position of instrumentation on (Fig. 9-G0000, pos. 1).

An indicator light on the central instrument panel will activate the direction indicators.



- CAUTION

Push the multifunction lever in stand-by position after making the turn, return to the neutral position is not automatic.

7.4.2 Horn

Press the button on the end of the lever (Fig. 8-G0000, pos. 1) to activate the horn.

7.4.3 Window washer *



* The window washer is an optional accessory.

Press the intermediate button on the lever (Fig. 8-G0000, pos. 2) to activate the front window washer.

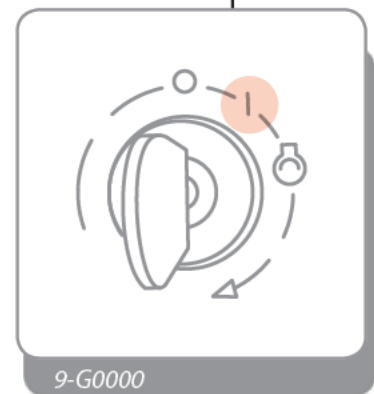
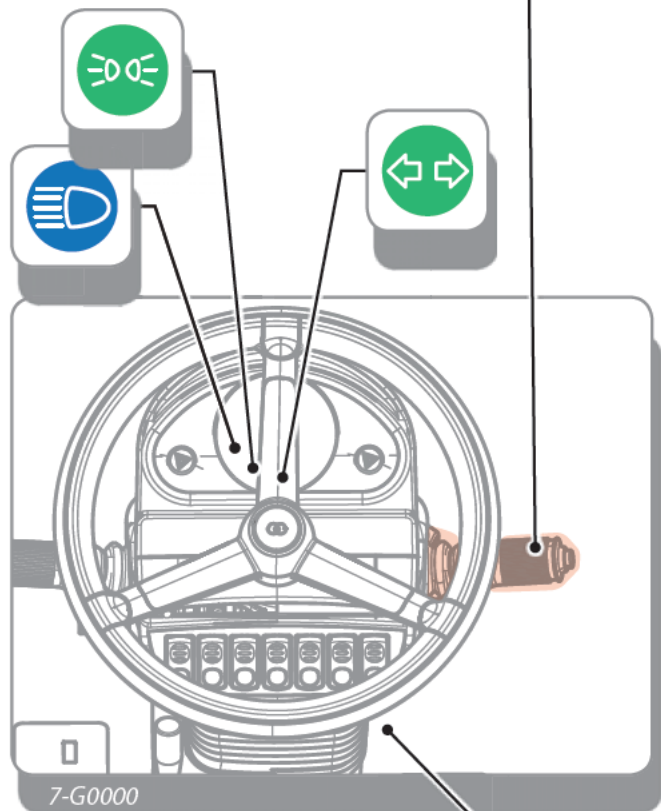
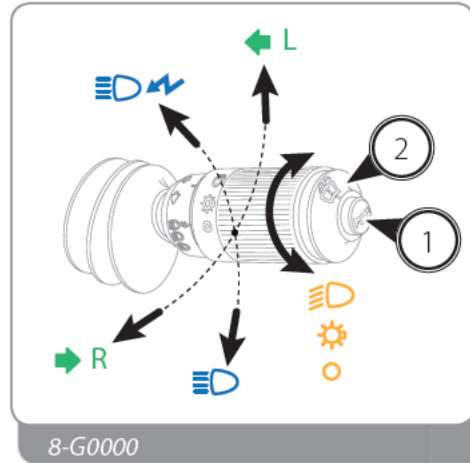

7.4.4 Switching on the headlights

To switch on the headlights, turn the multifunction lever (Fig. 10-G0000) until the segment matches the desired lighting mode.

The lever has three positions:

- Lights off
- Sidelights on
- Low beam lights on

An indicator light on the instrument panel will signal the activation of the sidelights and low beam lights.

7.4.5 Switching on the high beam lights

To turn on the high beams, turn the multifunction lever (Fig. 10-G0000) in low beam lights on, then lower the lever.

Return the lever multifunction lever to the neutral position to turn off the high beam lights.

To make individual flashes with the high beam lights, pull the multifunction lever towards the steering wheel.

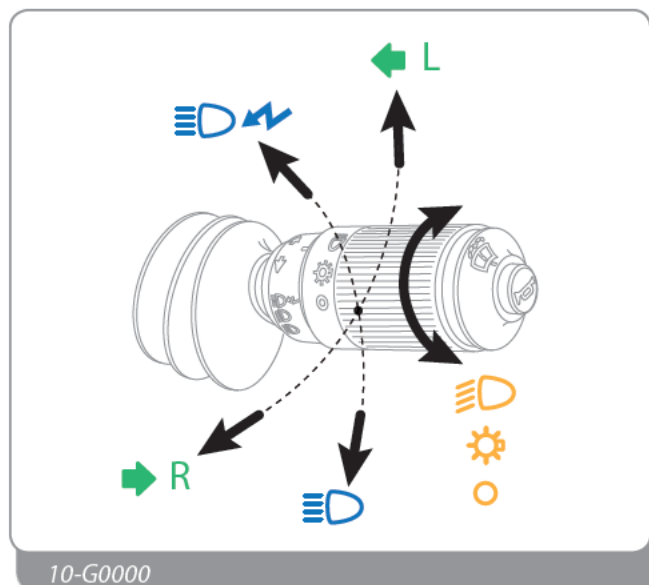

7.5 Pedals

7.5.1 Inching

The Inching pedal (Fig. 11-G0000, pos.1) operates directly on the hydrostatic transmission and allows slow and precise forward movements with high rpm engine.

With fully pressed Inching pedal, the transmission is temporarily stopped until the pedal is released.



- PROHIBITION

It is prohibited to sharply press the Inching pedal at high speeds or with engine at high rpm, the vehicle could brake suddenly or it may cause engine over-revving.

7.5.2 Brake

Press the brake pedal (Fig. 11-G0000pos.2) to slow down or stop the machine.

The brake pedal acts directly on the service brakes inside the axles.

When the brake pedal is pressed the stop lights of the rear lights go on. The lights remain in operation until the pedal is released.



Periodically check that both indicator lights are working correctly.



- PROHIBITION

Do not use the brake pedal for long periods to keep the machine braked or to move slowly forward.



In the case of restricted use of the pedal periodically check its proper operation. In case of problems contact the *DIECI* service center.

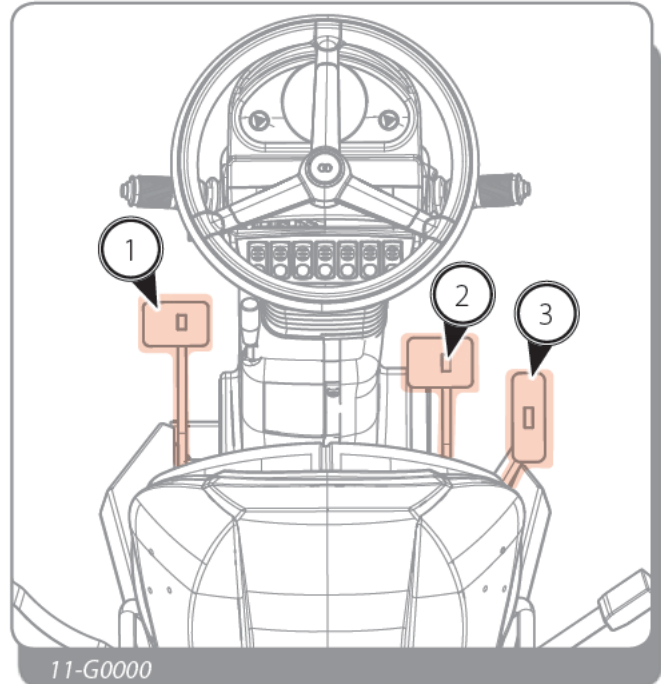

7.5.3 Accelerator

Press the accelerator pedal (Fig. 11-G0000, pos.3) to increase the engine rpm, release it to decrease it.

Increasing the number of engine revolutions, increases the drum movement and rotation speed.

7.6 Pressure gauge *

***The pressure gauge is present only on DP 7000 models**

The pressure gauge (Fig. 12-G0000) allows to control the servo brake pressure. In case of anomalies and faults, the pressure may drop.



- DANGER

The pressure should not drop below 18 bar.

In the case of low pressure (below 18 bar) stop the machine and contact an authorized Dieci dealer to eliminate the defect.



- PROHIBITION

It is absolutely forbidden to operate with servo brake accumulator pressure less than 18 bar.

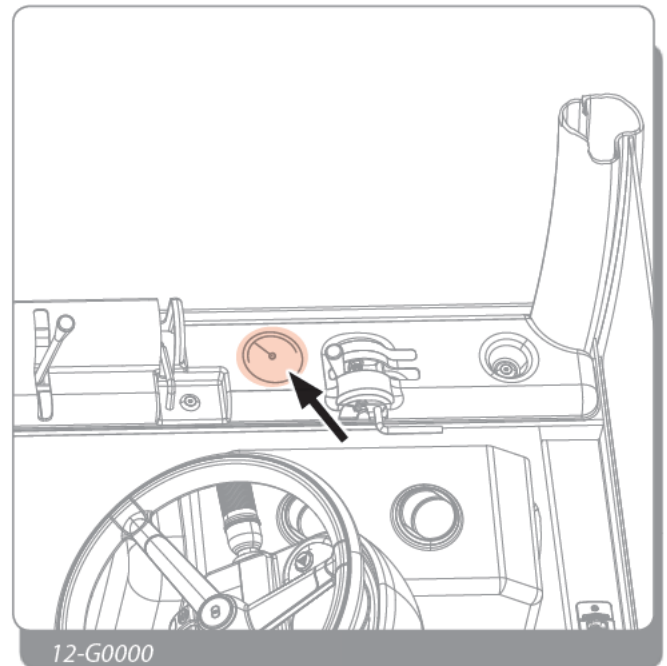

7.7 Driver's seat reversal pedal

The driver's seat reversal pedal (Fig. 13-G0000) is used to rotate the driver's seat 180° in order to facilitate the operations during the machine loading and unloading operations.



- CAUTION

For road travel is mandatory to keep the driving position facing towards the front of the machine.



- PROHIBITION

It is forbidden to work with the driving seat partially rotated.



For the correct driving seat reversing procedure refer to the "Safe working procedures" chapter.

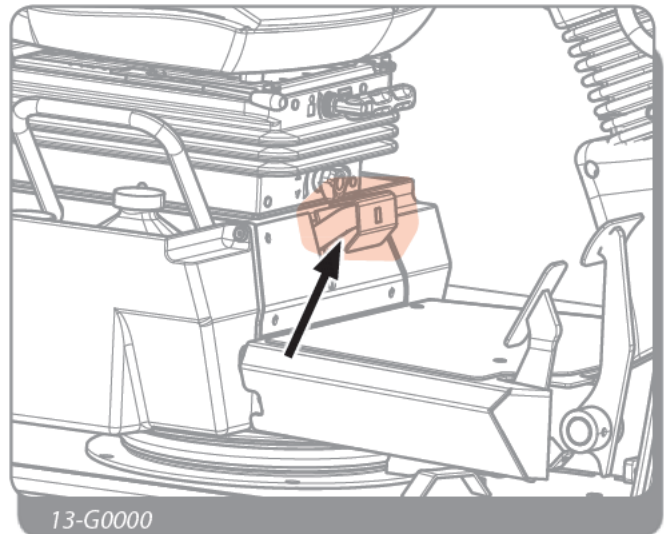

7.8 Power steering reversal lever

The power steering reversal lever (Fig. 14-G0000) is used to maintain the steering wheel direction of rotation conforming to the machine direction during the driver's seat reversal.



- WARNING

If the power steering reversal lever is not in the correct position in relation to the driver's seat position, an intermittent buzzer starts operating and the related light on the instrument panel turns on.



- CAUTION

Operate the power steering reversal lever with reverse parking brake lever engaged and gear selector lever in "N" (neutral).



For the correct driving seat reversing procedure refer to the "Safe working procedures" chapter.

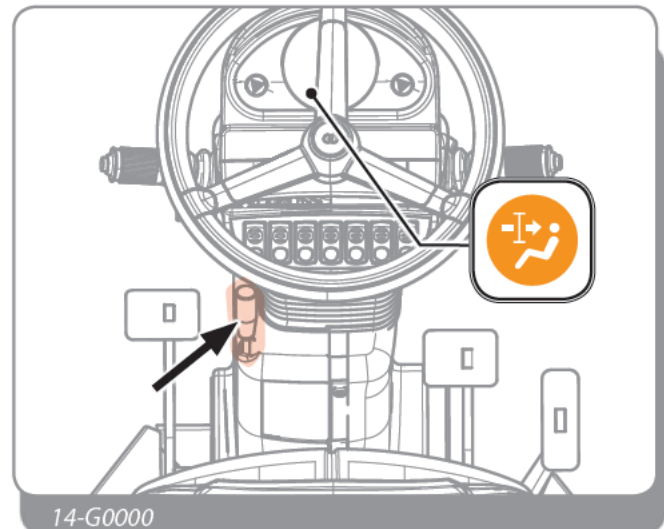

- PROHIBITION

It is absolutely forbidden to use the transverse steering modes when the driver's seat is facing the back of the machine.



7.9 Emergency lights switch

Press the emergency lights switch (Fig. 15-G0000, pos.1) to turn on all four direction indicators intermittently.

Press again the switch to turn off the function.

7.10 Rotating light switch

Press the rotating light switch (Fig. 15-G0000, pos.2) to turn on the rotating light.

Press again the switch to turn off the function.



- WARNING

Always work with the rotating light in operation.



- CAUTION

It is compulsory to use the rotating light when driving on the road, even in the daytime.

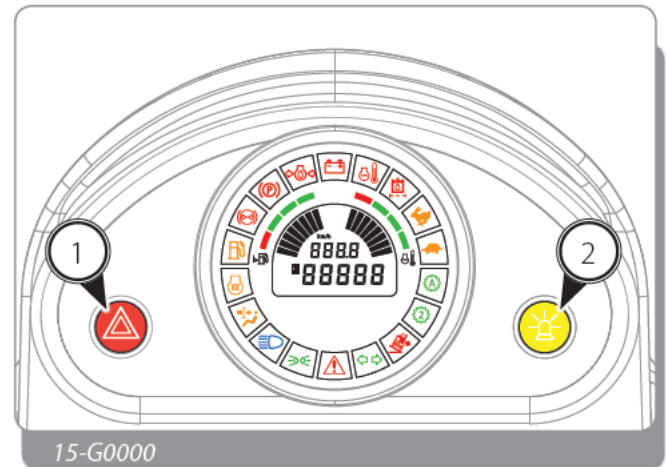

7.11 Front window wiper

Press the switch (Fig. 16-G0000, pos.1) to operate the front window wiper.

The function will remain in active until it is disabled from the switch.



Replace the wiper blades when they are worn to prevent poor visibility. Worn blades can scratch the glass.

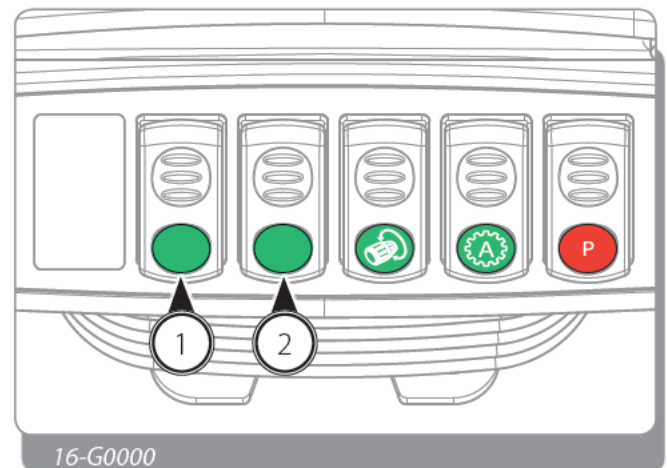

7.12 Rear window wiper

Press the switch (Fig. 16-G0000, pos.2) to operate the rear window wiper.

The function will remain in active until it is disabled from the switch.



Replace the wiper blades when they are worn to prevent poor visibility. Worn blades can scratch the glass.

7.13 Slow/fast gear shift button

The gear shift button (Fig. 17-G0000) is used to change the speed of the machine movements.

- Press the button from the "A" side to engage the slow gear
- Press the button from the "B" side to engage the fast gear

To change gears from slow to fast or vice versa, it is necessary to:

- Stop the machine
- Fully press the inching pedal and the brake pedal
- Press the gear change button on the side corresponding to the desired mode
- Once the light corresponding to the selected gear on the instrument panel turns on, gradually release the Inching pedal
- Accelerate gradually to allow the gear to engage

With correctly engaged gear, the following indicator lights on the instrument panel will be lit:

- The indicator light corresponding to the gear (fast or slow) (Fig. 18-G0000, pos.1)
- The correctly engaged gear indicator light (Fig. 18-G0000, pos.2)



- CAUTION

In the event that, after selecting the gear (slow or fast), the correctly engaged gear indicator light remains off, it means that the gear is selected, but not engaged. Accelerate slowly to allow the gear to engage properly.

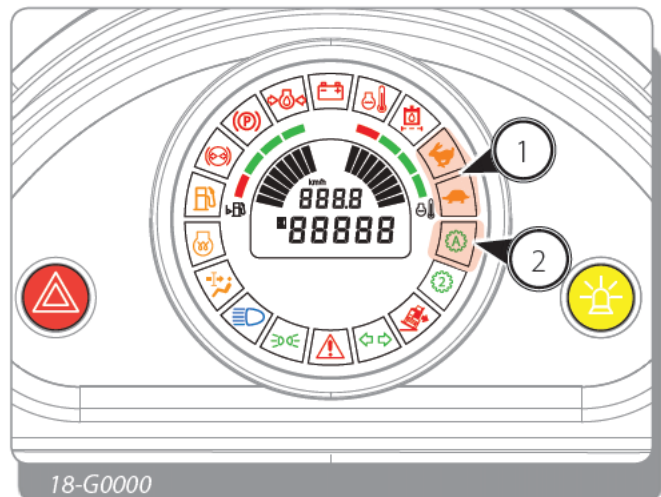
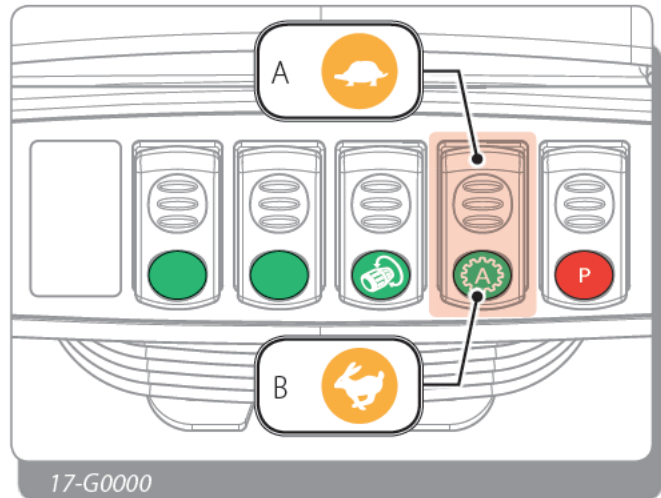

7.14 Parking brake switch

The parking brake must be engaged every time the operator leaves the machine, with stopped or running engine, during stops even if only temporarily.

The parking brake engages automatically when the engine is stopped.

Press the switch (Fig. 19-G0000) to engage the parking brake. The indicator light on the switch and the corresponding indicator light on the instrument panel (Fig. 20-G0000) indicate that the parking brake is in operation.

With the parking brake engaged, the machine cannot move; the hydrostatic transmission is switched off.



To verify the efficiency of the parking brake contact a DIECI authorized workshop.



- DANGER

In case of failure of the parking brake do not use the machine.



- DANGER

Unauthorized modification of axle ratios, the weight of the machine, the size of the wheels and tires can affect the efficiency of the parking brake.



- PROHIBITION

It is absolutely forbidden to use the parking brake while driving; do not use the parking brake to slow down and stop the vehicle.

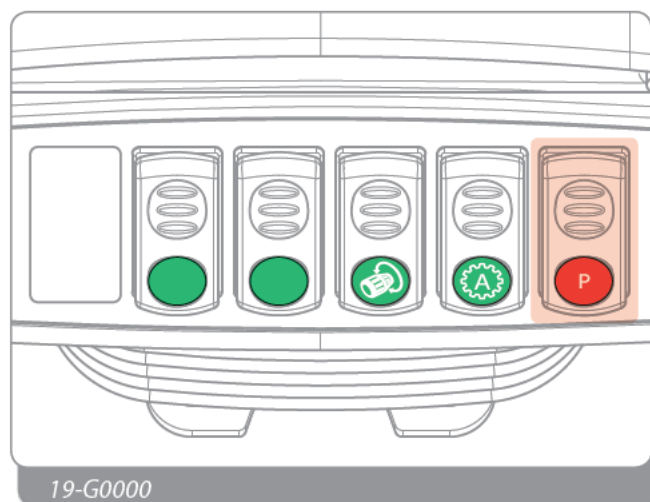

19-G0000

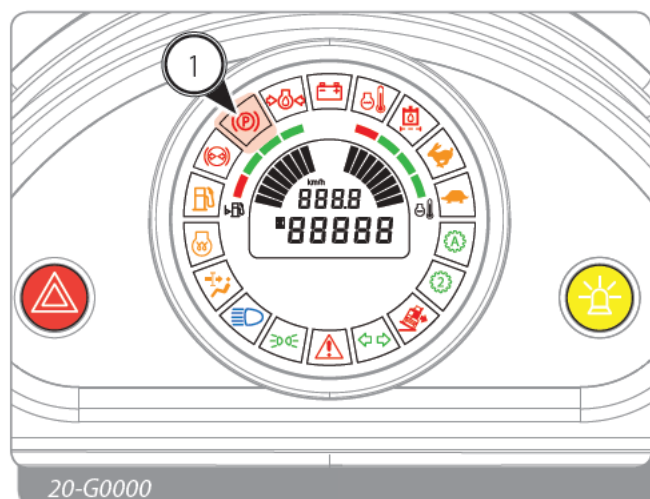

20-G0000

7.15 Steering mode control lever

The steering selector (Fig. 21-G0000, pos.1) is used to change the wheels steering mode:

A - Four-steering wheels

This type of steering is made with all four wheels, so as to have the smallest turning radius possible.

B - Front-steering wheels

This type of steering is made with only the front wheels.

C - Transverse

This type of steering allows a transverse or crab steering, so as to have a lateral displacement of the machine.



- PROHIBITION

Do not select the steering mode while the vehicle is moving.



- CAUTION

For road travel is mandatory to select the four-wheel steering mode (Fig. 21-G0000, pos.A) and lock the selector with the dedicated fastener (Fig. 21-G0000, pos.2).



- WARNING

Before selecting a new type of steering, align the wheels.



- DANGER

When the transverse steering is selected, always operate at low speed.



- PROHIBITION

It is absolutely forbidden to use the transverse steering modes when the driver's seat is facing the back of the machine.

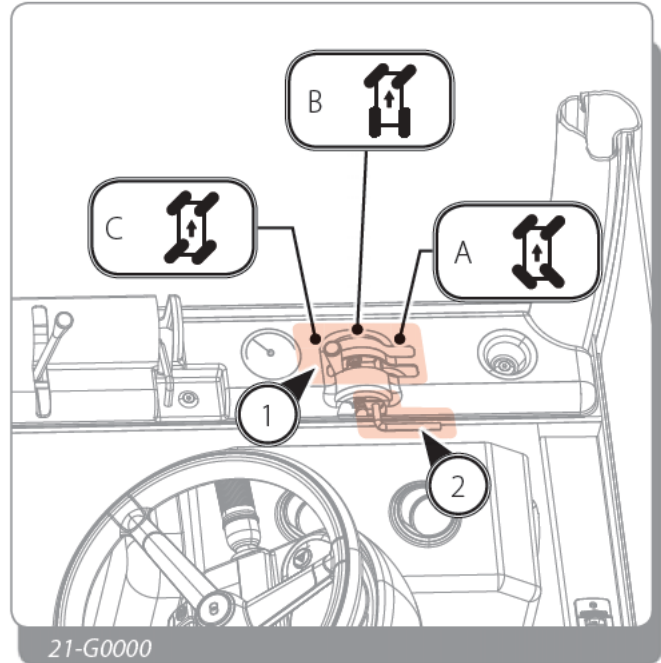

7.15.1 Wheels alignment

During normal use of the machine, frequently changing the steering modes, it is possible that the wheels are no longer perfectly aligned with each other.



- WARNING

Perform the wheel alignment periodically (every 8-10 hours) depending on the continuous use of the machine.

To perform a proper wheel alignment, perform the following steps:

1. Stop the machine on a level ground.
2. With the A steering mode
3. Turn the steering wheel until the rear wheels are aligned to the machine.
4. Select the B steering mode
5. Turn the steering wheel until the front wheels are aligned to the machine.
6. Try to move slowly for a few meters to verify that the machine travels properly in a straight line.



- CAUTION

If at the end of the alignment the machine still does not proceed in a straight line, repeat the wheels alignment.

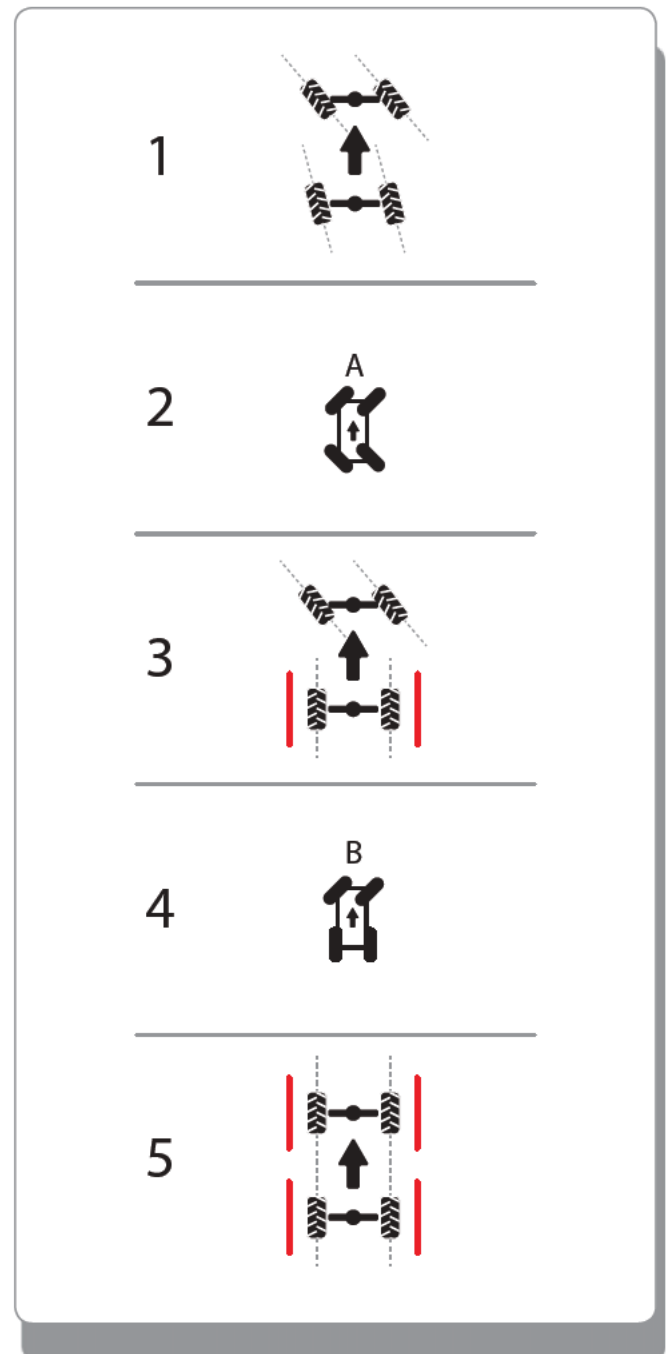

7.16 Hand throttle control lever

The lever (Fig. 22-G0000) located on the left of the operator, has the same function of the accelerator pedal. Pulling the lever upwards accelerates the engine rpm; bringing it down decelerates to a minimum.



- CAUTION

Use the hand throttle control lever only if sitting at the driver's seat.



- DANGER

Do not move the machine when using the hand throttle; this command can only be operated with the transmission in neutral and the parking brake engaged.



- PROHIBITION

IT IS STRICTLY FORBIDDEN TO USE THE HAND THROTTLE CONTROL LEVER WHILE THE MACHINE IS TRAVELLING.

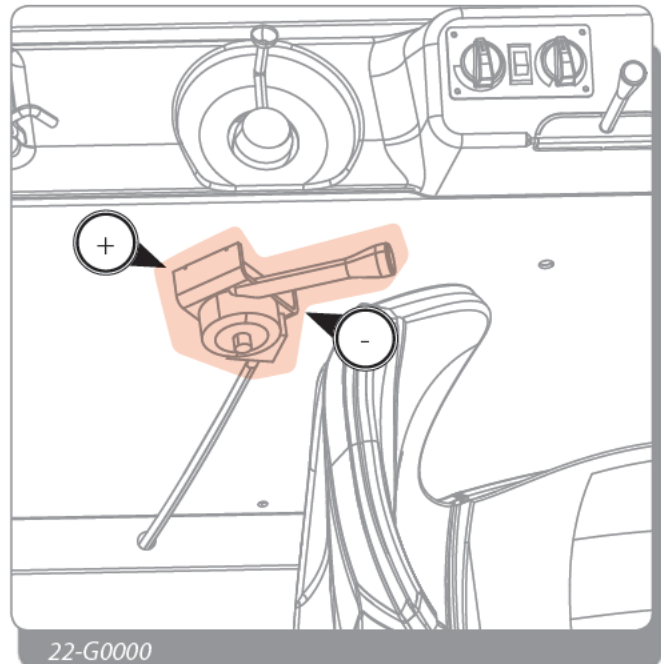

7.17 Dump body lifting control lever



- DANGER

Before moving the dump body, make sure that there are no personnel or obstacles within the operating range of the machine.

To raise and lower the dump body, move the corresponding lever (Fig.pos.3):

- Push the lever to the "A" side to lower the dump body, returning it in transport conditions
- Pull the lever to the "B" side to lift the dump body, facilitating the discharge



- WARNING

Releasing the lever, this will return to the central rest position and the movement will stop; the body dump will then stop in the position reached



- CAUTION

The dump body must be fully lowered when the machine is traveling on the road.

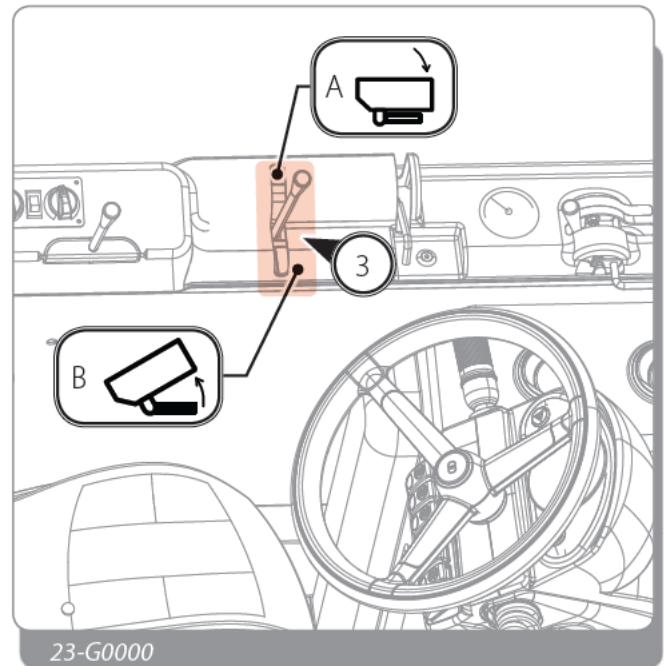

23-G0000

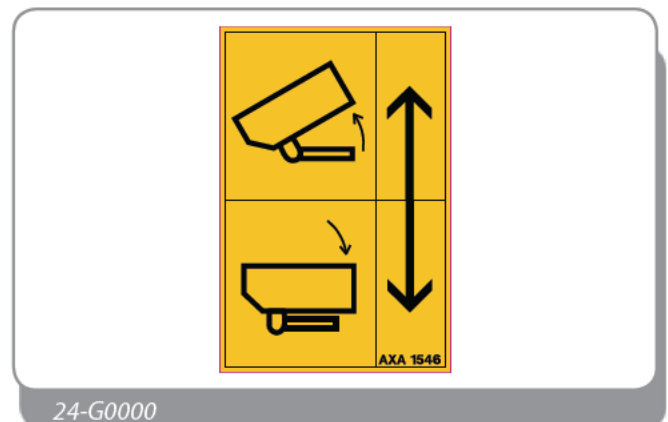

24-G0000

7.18 Door *



* The door is an optional accessory.

The door (Fig. 25-G0200 external view, Fig. 26-G0200 internal view) consists of the following components:

1	Main leaf
2	Secondary leaf
3	External handle
4	Openable glass
5	Open glass lock
6	Open door lock
7	Closed glass lock
8	Internal handle
9	Secondary leaf opening handle
10	Glass unlock knob
11	Open door unlock button

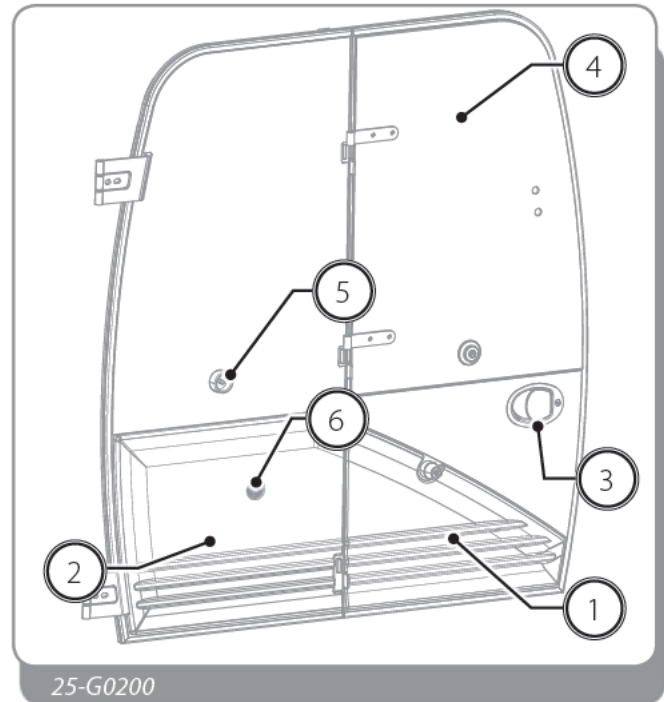

7.18.1 Main leaf opening/closing

To open the door from the outside:

- open the door using the ignition key
- pull the handle (Fig. 25-G0200, pos.3) outwards

To open the door from inside the cab:

- Press the internal handle (Fig. 26-G0200, pos.8)
- Push the door outward.

To release the main leaf:

- Press the release button (Fig. 26-G0200, pos.11)
- Turn the glass release knob (Fig. 26-G0200, pos.10)
- Close the door.

7.18.2 Door glass opening/closing

To open the door glass:

- Turn the handle downwards (Fig. 26-G0200, pos.7)
- open the glass until it locks (Fig. 25-G0200, pos.5) in the related housing on the secondary leaf.

To release and re-close the glass:

- Turn the glass release knob (Fig. 26-G0200, pos.10)
- Re-close the glass
- Fasten the handle (Fig. 26-G0200, pos.7).

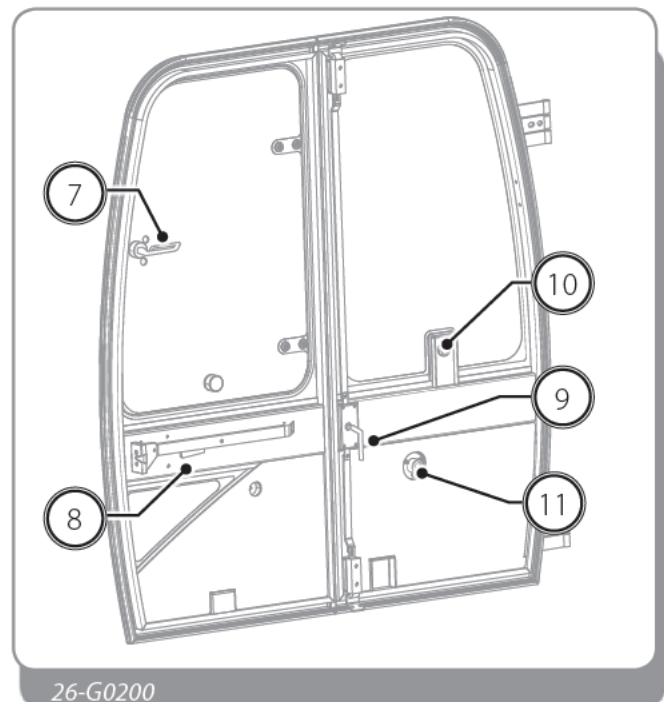

7.19 Glass on engine side *

 * The glass on the engine side is an optional accessory.

To open the glass on the engine side (Fig. 28-G0200) it is necessary to press one of the handles located at the glass sides (Fig. 28-G0200, pos. 1 and 2) and drag on the side.

To close the glass drag the handle until the glass locks at the end of the stroke.

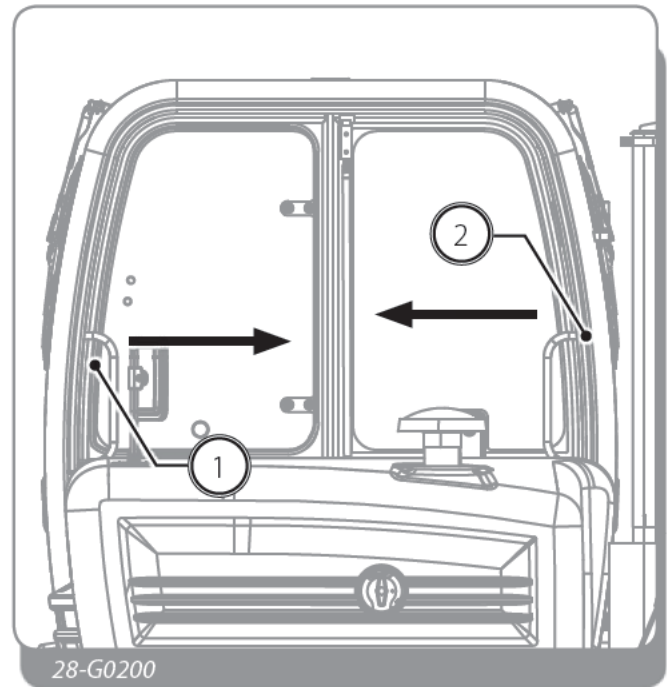

7.20 Heating *

 * Heating is an optional accessory.

The heating controls are located on the left instrument panel (Fig. 11-G0000):

Use the ventilation knob (Fig. 11-G0000, pos.1) to turn on and set the desired ventilation speed:

- **Position 0:** Off
- **Position 1:** Fans low speed
- **Position 2:** Fans medium speed
- **Position 3:** Fans fast speed

Use the temperature knob (Fig. 11-G0000, pos.2) to set the desired temperature:

- **Hi:** Warm
- **Lo:** Cold

7.21 Air Conditioning (A/C) *

 * Air conditioning is an optional accessory.

To turn on the air conditioning press the switch (Fig. 11-G0000, pos.3) on the "1" side and turn the temperature knob to **Lo**.

To turn off the air conditioning press the switch on the "0" side.

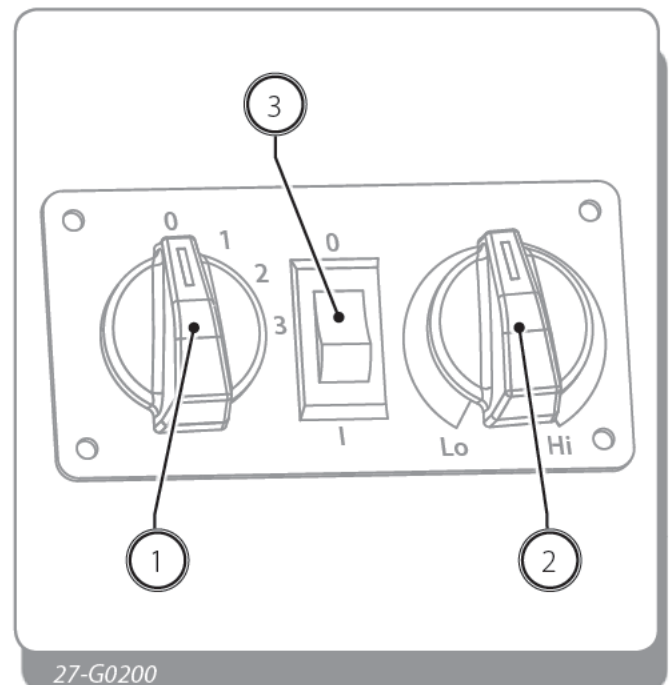

8 DESCRIPTION OF COMPONENTS

8.1 Tyres



ATTENTION

Upon receiving the vehicle, check the air pressure of the tyres.

- Periodically check the air pressure of the tyres. The pressure should be checked when the tyres are cold.
- Tyre pressure must always be kept at the required levels.
- Check the size of the installed tyres and the serial number to ensure they are inflated to the correct pressure.



DANGER

Tyres that are torn or are excessively worn should be replaced immediately.

- Before each use, make sure that the sides of the tyres are not damaged.
- Keep all oils, grease and corrosive liquids away from the tyres to prevent any damage to the rubber.
- To ensure maximum efficiency do not use tyres with more than 80% tread wear.



ATTENTION

Inflating or working on tyres can be dangerous.

- See specialised personnel for intervening on or installing tyres.
- In any case, to prevent serious or mortal injury, follow the safety precautions described below.
 - The vehicle tyres are very heavy. Handle with care and ensure that, once stored, they cannot fall and injure anyone.
 - Never attempt to repair a tyre on a public road or motorway.
 - Make sure that the car jack is positioned on a solid, flat surface.
 - Make sure that the jack is suitable to support the weight of the vehicle.
 - Use jack tripods or other locking devices suitable for supporting the vehicle while repairing tyres.
 - Never place any part of your body under the vehicle.
 - Never start up the vehicle while it is on the jack.
 - Never hit a tyre or rim with a hammer.
 - Make sure that the rim is clean, and that there is no rust or damage. Do not weld, braze, repair or use a damaged rim in any way.
 - Do not re-inflate a tyre that has travelled partially or very deflated until it has been properly inspected by a qualified technician.
 - Do not inflate a tyre unless the rim is mounted on the vehicle or secured so that it will not move in the event that the tyre or rim should suddenly rupture.
 - Never inflate tyres in excess of the pressure indicated by **DIECI**. If the heel does not settle on the rim when this pressure level is reached, deflate the tyre and lubricate with a soapy water solution, then inflate again. Do not use oil or grease. Inflation exceeding the permitted level on unsettled heels can cause heel or rim breakage with an explosive force that can cause serious injury.
 - After having remounted the wheel, tighten the nuts between the wheel and axles. Check the torque of the nuts every day until it has stabilised.

**ATTENTION**

When mounting a new or repaired tyre, use an adapter for the spring valve with a distance manometer which allows the operator to keep away from the tyre during inflation. Use a safety fence system.

**- FORBIDDEN**

Do not mount inflated tyres with polyurethane foam unless authorised by the manufacturer.

8.1.1 *Tightening the wheel nuts*



Tighten the nuts in accordance with the schedule provided in the maintenance table

Refer to the relative table for the correct torque

Always tighten the nuts positioned opposite each other, not consecutively.

After having remounted the wheel, tighten the nuts between the wheel and axles. Check the torque of the nuts every day until it has stabilised.

**ATTENTION**

The number of axle studs must correspond to the number of tightened nuts. Therefore all nuts must be mounted on each tyre; otherwise the vehicle will not operate.

If a tyre is replaced, the vehicle or the lifted side can be set back on the ground only with tyres mounted and properly tightened.

**ATTENTION**

The nuts must first be tightened with the vehicle, or parts of it, lifted from the ground, and then with the vehicle on the ground.

Only use original **DIECI** nuts to tighten the wheels. Should even just a single nut be lost, contact the **DIECI** service centre.

8.1.2 *Urethane foam filled tyres*



Urethane foam filled tyres is an optional feature.

**ATTENTION**

The maximum allowed speed with the tyres filled with urethane foam is 20 km/h (12.4 mph).

**- FORBIDDEN**

It is forbidden to circulate on public roads when the tyres are filled with urethane foam.



8.1.3 Rim size, tires and inflation pressure table

	Tire dimensions	Characteristics	Brand	Inflation pressure			Rim size	Drawing
				bar	MPa	psi		
L3500 (LH682)								
Standard	12.5-18	16 PR	MITAS	5.0	0.50	72	11.00 x 18	MPT-04 TL
Alternative	12.5-18	16 PR	BKT	5.0	0.50	72	11.00 x 18	MP567 TL
L4700 (LH683)								
Standard	405/70-20 (16/70-20)	14 PR	MITAS	4.2	0.42	60	13.00 x 20	MPT-04 TL
Alternative	405/70-20 (16/70-20)	14 PR	MITAS	4.2	0.42	60	13.00 x 20	MPT-01 TL
Alternative	405/70-20 (16/70-20)	14 PR	BKT	4.5	0.45	65	13.00 x 20	MP 567 TL
Alternative	405/70 R20 (16/70 R20)	152J	MITAS	6.0	0.60	87	13.00 x 20	MPT-21 TL
L7000 (D648)								
Standard	405/70 R24 (16/70 R24)	152J	MITAS	4.00	0.40	58	13.00 x 20	MPT-21 TL

8.2 Fuel

Before handling fuel and filling the tank, comply with the following regulations:



- FORBIDDEN

Never add different types of fuel such as petrol or alcohol to diesel.



- FORBIDDEN

It is forbidden to refuel while the engine is running

- Clean the area around the fuel cap. Refill the fuel tank at the end of every day to reduce condensation when the vehicle is at rest.
- Water and sediments must be removed before they reach the engine.
- Do not use antifreeze to remove water from diesel fuel.
- Do not rely on a filter to remove water from diesel fuel.
- Never leave the tank without a cap and always lock it. Should you lose the original cap, replace it with an original spare. Not just any cap is suitable.
- Keep the fuel pump gun under control while filling the tank.



- IT IS FORBIDDEN TO SMOKE AND HAVE OPEN FLAMES

It is forbidden to smoke when refuelling

- Do not inspect the tank with a flame.
- Do not fill up the tank completely. Leave room for expansion and immediately clean any spillage.
- In the event of fuel leaks due to breakage, stop the leak as quickly as possible, do not use the vehicle and contact DIECI customer service.



- DANGER HARMFUL VAPOURS

Inhale diesel fumes for the least time possible as they are dangerous carcinogens for your health

8.2.1 Specifications for recommended fuel



To achieve good performance, see the engine manual of the vehicle to know the best features.

8.2.2 *Cleaning and storing fuel*

It is important for the fuel to be kept clean.

The advice provided below will help maintain fuel quality.

- Never use zinc-coated containers.
- Never clean the inside of containers or power supply system components with cloths that may leave deposits.
- The cistern capacity (figure at the side) must allow intervals between refuelling not to be too long. A capacity of 3,000 litres is sufficient for an average sized company.
- The storage cistern must be covered and placed on a support that is high enough to allow refuelling by means of gravity. A large basin must be placed under the cistern in case of fuel leakage. The cistern must have an opening large enough to allow someone to access it for cleaning purposes.
- The delivery tap must be larger at the bottom in order to trap any deposits; it must also be equipped with a removable filter. The cistern should be tilted 40 mm per metre towards the sedimentation drain plug.
- The fuel barrels (figure at the side) must be covered when stored to prevent water infiltration. The barrels should be slightly tilted slightly, so that any water will run to the upper rim. The fuel barrels should not be stored for too long before being used.
- If the barrels are kept outside, their caps must be tightly closed to prevent water from seeping in.
- After refuelling the storage cisterns or barrels, it is recommended to allow the fuel to set for at least two hours, thereby allowing any sediment of water and impurities to be deposited before the fuel is used.

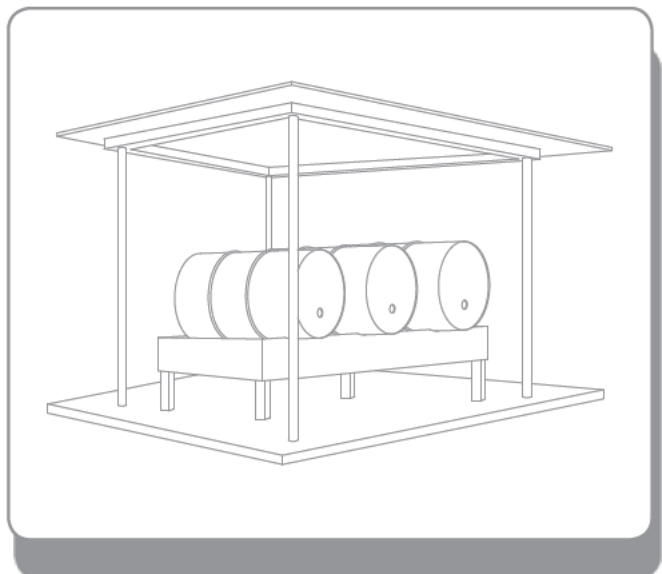
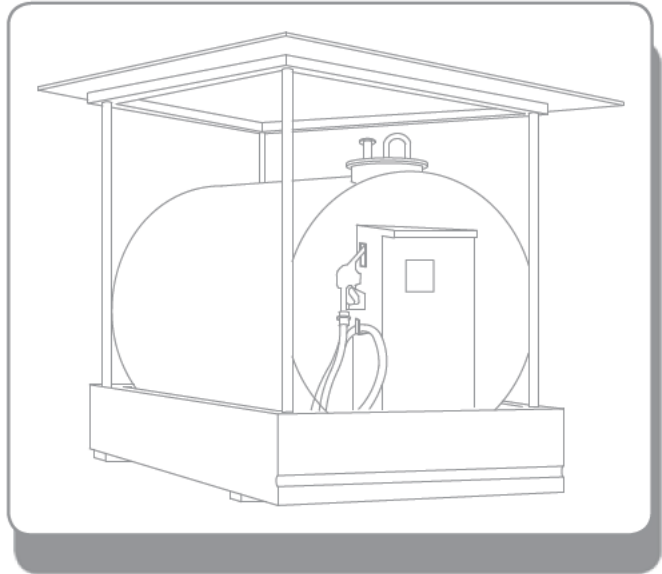

8.2.4 Refueling

When refueling (Fig. 1-H02-11) it is necessary to:

- Park the vehicle and turn off the engine
- Go to the rear of the machine and open the filler to access the fuel cap
- Open the fuel cap
- Refuel
- Close the fuel cap
- Close the filler

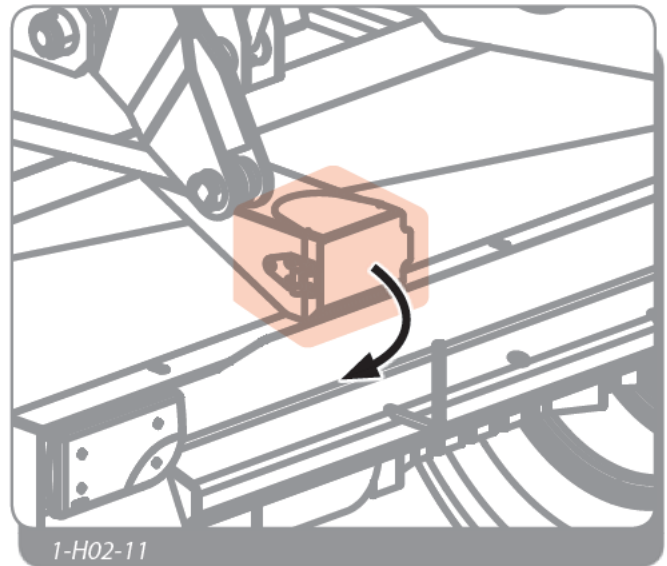

8.2.3 Fuel tank: Cleaning

With the machine in the maintenance position:

- Place a suitable container under the fuel tank.
- Remove the cap from under the tank (Fig. 2-H02-11) and drain the fuel to remove impurities present in the tank.
- Put back the cap and fill with clean fuel.

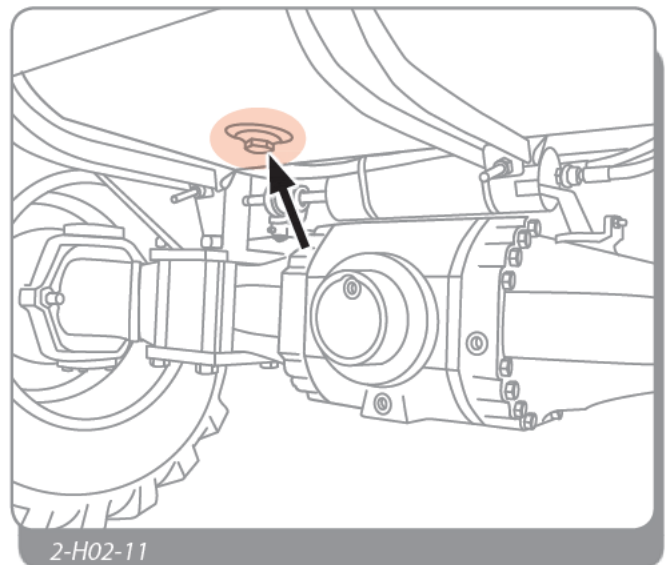



8.3 Engine



ATTENTION

The use and maintenance manual of the FPT engine is an integral part of the documentation supplied with the vehicle



Consult the engine manual or contact an authorized workshop for maintenance.

It is recommended to carefully read the information in the instruction manual and comply with it: in this way accidents will be prevented, the manufacturer's warranty will apply and you will always have an efficient engine, ready for use.



8.4 Battery



- DANGER: BATTERY EXPLOSION

To prevent the batteries from exploding:

- Keep sparks, open flames and cigarettes away from the upper part of the batteries as the gas produced by the latter is highly flammable.
- Do not recharge damaged batteries.
- Do not charge a hot battery.



- DANGER: HARMFUL SUBSTANCES

Batteries contain highly polluting substances that must not be released into the environment. Batteries that are dead, old, damaged, etc. must be disposed of properly.



- DANGER: CORROSIVE SUBSTANCES

The battery contains sulphuric acid electrolyte, which is a corrosive substance which must be handled with caution as it can cause poisoning and serious burns.

Keep out of the reach of children.

Avoid contact with skin and eyes.



- ATTENTION

Wear protective clothing, gloves and goggles. Should contact be made with the eyes and skin, rinse immediately with plenty of water and consult a doctor. If swallowed, immediately contact a doctor.

- Do not overturn or tilt the battery as acid could come out.
- Recharge the battery in a well-ventilated place and always disconnect the power supply before disconnecting the terminals.
- Always use a voltmeter or a densimeter to check the battery charge. Should you need to check the electrolyte level, use a torch and never an open flame.
- Never place a metal object between the terminals to check the battery charge.
- DO NOT create sparks with the wire clamps while recharging the battery or while starting the vehicle engine with an auxiliary battery.
- Make sure the caps and vent covers are fitted correctly and tightened securely.
- Clean the upper part of the battery, make sure the terminals are tightened securely and cover them with a thin layer of Vaseline.
- Should the battery freeze, place it in a warm place and allow it to thaw. Do not use or recharge it; danger of explosion.
- In normal conditions, the battery is kept charged by the vehicle alternator. Should the battery run out completely as a result of prolonged inactivity or because it is at the end of its life, the alternator can no longer "regenerate" it. The battery must be replaced and recharged by means of a special battery charging instrument.



- ATTENTION

Before performing any maintenance on the vehicle, disconnect power from the electric circuits by pressing the battery isolator switch



8.4.1 *Low maintenance batteries*

Low maintenance batteries have been designed to avoid frequent routine maintenance interventions. Check the level of electrolyte if discharged. Contact the supplier or the manufacturer for the technical specifications.

8.4.2 *"Zero maintenance" batteries*

These are batteries that do require maintenance.

The battery must be replaced once it is completely discharged. Contact the supplier or the manufacturer for the technical specifications.



- FORBIDDEN

Do not perform maintenance or recovery operations on "zero maintenance" batteries.

8.4.3 Battery: Recharging the battery

- A battery is fully charged if, at a constant temperature, the electrolyte density and the tension measured at the poles does not increase within 2 hours.
- The efficiency of each recharge depends on the general conditions of the battery itself. An old battery will not be able to obtain the same life and efficiency as a new battery after recharging.
- The simplest recharging method is to charge at constant power.
- Once charging is complete, the battery charger voltage increases and creates gasification. We recommend using simple battery chargers with minimum current control and a switch-off timer.
- If the battery has a low level of electrolyte, top-up to the minimum level (just above the plate limit) and then charge. Fill up to the maximum level once charging is complete (to prevent spills).
- Overcharging must be avoided because:
 - It is a loss of energy that causes water dissociation.
 - It produces a loss of active mass due to electrode deterioration.
 - It generates the risk of explosion.
- If sulphuric batteries are recharged with no voltage limit, they will boil and heat, thereby generating the risk of explosion.
- Old batteries (sulphuric in most cases) must be charged with caution. An increase in temperature is possible even with 13.8 Volts.

Follow the instructions below to charge the battery:

1. Disconnect the wires of the vehicle from the battery to protect its electrical system.
2. Place the battery at a safe distance from the vehicle.
3. Remove the caps, if possible.
4. When possible, check the electrolyte level.
5. Clean the poles.
6. Make sure the area is sufficiently ventilated.
7. Limit the charging current to a maximum of 1/10 of the battery capacity (Ah).
8. Connect the battery to the battery charger.
9. Connect the battery charger to the mains.
10. Switch the battery charger on.
11. Battery temperature must not exceed 55°C.
12. Switch the battery charger off when finished.
13. Disconnect the battery charger from the mains.
14. Disconnect the battery from the battery charger.
15. When possible, check the electrolyte level.
16. Refit the caps.



8.4.4 Battery cut-off switch



- CAUTION

Use this switch only when the engine is stopped.

The battery cut-off switch "1" (Fig. 1-H5111) allows the operator to isolate the battery from the electrical circuit in case of emergency or during maintenance operations.

To isolate the battery:

1. Turn off the engine.
2. Turn the ignition key to position "0".
3. Turn the battery cut-off switch counterclockwise to the off position.

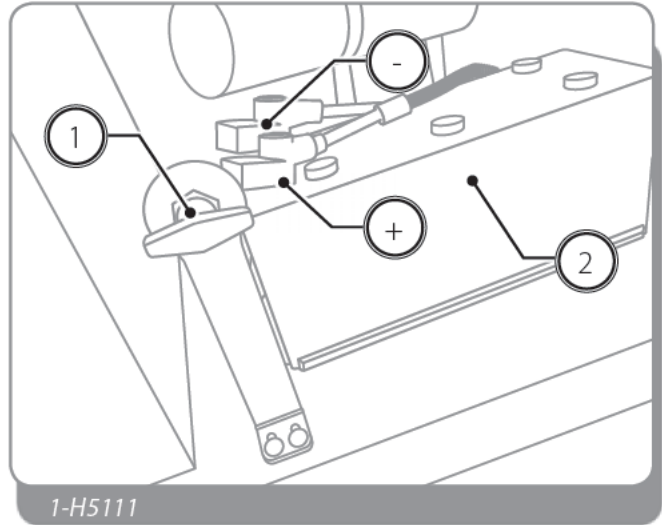

8.4.5 Battery: Replacement

The machine is equipped with a battery located in the engine compartment "2" (Fig. 1-H5111).

Before removing the battery disconnect it from the electrical circuit through the appropriate battery cut-off switch, following the instructions given in the relevant chapter.

To remove the battery:

1. Place the machine in the service position as described in the "Setting the machine for maintenance" section
2. Open the engine hood and fasten it with the support rod "1" (Fig. 2-H5111)
3. Disconnect the NEGATIVE cable (black) from the battery
4. Disconnect the POSITIVE cable (red) from the battery
5. Remove the battery from the machine
6. Place the new battery
7. Connect the POSITIVE (red) cable to the battery
8. Connect the NEGATIVE (black) cable to the battery
9. Reactivate the battery cut-off switch

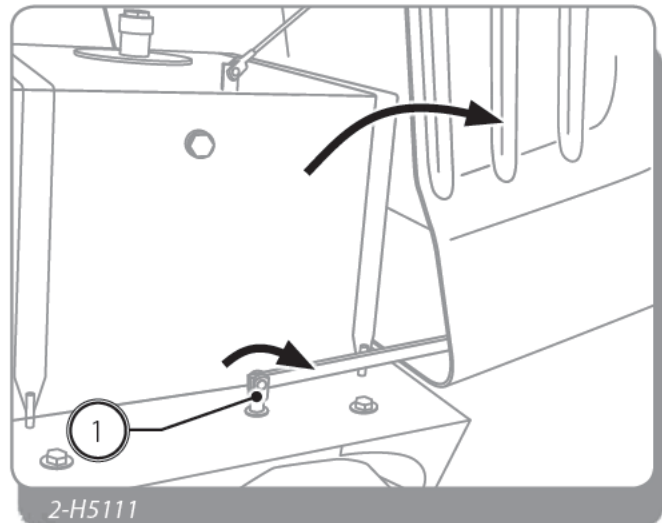

8.5 Lighting

Vehicle lighting must always be efficient and functioning properly. Its functionality must be checked daily. Replace any damaged part of the lighting body immediately. Replace a burnt light bulb immediately.



Refer to the "Maintenance" chapter before performing any maintenance or adjustments.



- NOTE

The bulbs are very fragile. Handle them with care.

The dipped beam bulbs must not be handled with bare hands.

8.5.1 Front light

In the front headlight (Fig. 1-H5301) it is composed of:

	Description	Type
1	Direction indicator	21 W
2	Front side light	4 W
3	Dipped lights/high beams	60/55 W H4

To access the bulbs:

1. Set the vehicle in the maintenance position.
2. Act on the battery isolator switch to disconnect the supply to the electrical system.
3. Remove the power connector of the rear light.
4. Remove the front part of the light by loosening its screws located in the rear cap.

Close the light by carrying out these steps in inverse order, being careful to position the sealing gasket correctly.

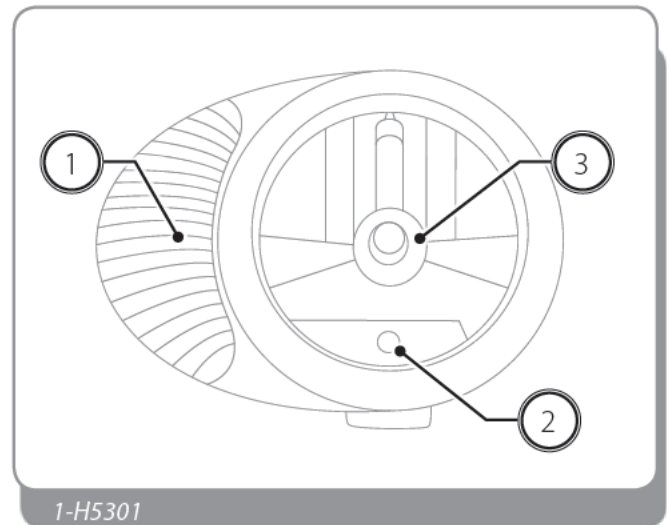

Replacing a direction indicator bulb

- Press the upper part of the bulb (Fig. 2-H5301).
- Turn the bulb while pressing it down to release it from the lock.
- Carry out the same steps to insert the new bulb.

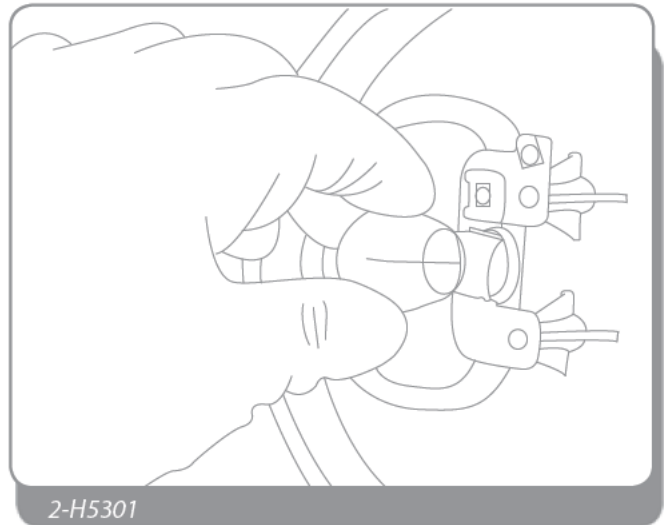

Replacing a side light bulb

- Grasp the rear part where the electrical connections are located (Fig. 3-H5301).
- Turn and pull the rear part towards you.
- Remove the support and press the upper part of the bulb.
- Turn the bulb while pressing it down to release it from the lock.
- Carry out the same steps to insert the new bulb. Reinsert the support inside its housing.

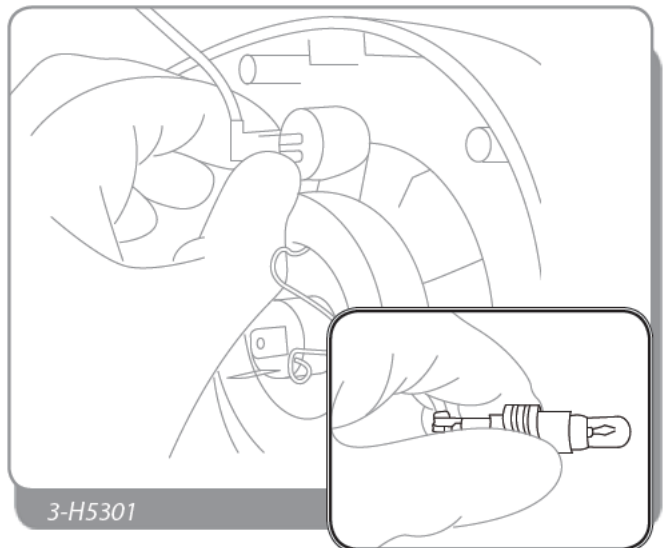

Replacing a dipped light/high beam bulb

- Remove the electrical connector by pulling it towards you.
- Raise the locking tabs (Fig. 4-H5301) and move them sideways to release the bulb.
- Replace the bulb and proceed in inverse order to block and reconnect it. Observe the bulb closing mechanisms for proper insertion.

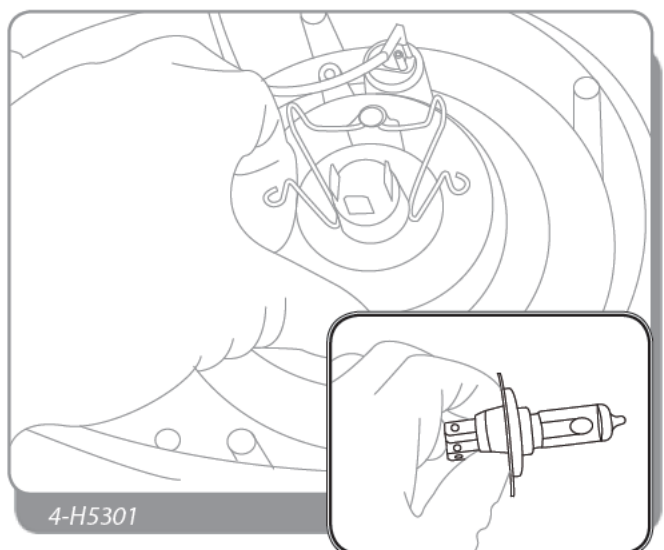

8.5.2 Rear light

In the front headlight (Fig. 5-H5301) it is composed of:

	Description	Type
1	Reverse light	21 W
2	Rear side light	5 W
3	Stop light	21 W
4	Direction indicator	21 W
5	Rear fog lamp	21 W

To access the bulbs:

1. Set the vehicle in the maintenance position.
2. Act on the battery isolator switch to disconnect the supply to the electrical system.
3. Remove the power connector of the rear light.
4. Remove the front part of the light by loosening its screws located on the cap.

Close the light by carrying out these steps in inverse order, being careful to position the sealing gasket correctly.

Replacing the rear light bulb.

- Press the upper part of the bulb.
- Turn the bulb while pressing it down to release it from the lock.
- Carry out the same steps in inverse order to insert the new bulb.

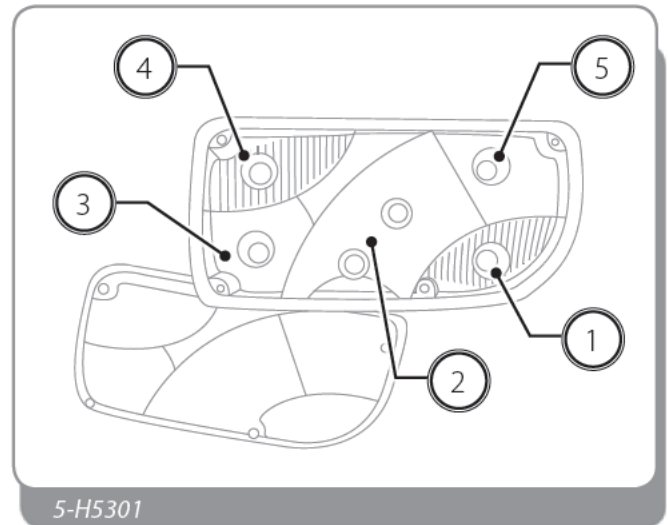

8.5.3 Working light *



*The work light is an optional accessory.

Replacing the working light bulbs

To access the bulbs:

1. Set the vehicle in the maintenance position.
2. Act on the battery isolator switch to disconnect the supply to the electrical system.
3. Remove the power connector of the rear light (Fig. 8-H5301, pos.1).
4. Press the connector socket on the light (Fig. 8-H5301, pos.2).
5. Turn the socket while pressing it down to release it from the lock.
6. Carry out the same steps in inverse order to insert the new bulb.

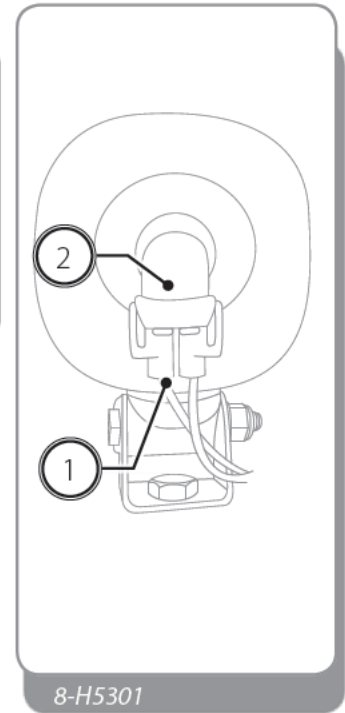
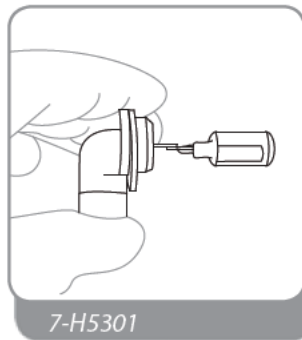

8.5.4 Dual reflector working light *



*The work light is an optional accessory.

Replacing bulbs

To access the bulbs:

1. Set the vehicle in the maintenance position.
2. Act on the battery isolator switch to disconnect the supply to the electrical system.
3. Remove the screws on the front part of the light.
4. Remove the power supply connectors from the bulbs (Fig. 11-H5301, pos.1).
5. Move the locking tabs, bringing them towards the inside to release them (Fig. 11-H5301, pos.2)
6. Carry out the same steps in inverse order to insert the new bulb. Observe the bulb closing mechanisms (Fig. 11-H5301, pos.3) for proper insertion.

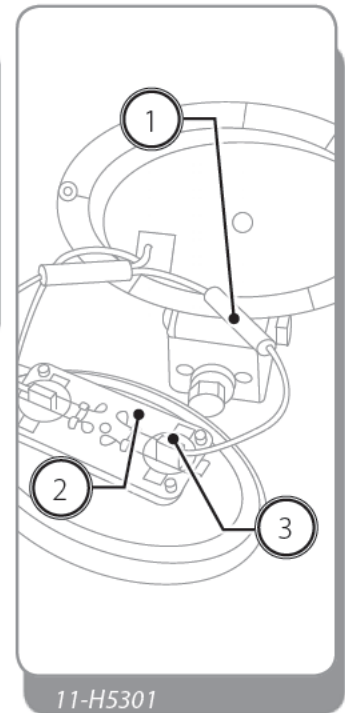
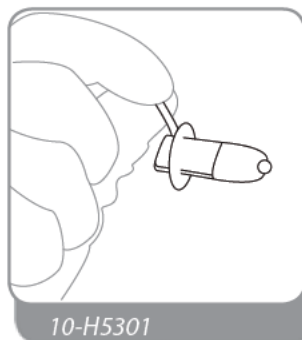
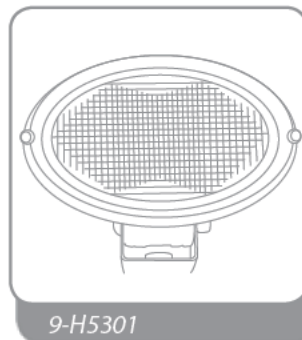

9 SAFE WORK PROCEDURES

9.1 General warnings



For safe working procedures in the various working conditions refer to the "Safety regulations" chapter.



- ATTENTION

Do not use the vehicle without having first read and understood all parts of this manual, and without having attended an adequate training course.



- FORBIDDEN

Do not use the machine if you are under the effect of alcohol, drugs or if you have taken medication that may make you drowsy or alter your reflexes.



- DANGER

Do not use the vehicle when hands or shoes are wet or dirty with grease or greasy substances.



- ATTENTION

Verify that all safety devices function before using the vehicle. The operator must always maintain control of the vehicle state and operation.

Use the acoustic warning device or other signals to alert people in the area before starting up the vehicle.

Inspect control instruments immediately after start up, while the engine is hot and at regular intervals during use, in order to promptly recognise and resolve any malfunctions.



- FORBIDDEN

Do not start the engine or touch the levers of the vehicle if there is a danger sticker stuck inside the cab or maintenance in progress.



- FORBIDDEN

Do not carry passengers on the vehicle or in the driver's cab or on any other part of the vehicle (including passenger conveying basket).



- FORBIDDEN

It is prohibited to use the mobile hydraulic parts of the vehicle the lift people except when using the passenger baskets with relative personal protective equipment for the operator inside.



- NOTE

Regardless of the user's experience, become familiar with the position and function of all controls and instruments in a work area free from obstacles and persons, before operating the vehicle.



- ATTENTION

Carry out all the described safety checks before resuming operations.



- NOTE

While the vehicle is running, always keep light signals on. These serve to warn people that the vehicle is about to move.



- ATTENTION

Always keep the safety distance adequate for the type of work and persons or objects in the work area. Always look in the forward direction and maintain good road visibility.



- DANGER

Adjust movement speed based on the load carried and the type of ground; remain at low speeds to reduce the risk of the vehicle tipping over or losing the load.

Do not drive with the brake pedal pressed.



- DANGER

Do not use the vehicle's force of impact to carry out tasks. These vehicles are not designed for said use; therefore, such use may cause vehicle overturning, damage, the breakage of components and attachments, or serious personal injury for the user.



- DANGER

Always operate with the engine bonnet closed.

Do not operate with removed vehicle protective parts.



- ATTENTION

When working in a congested area, designate one person to signal and coordinate the work zone.

Make sure that everyone follows the directions given by the person in charge of signalling.

Ensure to use signals conform with the dispositions in force in the country of use of the vehicle.



For additional information with regard to the presence of a person in charge of signalling, consult the "Signals to more vehicles" chapter.



- DANGER

When working alongside excavations or on the edge of the road or soft ground, keep at a safe distance as the vehicle may overturn. Designate a person on the ground to be in charge of signalling.

have another person present on the ground.

Remember that after strong rains, the use of explosives or an earthquake, the ground is more fragile.



- DANGER

When working on the upper part or inside buildings or other structures, verify their capacity and stability before starting operations. The risk of collapse exists and can cause serious injuries or damage.



- DANGER

Working on a slope may be dangerous. The conditions of the terrain may vary according to climatic conditions (e.g. rain, snow, ice). Therefore, pay careful attention to the conditions of the terrain on which the vehicle is being used; the use of low speeds is recommended.



- ATTENTION

Drive slowly on grass, leaves or wet steel slabs. Even when operating on slight slopes the vehicle may slip, lose balance or overturn.



- ATTENTION

Tipping conditions of the vehicle can vary depending on the features of the ground, environmental conditions and the type of work.

Complying with all the safety instructions contained in this manual reduces risks for the vehicle and the operator in most operating conditions provided herein.

It is forbidden to use the tractor if there is any risk of tipping that is not covered herein, as this manual contains an incomplete list.

9.2 General warnings for truck mixers



For safe working procedures in the various working conditions refer to the "Safety standards" chapter.



- CAUTION

All the products used for the production of the mix must be handled with the appropriate PPE. Refer to their safety data sheets for additional specific directions.



- PROHIBITION

Do not modify the structure and vehicle stability in any way by trying to add counterweights, whichever artifice is used.

- Reduce the speed as much as possible and brake gently during handling operations.



- WARNING

Avoid passing over unstable objects. Remove dangerous, unstable objects instead of passing over or around them. Also avoid holes or bumps. Before turning, slow down as much as possible.

- Do not change direction abruptly or at high speed.
- Remember that hydraulic steering is very sensitive to steering wheel movements; steer gradually and avoid sudden movements.
- Slow down before turning.
- Be careful to the lateral space. If possible, keep to the center of the passage to avoid equipment or personnel from obstructing your travel.
- Always ensure good visibility in the work area, including direct vision and visibility using rear view mirrors in order to check for the presence of people, animals, obstacles, holes and changes in slope etc.
- Decrease the working speed of the vehicle in case of rain, fog, snow or in any case where visibility is reduced.
- Always make sure there is good visibility (clean windows, clean mirrors, clean lights that work properly, etc.).
- Maintain control of the vehicle and its speed in all circumstances. The speed of the loaded vehicle must never exceed 10 Km/h.
- Do not drive in reverse for long distances.
- Brake gradually; avoid braking abruptly.
- Always maintain the safe distance from other vehicles in order to have sufficient space to brake in every condition.
- Always make sure that, during transport, the drum is always rotating in the "Mixing" mode. This reduces the loss of the load or part of it, and avoids to cause danger of damage to things and persons



- PROHIBITION

Do not raise or lower the drum or the loading shovel when the machine is moving.



- PROHIBITION

Do not use the loading shovel to lift the rear wheels of the machine, during the loading or maintenance operations.



- PROHIBITION

The operator must not climb to check the load or to make washing operations.



- PROHIBITION

The operator must not go inside the drum until it is still mounted on the machine.



- PROHIBITION

It is absolutely forbidden to use hammers, chisels or other tools to remove residual mixture from the drum or from other parts of the machine.



- CAUTION

Road use must occur with the shovel fully up and locked to the appropriate safety chain.



- CAUTION

With the engine running or drum moving, it is obligatory make operations on the ground operations while remaining at a safe distance of safety from moving parts (loading shovel, drum, etc ...).



- DANGER

To check the consistency of the mix, pour a small amount of it on the ground or in a container. Do not try to check the mix from inside the drum.

9.3 Going up or down from the cab

Falls are a major cause of injury to personnel.

When going up or down from the vehicle, always be facing the vehicle and keep contact with the vehicle on three points with the steps and handles.



- PROHIBITION

Do not use the controls as a handle.

Never jump down from the vehicle.

Do not ever go up or down from a moving vehicle.

Never go up or down from the machine with tools in hand.

Always keep the platforms, steps and handles clean to prevent danger of falling.

Before climbing into the cab, make sure your hands and your shoes are clean and dry to avoid slipping and falling.

Use only the handles shown in the photo Fig. 1-I0200.



- DANGER

If the vehicle begins to move without operator inside, do not jump on the vehicle to try to stop it.

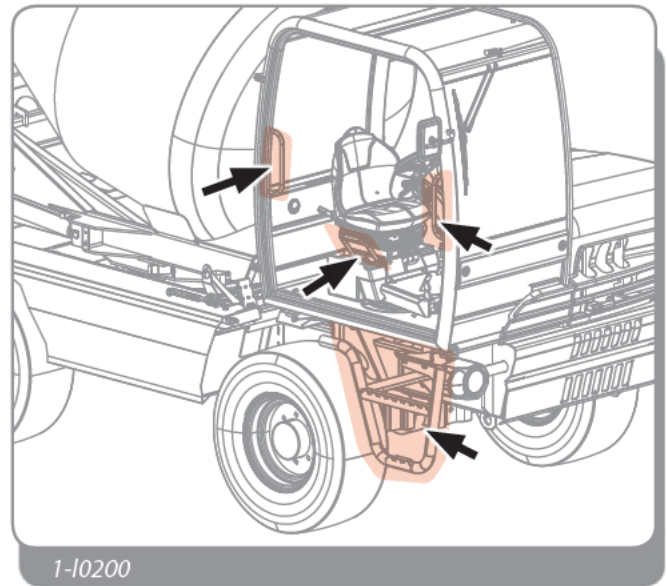

9.4 Operator's seat adjustment



- WARNING

Use the machine only with the seat correctly adjusted. An inadequate adjustment can quickly fatigue the operator letting him make incorrect operations, alter the perception of the position of the controls and external objects, affect the sensitivity in the operations.

The seat must be adjusted according to the height and weight of the operator.

The operator must be able to fully press the pedals and to operate correctly the control levers with his back against the backrest of the seat. If not, make the necessary adjustments of the seat, and check again.

The seat allows different adjustments (Fig. 10-10200):

1 - Seat longitudinal adjustment

For the longitudinal adjustment of the control unit move lever "1" sliding the seat on the guides. Once established the desired position, release the lever. Make small movements to ensure that the stop pin is engaged in its seat.

2 - Suspension degree adjustment

For the suspension degree adjustment rotate the lever "2". Turning the handle clockwise will decrease the suspension, while turning the lever counter-clockwise will increase the suspension.

3 - Seat height adjustable (seat only)

To adjust the seat height, turn the knob to "3". Turning clockwise will lower the seat while rotating counterclockwise will raise the seat.

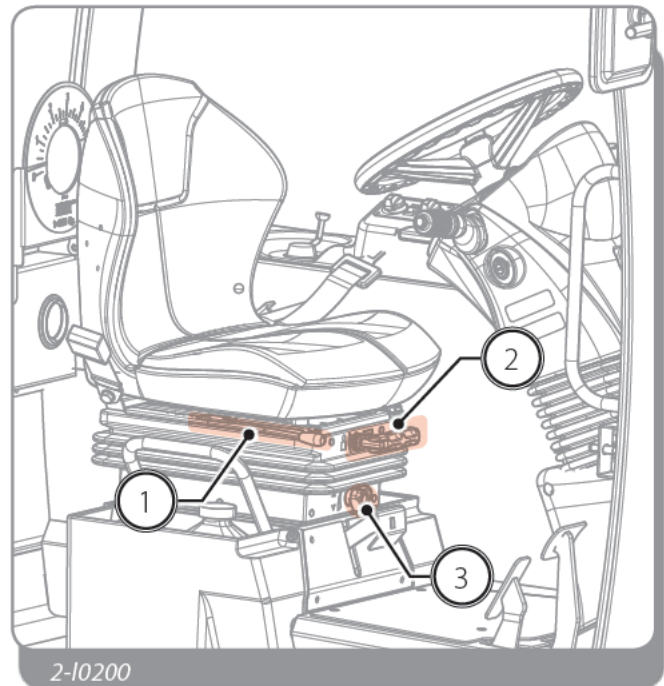

- CAUTION

The seat is properly positioned when the operator is able to perform a full stroke to the brake pedal by holding the back against the backrest of the seat itself.

9.5 Fastening the seat belt

The machine is equipped with a cab that can withstand the weight of the machine in the event of rollover (ROPS), it is therefore necessary that the operator remains tied to the seat by the seat belt not to be swept out and possibly crushed.

Before starting the machine, carefully examine the straps, buckles and fastening devices to the structure. If some component is damaged or worn, replace the seat belt or the component before operating the machine.

Remain seated with the seat belts fastened properly for all the time of operation of the machine to reduce the risk of injury in case of accident.

Following an accident of a certain importance, replace the seat belts, even if they do not appear damaged.

To fasten the seat belt is necessary to:

1. Insert the latch plate "1" in the buckle "2" (Fig. 3-I0200).
2. Make sure of that the hooking occurred, and then adjust the belt around the body (Fig. 4-I0200).



- CAUTION

The belt is considered properly connected when it is close to the body.

To remove the belt it is necessary to (Fig. 5-I0200):

1. Press the red button "1" on the buckle "2".
2. Then remove the latch plate "3".



- CAUTION

Drive the vehicle only with safety belt properly worn, fastened and adjusted. Operating without the seat belt fastened increases the risk of accidents.



- PROHIBITION

Do not use damaged or worn seat belts. If worn, damaged or yielded belts are used, they can break or yield in case of collision resulting in serious injury to the operator.

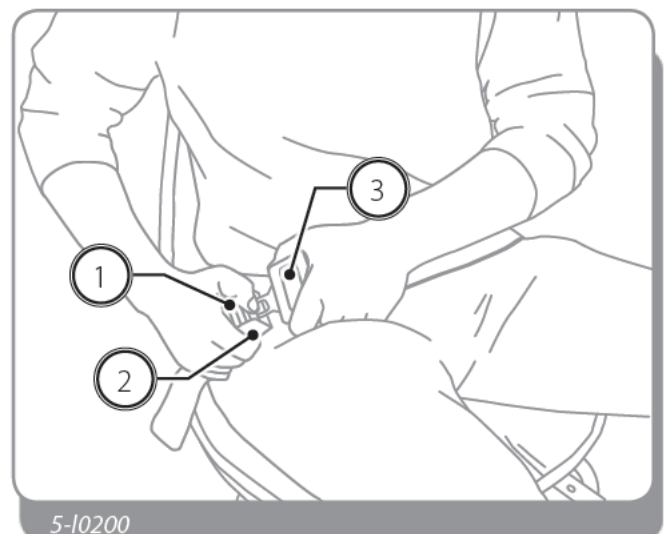
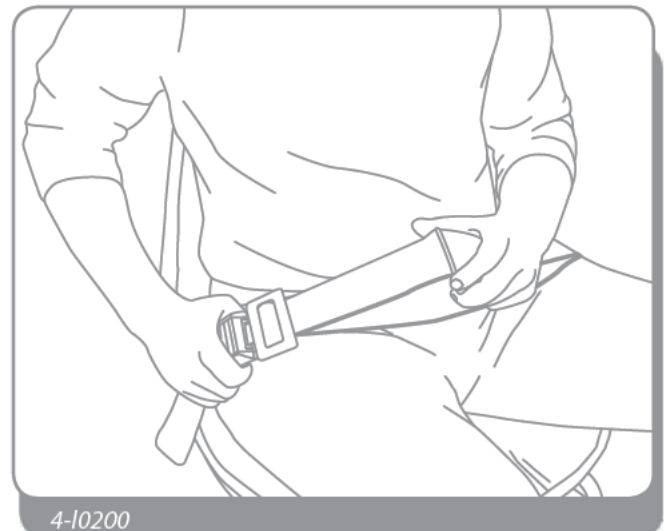
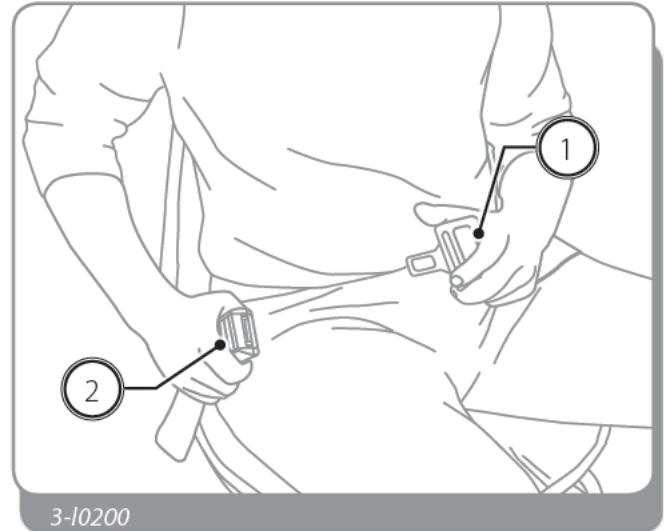

9.6 Inspections prior to starting-up

9.6.1 *Inspecting the machine*

Carefully inspect your machine every day or before every shift.

Carry out the following inspections and operating checks:

- Parking brake efficiency
- Intact condition of the tires
- Type of tire suitable for the type of work ground
- Engine oil level (check and top-up, if necessary)
- Hydraulic oil level (check and top-up, if necessary)
- Air filter clogging indicator (check and clean, if necessary)
- Tire inflation and pressure (check)
- Fuel level (check)
- Signaling and warning devices (check)
- Steering efficiency
- Service brake efficiency
- Tightness of all nuts and bolts
- Lighting
- Direction indicators
- Emergency Lights
- Switches
- Indicator lights
- Windscreen wipers
- Reverse movement alarm
- Position and condition of rear view mirrors



- DANGER

Immediately stop using the machine in case of malfunctions or if it does not comply with safety standards.



Contact an authorized *DIECI S.R.L.* workshop if the machine shows malfunctions. Refer to the "Maintenance" chapter for information regarding routine maintenance.



A thorough inspection is required if the machine is not used for a prolonged period of time. A detailed description of the operations is provided in the "Machine storage" chapter.

9.6.2 *Inspecting the work area*

- Examine the work area when working at the edge of an excavation or on soft ground as the machine could overturn.
- Examine the conformation and condition of the terrain of the work area before beginning to operate.
- Keep the machine well away from the edge of the excavation and the side of the road.
- When working on a slope or near the roadside, have another person present for signaling.
- Pay utmost attention when working on icy ground. The ice will melt as the temperature rises and the ground will become slippery.
- Check for any overhead power lines or underground piping.
- Do not work in places at risk of landslides or falling rocks.
- Take due precautions to prevent any unauthorized persons from entering the working area.
- When moving through or operating in shallow water or soft ground, verify the shape and the conditions of the land, the water depth and flow rate before beginning the operation.

9.7 Starting and stopping the machine

9.7.1 General warnings regarding starting up the machine



- CAUTION

Do not use the machine without having first read and understood all parts of this manual, and without having attended an adequate training course.



- DANGER

Before starting the engine, make sure all control levers are in a neutral position, the parking brake is engaged, the engine hood is closed and that there is nobody in the area surrounding the machine.



- DANGER

The machine can only be started up or maneuvered when the operator is seated in the driver's seat, with the seat belt fastened and adjusted.



- DANGER

The machine may move suddenly if started up without following the correct procedure, thus, creating the risk of damage.



- PROHIBITION

Never start the engine by causing a short circuit between the terminals of the starter.



- PROHIBITION

Never start-up the engine by pushing or pulling the machine. This could seriously harm people or cause serious damage to the machine.



- DANGER

Be careful when using auxiliary batteries as the gas contained in these may explode, causing serious damage.



Follow the instructions provided in the "Emergency procedures" chapter, "Start-up using auxiliary batteries" paragraph to start the engine using auxiliary batteries. An incorrect procedure can cause serious damage to the electrical/electronic system, the machine could move suddenly, the battery could explode and damage could be caused to objects and/or people.



- PROHIBITION

Do not start the engine or touch the machine levers if a danger sticker or a maintenance in progress sign is placed inside the cab.

9.7.2 Starting-up the engine

Proceed as follows to start-up the engine of the machine:

1. Press the parking brake switch.
2. Set the gear selection lever in the neutral position.
3. Remain seated in the driver's seat.
4. Turn the ignition key (Fig. 2-10200) clockwise to position "1".

With the key in this position:

- The control panel and instrument panel will be powered
- A buzzer will sound, indicating that the key has been inserted. This buzzer also serves to warn any persons in the surrounding area that the machine has been started up.
- A check-up of the instrumentation will be performed with all the indicators lighting up for about 5 seconds. Only the following lights must remain switched on at the end of the check-up:
 - Engine oil pressure indicator light
 - Battery charge indicator light
 - General alarm warning light
 - Intermittent buzzer
 - Other indicators of activated functions (e.g.: Parking brake, gears engaged, etc.)



- PROHIBITION

If other indicators remain on signaling malfunctions or if one of the previous conditions does not occur, do NOT start-up the engine and refer to the "Maintenance" chapter or contact the Dieci service center.

5. Turn the ignition key (Fig. 2-10200) to position "3" to start-up the engine. Release the starter within 5 seconds.
6. Release the key once the engine has started. The indicators related to the engine oil pressure and battery charge must go off once the engine is started up.

If the engine does not start within 5 seconds, try again at regular 15 second intervals to prevent overloading the starter.



If the engine does not start at all, refer to the "Maintenance" chapter of this manual or contact the DIECI service center.



- WARNING

With the engine started, the automatic parking brake disengages. Always verify that the parking brake has been engaged through the button before starting up.

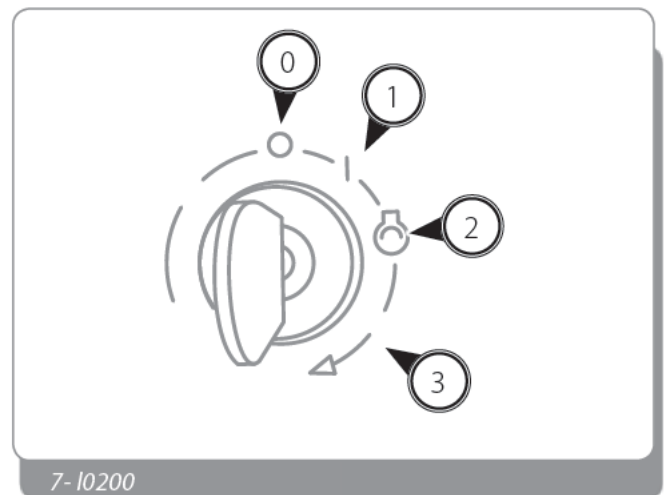
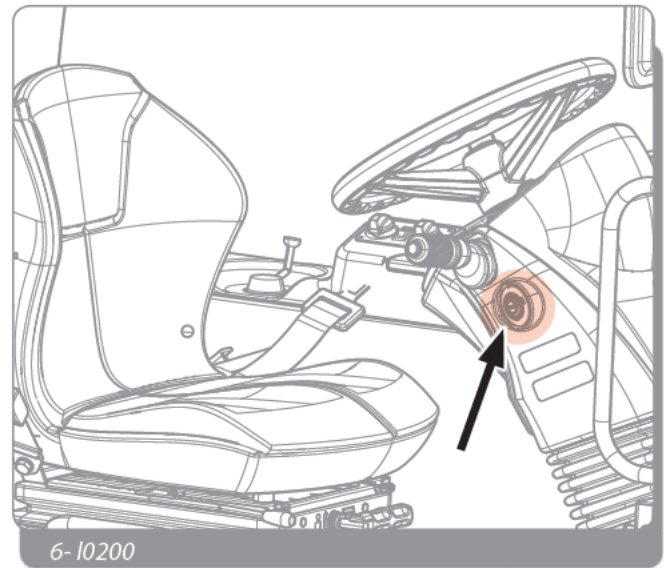

9.7.3 Warm-up after starting-up

During the first few minutes of use, keep the speed slow in order to warm up the engine and hydraulic oil.



- DANGER

Serious damage can be caused to the engine and the hydraulic system if the engine reaches high rpm before the operating oil temperature and pressure levels are reached.



- WARNING

Let the engine run at 1100 - 1300 rpm for about 5 minutes so as to bring the engine oil to the operating temperature, particularly, with outdoor temperatures around 0 °C.

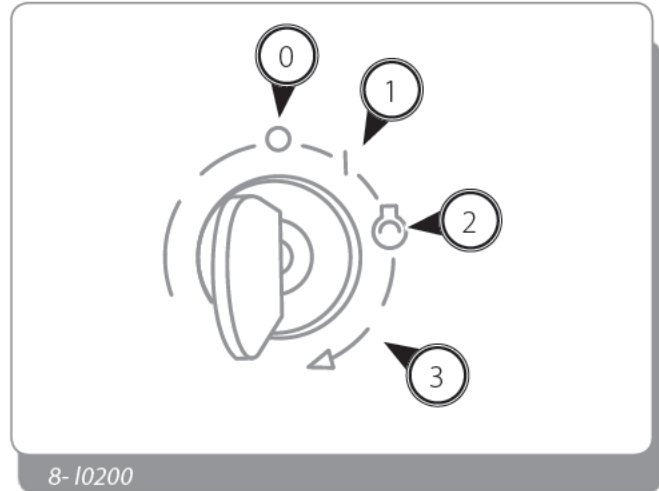

9.7.4 *Start-up at low environmental temperatures*

Consider the following warnings before starting-up at low environmental temperatures and with a cold engine:

- In order to prevent discharging the battery, do not prolong each attempt to start-up by more than 15 seconds; however, if the engine does not seem to be starting-up, extend the time to a maximum of 30 seconds.
- Wait at least one minute before trying to start-up again.
- It is recommended to not exceed six start-up attempts so as not to discharge the battery excessively.



- WARNING

It is recommended to use anti-freeze diesel at environmental temperatures lower than 0°C, so as to make sure the engine is optimally supplied, without reducing performance, also at environmental temperatures lower than -20°C.

9.7.5 *Causes of failed start-ups*

Check the following if the engine does not start-up:

- The parking brake switch is pressed
- The gear selection lever is in the neutral position
- The emergency stop buttons placed at the sides of the machine are not pressed

After checking all the previous conditions, remove the cause of failure to start and try the starting procedure again.



If the problem persists, contact a DIECI after-sales center

9.7.6 *Turn off the machine*

It is recommended to perform the following before switching the engine off:

1. Bring all the control levers to the idle position
2. Bring the engine to low speed for at least 3 minutes
3. Turn the ignition key to position "0" (Fig. 8- I0200).

9.8 Moving safely



- CAUTION

In the event of scarce visibility, use the help of a person on the ground for signaling.

9.8.1 Moving on sloped ground

Operating on sloped terrain can cause overturning or sliding. Move forward and brake gradually and take all necessary cautions.

Always move in a straight line to go up or down a slope. Moving transversally or along the slope is extremely dangerous (Fig. 9-10200).



- DANGER

When on a sloped surface, pay attention to the conditions of the ground. When working with the machine on an sloped surface, pay particular attention during the machine loading and unloading.



- PROHIBITION

Do not stop and leave the vehicle parked on a slope exceeding 15%, even with the parking brake engaged.

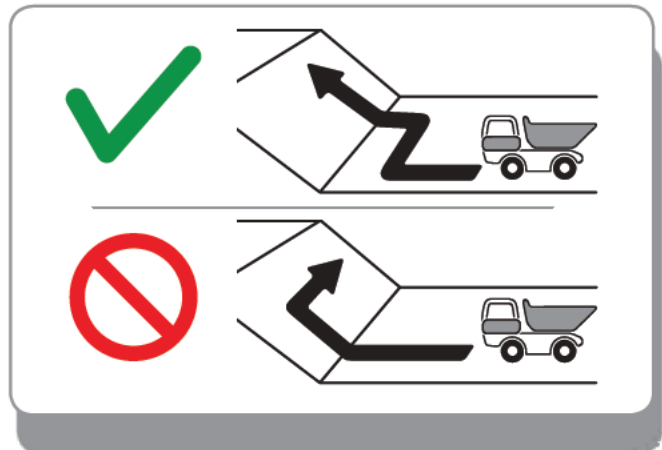

9.8.2 Driving uphill with a full load

When having to drive uphill while transporting a load, operate with the machine facing downhill (Fig. 10-10200).



10-10200



11-10200

9.8.3 Driving uphill without a load

When having to drive uphill without a load, operate with the always vehicle facing uphill (Fig. 11-10200).

9.8.4 Driving downhill with a full load

When having to drive downhill while transporting a load, operate with the machine facing downhill (Fig. 12-10200).



12-10200



13-10200

9.8.5 Driving downhill without a load

When having to drive downhill but without a load, operate with the vehicle facing downhill (Fig. 13-10200).

9.9 Road travel

9.9.1 Road travel warnings



- CAUTION

Before starting the road travel make sure to observe the relevant laws and regulations in the country of use.

The road travel requirements are shown on the Vehicle Registration Document.

Low beam lights must be on even during the day and in streets where there is no obligation to use visual and lighting signaling devices.



- WARNING

Check the correct position of the rear view mirrors. The objects seen through the rear view mirror are closer than they appear.

When driving on the road and/or on a slope it is necessary to be very careful to the engine rpm. A high number of rpm can lead to mechanical failures. Keep under control the motor rpm and speed.

Pay particular attention to loading docks, trenches, scaffolding and land recently excavated or filled

9.9.2 Road travel instructions

- Check the correct operation of the lights before moving on roads. Check that the rotating light for slow vehicle signaling is installed and running; keep the rotating light in operation both at day and at night.
- Perform the wheels alignment, so that they are perfectly aligned with the vehicle chassis.
- **It is mandatory** to arrange the steering as reported in the Vehicle Registration Document and lock the selector lever with the dedicated device. In Italy select the steering on four wheels; on public roads do not use the transverse or two wheels steering mode.
- Make sure that the amount of fuel is sufficient.
- Assemble all the accessories required for road circulation depending on the country in which the machine is operating.
- Always evaluate the road to be traveled, taking account of suspended structures (e.g. bridges, underpasses, etc.) that could be damaged by the machine.
- Make sure that your machine is in compliance with local legislation in reference to the presence of the license plate when traveling on the road both at day and at night.
- Fasten the seat belt.



- PROHIBITION

It is not allowed to travel on public roads with the loaded machine.

9.10 Momentary stop

- Gradually release the accelerator pedal.
- Stop the machine on even ground.
- Engage the parking brake
- Move the "gear change lever" to "N".
- In the running in period (50h) do not keep the diesel engine idle for a too long period.



- CAUTION

If it is necessary to leave the driving position, follow the steps in the "Parking the vehicle" paragraph.



- PROHIBITION

Never move away from the vehicle, leaving the engine running or the ignition key on the machine.

9.11 Parking the vehicle



- PROHIBITION

Never leave in any case the vehicle parked with a raised load.

- Always park on flat, firm and level ground, where there is no risk of falling rocks, landslides or flooding.
- Engage the parking brake
- Move the "direction of travel" lever to "N"
- Run the engine at idle speed for about 3 minutes before turning it off, in order to allow the engine cooling
- Turn the ignition key to the engine stop position
- Remove the key from the ignition switch
- Lock the hydraulic controls with the special devices (where present)
- Close the windows and lock them with the handles (if present)
- Close the cab door by key (if present)
- Place wedges under the wheels
- Make sure that the machine is parked so as not to impede its movement and at least 5 meters away from the railroad tracks.



- PROHIBITION

Do not stop and leave the vehicle parked on a slope exceeding 15%, even with the parking brake engaged.

9.12 Driver's seat reversal

To facilitate the machine loading and unloading operations, it is possible to rotate the operator's driving seat to better carry out the operations and achieve a correct visual.

To correctly reverse the driver's seat, it is necessary to:

1. Stop the machine (possibly on a level ground).
2. Press the parking brake switch.
3. Place the gear lever to neutral ("N" position).
4. Fully open the door (if available as an option).



- CAUTION

Make sure there are no obstacles to the rotation of the seat on the bottom of the cab (rags, gloves, dirt, etc ...), the seat may become jammed or the sensors may not work properly.

5. Press the driver's seat pedal inversion pedal, placed under the operator's seat.
6. Keeping the pedal pressed, manually rotate the driving seat with the help of the handles in the cabin.
7. Turn the driver's seat to the stroke end and release the pedal.



- CAUTION

After turning the driver's seat, the power steering indicator light will turn on and an intermittent buzzer will operate.

8. Make sure the driver's seat is properly secured.
9. Lower the power steering reversal lever to make the steering movements consistent with the wheels movement. The light and intermittent acoustic signal will be switched off.



- PROHIBITION

It is strictly forbidden to work with the driving seat partially rotated.



- WARNING

With driver's seat reversed, also the gear shift lever function will reverse to select the direction of travel (forward/reverse) in order to remain consistent with the operator's position.



- DANGER

Avoid long travels operating with reversed driver's seat.

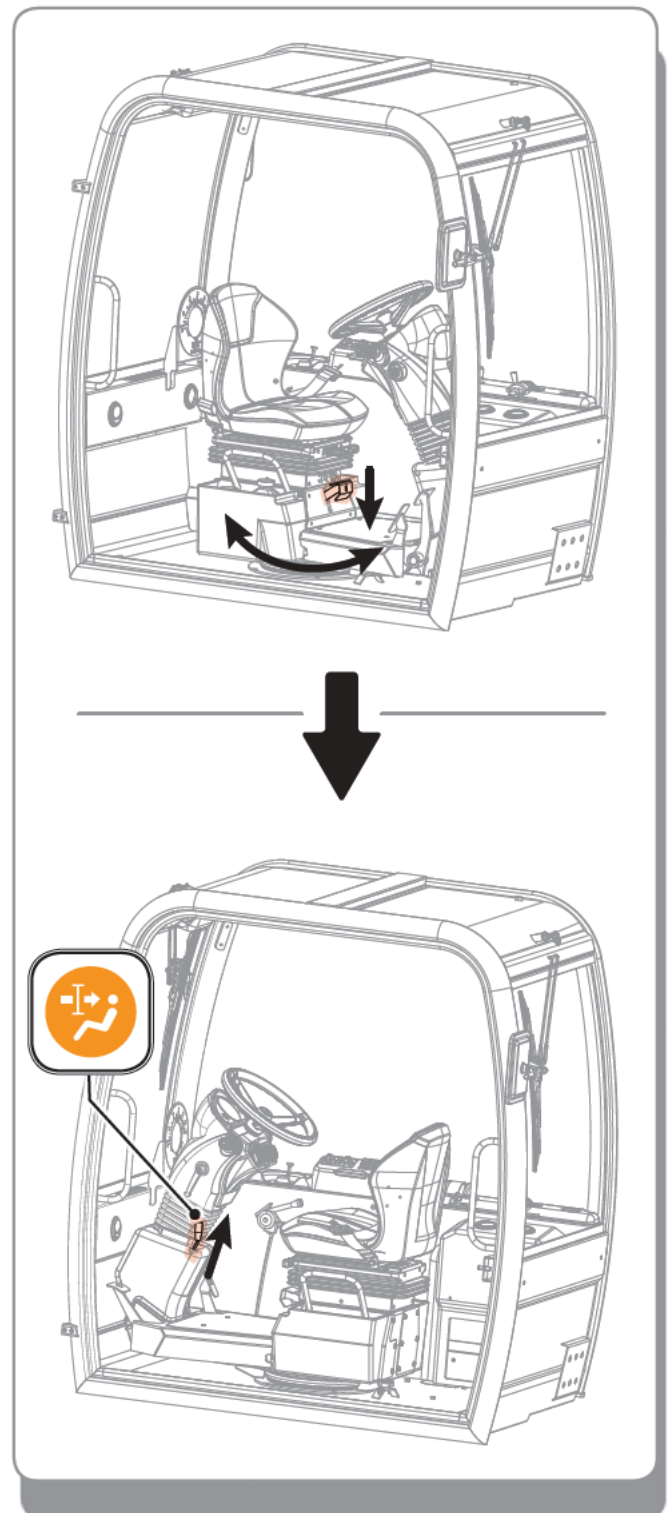



- WARNING

With the driver's seat turned towards the drum, the visibility of the field of action is very low, so for the operations it is required to use a person on the ground to give indications.



- PROHIBITION

It is not allowed to travel for long distances with the driver's seat reversed. If this should be necessary (e.g. driving uphill) the presence of a person on the ground to give indications, is required.



- PROHIBITION

It is not allowed to drive the vehicle on the road with the driver's seat reversed.

9.12.1 *Driver's seat restoring*

To restore the driver's seat in the transport position, carry out the following operations:

To correctly reverse the driver's seat, it is necessary to:

1. Stop the machine (possibly on a level ground).
2. Press the parking brake switch.
3. Place the gear lever to neutral ("N" position).
4. Fully open the door (if available as an option).



- CAUTION

Make sure there are no obstacles to the rotation of the seat on the bottom of the cab (rags, gloves, dirt, etc ...), the seat may become jammed or the sensors may not work properly.

5. Press the driver's seat pedal inversion pedal, placed under the operator's seat.
6. Keeping the pedal pressed, manually rotate the driving seat with the help of the handles in the cabin.
7. Turn the driver's seat to the stroke end and release the pedal.
8. Make sure the driver's seat is properly secured.
9. Lift the power steering reversal lever to make the steering movements consistent with the wheels movement. The light and intermittent acoustic signal will be switched off.



- PROHIBITION

It is strictly forbidden to work with the driving seat partially rotated.

10 EMERGENCY PROCEDURES

10.1 Warnings if the vehicle should overturn

- The safety belt is the best protection if the vehicle should overturn to its front or side;
- Keep calm: remain on board and do not try to jump out of the driver's seat;
- Hold the steering wheel with both hands;
- Press your feet against the floor, keeping them inside the driver's seat;
- Tilt your body in the opposite direction to that of the fall;
- To avoid banging your head, near your head as much as possible to the steering wheel.

10.2 Start-up using auxiliary batteries



- ATTENTION

Starting up the engine with auxiliary batteries requires two adequately trained and qualified persons.

Failure to follow correct procedure can cause serious damage to the vehicle, things or people.

- When starting the engine using another vehicle, connect up the accumulators in parallel. When connecting the cables, avoid contact between the positive cable (+) and negative cable ("").
- Wear adequate personal protective equipment before carrying out any operation.
- Take care to avoid contact between the vehicle to be started up and the vehicle that must supply the power, in order to avoid sparks and consequently explosions caused by the hydrogen produced by the accumulators. Explosion of the accumulator may cause serious damage and injury.
- Make sure not to mix up the start-up cables; connect the ground cable first (-) and the positive cable last (+).
- Use extreme care when removing the starting cables; make sure that when the cables are disconnected from the accumulator, they do not touch other parts of the vehicle in order to avoid hydrogen explosions.



- ATTENTION

The cables and clamps must be proportional with the current load to be transferred. The accumulator used for start-up must have a greater or at least equal capacity to that of the standard accumulator.



- ATTENTION

Check that the cables and clamps are not corroded or damaged. Make sure the clamps firmly grip the terminals.



- ATTENTION

Pay great attention during the various operations. Direct or indirect contact with live parts can cause injuries and in some cases even death.



- ATTENTION

When the engine is being started up, the operator must be seated in the driver's seat in order to monitor the vehicle.



- NOTE

These operations must be carried out by competent, trained personnel.

10.2.1 *Connecting the cables and starting the engine*

1. Make sure that the ignition key is at position "O".
2. Connect the positive poles "+" of the two batteries.
3. Connect the negative terminal cable "-" of the charged battery to the block of mass of the vehicle that is to be started up.
4. If a charged battery already installed on a vehicle that operates correctly is used, start-up the engine of the latter and bring the engine to a high rpm.
5. Start up the engine of the faulty vehicle.

10.2.2 *Removing the cables*

With the engine running, remove the cables in the opposite order in which they were connected.

1. Disconnect the negative cable "-" from the block of mass of the started engine and then from the charged battery.
2. First disconnect the positive cable "+" from the battery used for start-up and then from the flat battery.

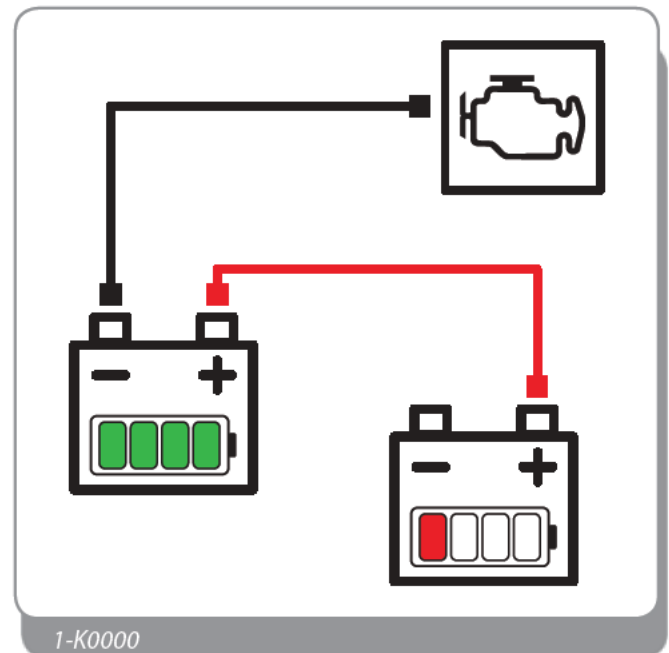



10.3 Machine towing



- CAUTION

The machine towing is a delicate operation and the risks to the operator are high. The manufacturer's warranty is not applicable in case of incidents or accidents that occur during towing. If possible make repairs where the machine is located.



- WARNING

It is advisable that the towing operations are carried out by skilled personnel.



- PROHIBITION

It is absolutely forbidden:

- Ever try to start the machine by pushing or towing.
- To tow the machine on public roads and for very long paths, if possible keep the yellow flashing light and the emergency lights in operation.
- To tow the machine on a slope.
- Stand between the towing machine and towed machine.



- CAUTION

With the engine off the steering wheel and brakes servo controls do not work. If it is not possible to keep the engine running while towing the machine take into account that the efforts to use the steering wheel will be much higher than normal.



- CAUTION

The machine towing can be made only in emergency conditions at a maximum speed of 4 km/h (2.5 mph) and for short distances up to 500 m (1640 ft).

To tow the machine over longer distances, contact *DIECI* service center.



- CAUTION

It is mandatory to tow the machine with a rigid towing bracket. The towing bracket must be designed for a tensile stress of 10 tonnes (22040 lb). Attach the towing bracket between towing vehicle and the vehicle in failure at the points prearranged for towing.

10.3.1 Machine towing with engine running

If it is necessary to tow the machine with the engine running (for example, transmission failure) follow the following steps:

- Attach the towing bracket between the towing vehicle and the vehicle in failure at the points prearranged for towing (Fig. 1-K0100)
- Move the gear selector lever in position "N"
- Deactivate the traction "1" e "2" (Fig. 2-K0100).
- Disconnect the parking brake switch
- Remain seated in the driver's seat while towing to avoid that the automatic parking brake engages automatically



Follow the steps described in the chapter "Manually disable the towing".

10.3.2 Towing the machine with engine in failure

In case it is necessary to tow the machine with engine in failure, follow the following steps:

- Attach the towing bracket between towing vehicle and the vehicle in failure at the points prearranged for towing (Fig. 1-K0100).
- Deactivate the traction "1" e "2" (Fig. 2-K0100).
- Manually disable the parking brake on the rear axle of the machine to "3" (Fig. 2-K0100).



- DANGER

With the engine off, the drive and parking brake are still active. Towing the machine with active drive and brake can cause serious damage to the machine and create dangerous situations when towing.



Follow the steps in the section "Manually disable the external parking brake" and "Manually disable the drive".

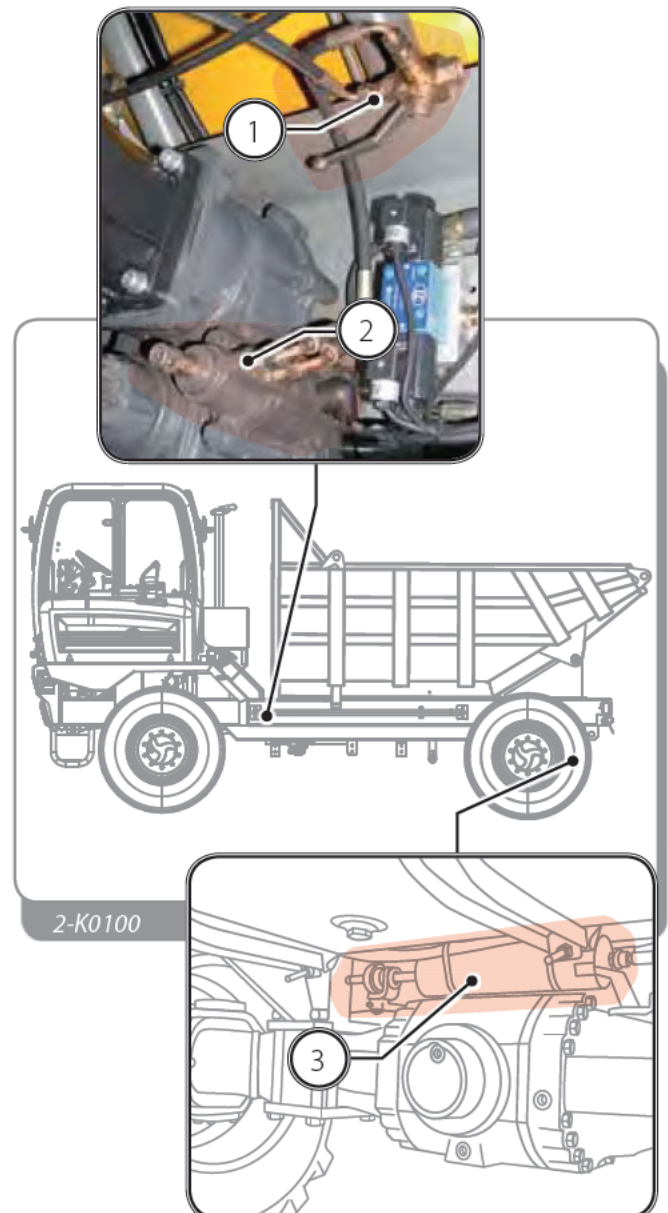

10.4 Deactivating the external parking brake manually

The parking brake must be disconnected directly on the axle for the vehicle to be trained.

1. Place safety wedges under the wheels to prevent the vehicle from moving suddenly
2. Position a screwdriver in the head of the crown (Fig. 1-K0102)
3. Use a rubber mallet to strike the handle of the screwdriver in order to push the crown inwards so as to block the retainer.
4. When the crown is released at the end run, towards the outer part of the vehicle (Fig. 2-K0102), the parking brake is disengaged and the vehicle can be towed.



- NOTE

Even if the parking brake is disengaged, it will re-engage automatically upon engine start-up.



- FORBIDDEN

Never use the vehicle with the negative parking brake disengaged/disconnected.

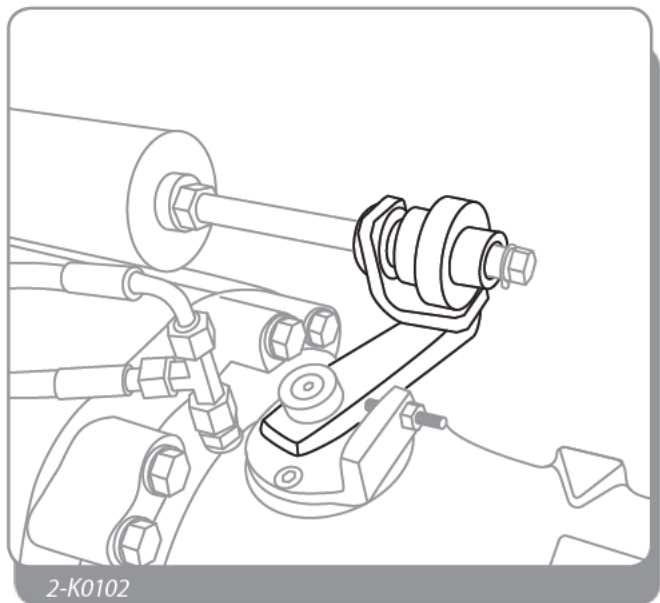
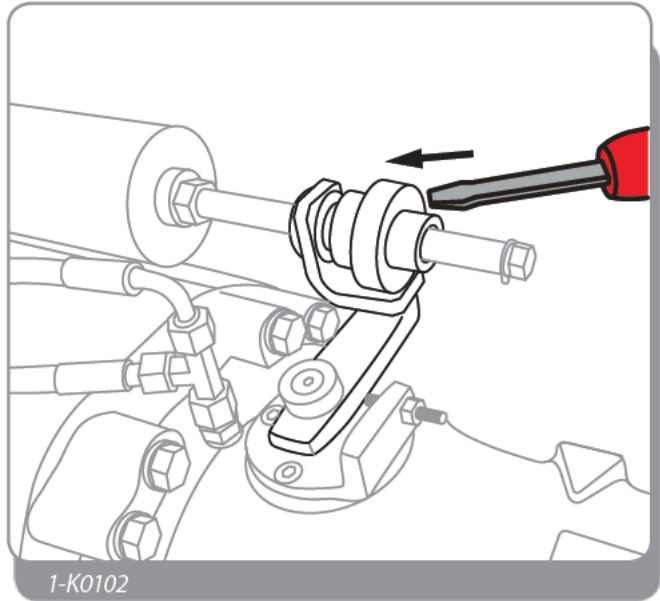

10.5 Deactivate transmission manually



- DANGER

Only deactivate the drive if the vehicle must be towed with a faulty engine and/or transmission.

Transmission can be deactivated manually if the vehicle must be towed with a faulty engine and/or transmission.

Perform the following operations:

- Make sure the engine of the vehicle is off
- Place wedges under the wheels to prevent the vehicle from moving suddenly
- Turn the hydraulic tap lever (Fig. 1-K0111), to close the hydraulic supply to the reduction gear (the tap is under the vehicle, next to the reduction gear).



- DANGER

A jet of pressurised oil can leak from the tap when the handle is turned. Use adequate safety devices to protect the eyes and skin from hot pressurised oil.

- Use a screwdriver to move the gear selection pin to the neutral position, up to half the end run (Fig. 2-K0111, pos. 2)
- Before towing the vehicle, switch the dashboard on and if possible, make sure the forward and reverse gear indicators are off.



- ATTENTION

Once the towing operations are complete, reopen the tap, bringing the lever back (Fig. 1-K0111) to its original position.

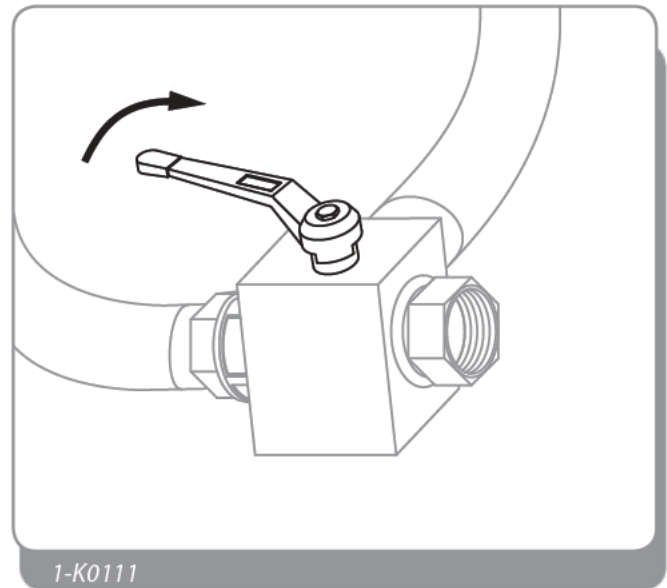

1-K0111

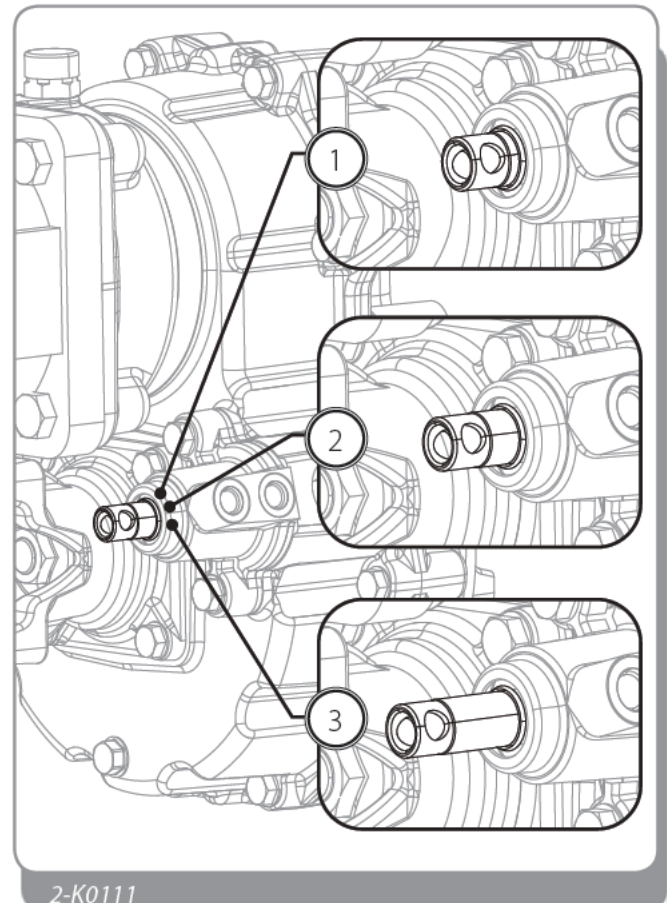

2-K0111



11 MAINTENANCE

11.1 Maintenance warnings

This vehicle has been designed and built to provide maximum performance, savings and facilitate its operation in various working conditions. Before delivery, the vehicle was tested both by the Manufacturer and by the Dealer to ensure its maximum condition. To preserve these conditions and guarantee problem-free operation, it is important to carry out the routine maintenance operations described in this manual at an authorised **DIECI** dealer in accordance with the maintenance schedule provided.

This section of the Manual provides all the maintenance prescriptions necessary for maintaining the **DIECI** vehicle in perfect working condition.

The vehicle must receive regular routine maintenance in order to give the best results. It is recommended that all services be carried out as prescribed in the service schedule suggested by **DIECI**. Remember that it is the owner's and/or users responsibility to keep the vehicle in safe working condition and suitable to be driven on public and private roads.

Proper vehicle maintenance not only improves the vehicle reliability but it also preserves vehicle value over time.



- ATTENTION

Maintenance or adjustment operations not described in this chapter or in the rest of the manual must be carried out by qualified personnel respecting the conditions of safety in order to guarantee their safety and the safety of others. Only **DIECI** Dealer maintenance staff have been trained to carry out said interventions and only they have the special equipment and tools necessary to guarantee maximum safety, precision and efficiency.



It is mandatory to have read and learned the "Safety Standards" chapters before reading the "Maintenance".



- FORBIDDEN

It is prohibited to service the vehicle if this manual has not been read and this chapter learned.



To know the maintenance operations and timetables, see the Maintenance Register.



- ATTENTION

All maintenance operations must be recorded in the specific Maintenance Register.



- ATTENTION

In case of operating in corrosive environments, intervene with adequate modes and times of maintenance to avoid excessive wear of the equipment.



- ATTENTION

Use adequate personal protective equipment during the various inspection and maintenance operations.



- FORBIDDEN ACTION

In the event of malfunction, do not use the vehicle until it has been repaired.



- ATTENTION

Any modification made to the vehicle entails a new conformity check. This procedure is also valid in the case of repairs with non-original spare parts.



Only the following checks can be carried out by the operator: liquids level, air filter cleaning, tyre pressure. These operations must be performed in compliance with safety standards as described in this manual.

11.1.1 Avoid accidents during maintenance

- Always keep the work site clean and organised in order to guarantee safe operation of the vehicle. .
- Do not leave tools or other instruments laying around in a disorderly fashion at the work site.
- Clean traces of grease, oil and other substances that could cause slipping.
- Always deposit cloths soaked with grease and/or inflammable materials in a safe container to ensure safety at the work site.
- Only use attachments that are appropriate for the job and ensure their proper use. The use of damaged, defective, makeshift, unsuitable and poor quality equipment may cause serious injuries.
- Do not hit the vehicle or its parts with a hammer or any other instrument, as projected fragments could cause injury.
- If inspection or maintenance is carried out on vehicles which are still covered with mud, oil, etc., operators risk sliding or falling and the visual analysis of components is made more difficult. Carefully clean the vehicle before repair or maintenance work is carried out.
- Ensure you are familiar with maintenance procedures before starting work.
- Keep the work zone clean and dry.
- Do not lubricate parts or carry out maintenance work with the engine running.
- Replace any worn or broken parts.
- Eliminate any grease and oil deposits.
- The knurled plates (bulb plates) and the cab floor are the only parts of the vehicle that can be stepped on. Use a ladder (suitable for the intended purpose) for maintenance of parts that cannot be reached from the ground.



- DANGER

Do not carry out maintenance on a moving vehicle. Should maintenance need to be performed with the engine running, ask at least two workers for help and observe the following instructions:

- One worker must always be seated in the driver's seat, ready to switch off the engine at any time.
- All workers must remain in contact with one another.
- Take care not to remain entrapped in components during the execution of operations performed on the fan, fan belt or other rotating parts.
- Do not touch levers or control pedals. Should a lever or pedal need to be moved, always warn operators first so they can move out of harm's way.
- Do allow instruments or other objects to fall into the vehicle's rotating parts, as these parts may break and be projected out.
- The vehicle must be outdoors when the engine is running. The vehicle can be kept in a closed area only if it is properly ventilated and the vehicle is equipped with specific purifiers.



- ATTENTION

If you need to work under raised mobile parts (booms, shovels, etc.) block them using spacers placed on cylinder rods or lean them up against appropriately sized supports.

If you need to perform repair or maintenance work under the vehicle, firmly support the equipment being used and the vehicle with blocks that are solid enough to support the weight.

- Store attachments removed from the vehicle in a safe place where they do not risk falling. Take precautions to prevent unauthorized persons from approaching the storage area.



- ELECTRICAL SYSTEM DANGER

Do not rest metal parts on the battery.

- Welding operations must always be carried out by qualified welders and in areas equipped with suitable equipment. There is danger of gas leaks, fire or electrocution during welding operations; Do not allow unqualified personnel to carry out such operations.
- Disconnect the battery wires before working on the electrical system or before carrying out arc welding on the vehicle.
- When carrying out electric welding, connect the earth of the welding machine as close as possible to the area to be welded, and prevent the electric current from passing through ball bearings, articulated joints, hydraulic cylinders or sliding parts. If welding must be done in proximity to the oil or fuel tank, empty the tanks before welding.



- ENTANGLEMENT DANGER

Damage may be caused by entanglement in moving parts. Prevent accidents while you are working by ensuring that hands, feet, clothing, jewellery and hair cannot get caught in moving parts.



- EXHAUST GAS DANGER

Exhaust gases are toxic and can damage your health.



- DANGER

The vehicle must be outdoors when the engine is running.

The vehicle can be kept in a closed area only if it is properly ventilated and the vehicle is equipped with specific purifiers.



- PRESSURISED LIQUIDS DANGER

After operation, the engine cooling liquid is hot and under pressure. Contact with hot water or steam may cause serious burns.

- Do not attempt to loosen connections, tubes or hydraulic components when circuits are under pressure.
- Avoid possible injury caused by hot water jets.
- Do not remove the radiator cap until the engine has cooled down.
- Before removing the cap, release all of the pressure.
- Prevent burns caused by oil or other hot parts during inspection or discharge by allowing the oil and cap to cool down before beginning operation.
- Even after the oil has cooled down, slightly loosen the cover or cap before removing it to mitigate pressure inside.



- BURNS DANGER

Attention to burns. Engine reduction gear oil and the hydraulic system, pipes, engine and other components heat up when the vehicle is used. Wait until all parts cool down before beginning maintenance or repair work.

- Fluids such as fuel or hydraulic oil under pressure can penetrate the skin and eyes causing serious injuries. Take care to avoid these risks when repairing or doing maintenance work on the vehicle.
- Discharge the pressure (using the hydraulic levers of the distributors) before disconnecting or repairing pipes and hydraulic parts.



- DANGER

When a hydraulic pipe needs to be disconnected, slowly loosen the fittings to discharge residual pressure.

**- PRESSURISED LIQUIDS DANGER**

Hydraulic energy accumulators are mounted on the vehicle. Before intervening on them, make sure to discharge any internal pressure. Danger of high pressure oil squirts.

- Before restarting the engine, ensure that all connections have been properly tightened.
- Use a piece of cardboard to check for any leaks; make sure your hands and body are adequately protected against pressurised fluids.
- Any fluids that penetrate the skin must be removed surgically. Should there be an accident, seek medical attention immediately.

**- FORBIDDEN**

Never touch air conditioning coolant.

- If it comes into contact with eyes, air conditioning coolant may cause blindness; it may cause freezing if it comes into contact with skin.
- When cleaning with compressed air, serious injury may be caused by flying particles.
- Always wear protective goggles, a dust mask, gloves and other protective equipment.

**- ATTENTION**

adjusting and/or dismantling balancing and safety valves can be dangerous.

One of the above-mentioned valves may be removed only when the concerned jack is at rest and the hydraulic circuit is not under pressure.

All other operations must be carried out by qualified, authorised personnel only.

**- NOTE**

Only use lubricants suggested by DIECI never utilise used lubricants.



11.2 Preliminary maintenance operations

11.2.1 Prepare the vehicle for maintenance



- ATTENTION

Before performing maintenance work on your vehicle, do the following:

- Park the vehicle on flat, even ground.
- Engage the parking brake.
- Lower and fully retract all mobile parts (booms, shovels, etc.).
- If the maintenance operation requires the mobile parts to remain up, apply the safety run.
- Run the engine at a minimum for 60 seconds to cool it down.
- Discharge residual pressure from the hydraulic circuit.
- Switch off the key in the ignition switch.
- Remove the ignition key.
- Hang up a sign that indicates maintenance work is underway. This sign can be hung on the cab door and inside the controls.
- Set up barriers and spacers to prevent unauthorised personnel from approaching the vehicle.
- Disconnect the battery isolator switch.
- Allow the engine to cool down.

11.3 Maintenance operations



- CAUTION

Before performing any maintenance operations set the machine in the maintenance position.



- CAUTION

Use appropriate personal protective equipment during the various checking and maintenance operation of the vehicle.

11.3.1 Engine hood opening

To open the engine hood, use the handle and lift the hood to its maximum opening possible.

Turn the safety rod (Fig. 1-M0300, pos.1) 180° to lock the hood in the open position.

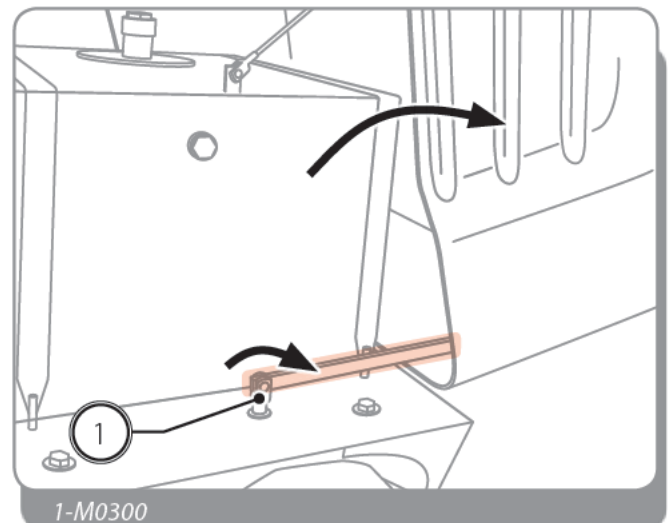



11.3.2 Drive shafts: Lubrication

Lubricate the points indicated in the figure (Fig. 2-M0300) until the grease comes out.



- WARNING

Check the tightening of nuts and bolts on the coupling flanges of the shafts.

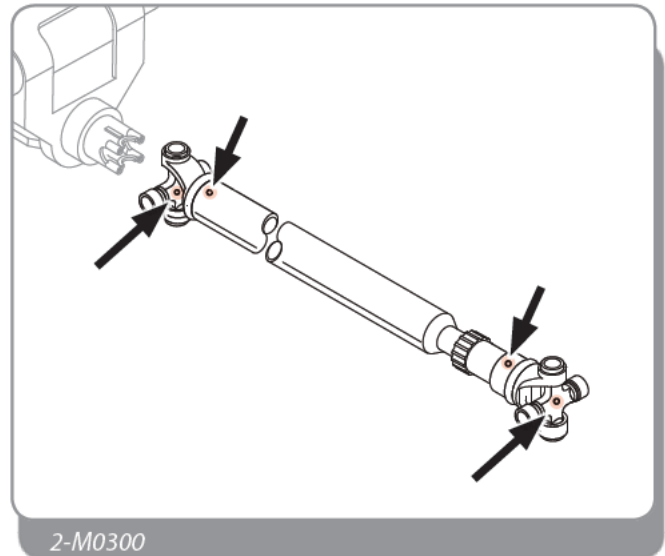

11.3.3 Mechanical joints: Lubrication

Lubricate the points shown in the figure (Fig. 2-M0300 and Fig. 4-M0300) until grease comes out and clean the lubricators from dirt or deposits.

* = only on L3500 and L4700

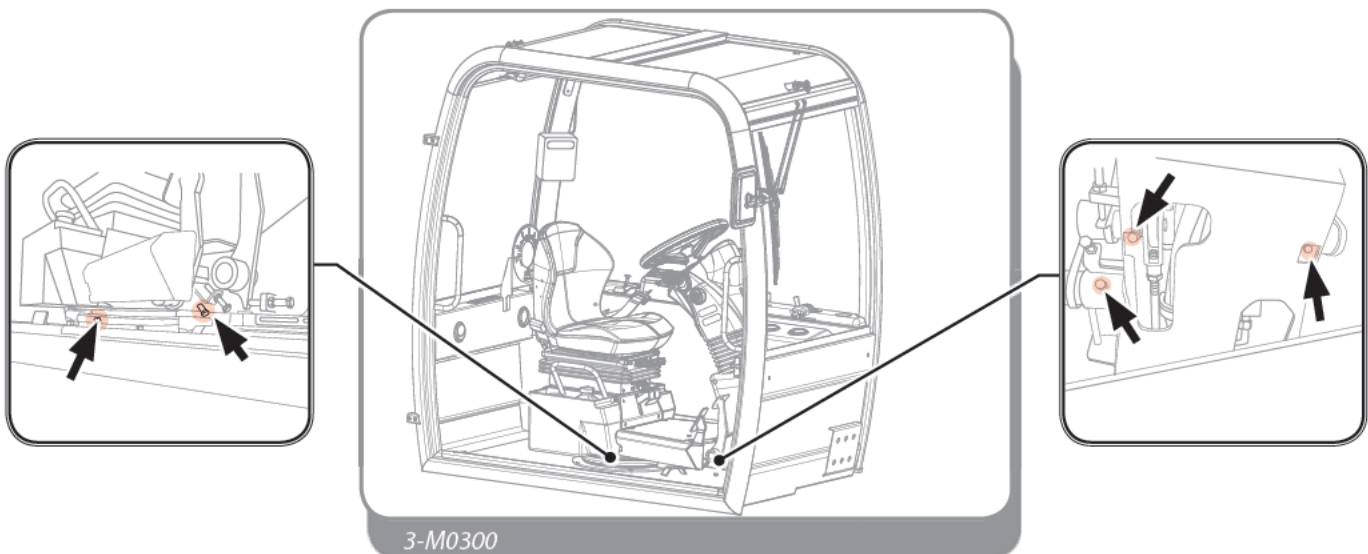

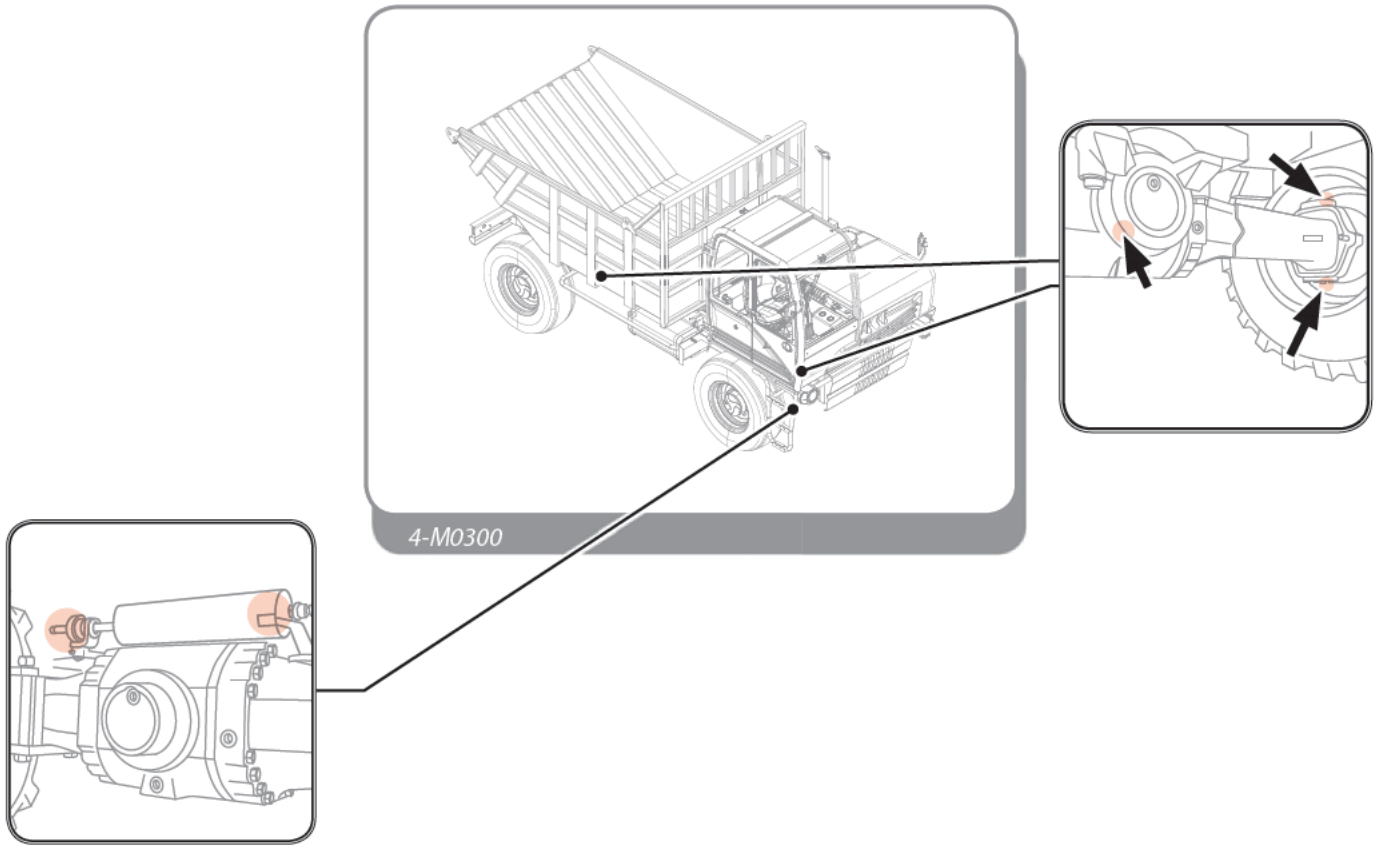

11.3.4 Belts: Check and adjustment

Check that the belt (Fig. 5-M0300) does not have cuts, cracks or rubbing signs; when in doubt, install a new belt.

Make sure that the belt is properly fit on the pulleys and that the tensioner is working properly.



- WARNING

If the belt does not appear in good condition, replace it with a new one

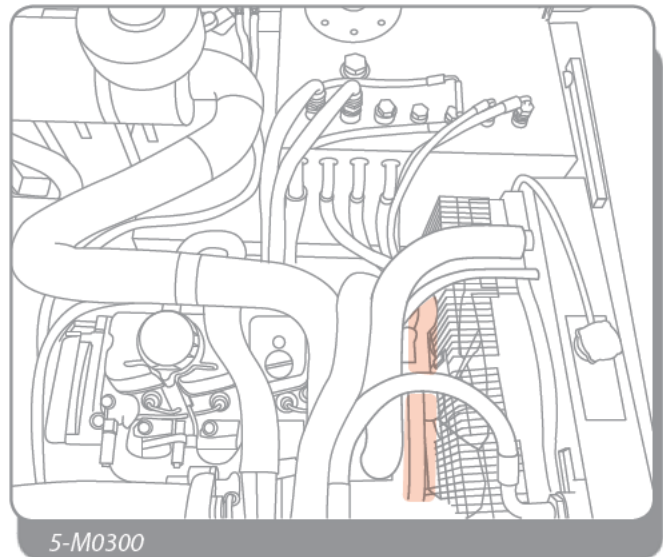

11.3.5 Air conditioning system: Checking and cleaning

Clean the radiator of the air conditioning system (Fig. 6-M0300) from dirt and impurities accumulated between the cooling fins. For cleaning, use compressed air or pressure washer with pressure not exceeding 7 bar.

Check that the fins are not deformed; in that case straighten with caution.

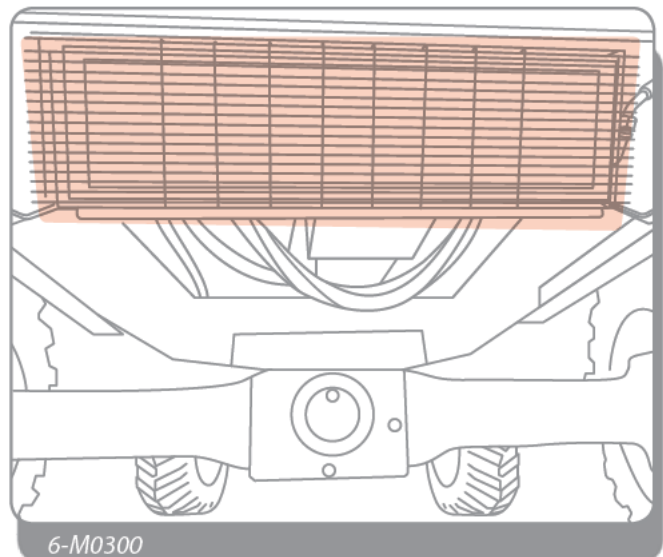

11.3.6 Bolts tightening torque: Adjustment



See the chapter "Nuts and bolts tightening torque" to know the tightening torque for the nuts and bolts of the machine.

11.3.7 *Hydraulic fittings tightening torque: Adjustment*



See the chapter "Hydraulic fittings tightening torque" to know the tightening torque for the hydraulic fittings of the machine.

11.3.8 *Safety stickers: Inspection*

Check that all safety stickers are intact and in good condition.



Refer to the chapter "Safety Stickers Cleaning" for cleaning the safety stickers.

11.3.9 *Cab ventilation filter: Cleaning and replacement*

Remove the cab ventilation filter (Fig. 7-M0300) and remove the filter cartridge for cleaning or replacement.

Clean the filter cartridges by tapping gently on a flat surface, with the outer side facing down, being careful not to damage it; or use a jet of air (less than 6.9 bar) by blowing from the inside to the outside.



- WARNING

Do not use diesel fuel, gasoline, solvents or water to clean the cartridges, as this may damage the filtering material.

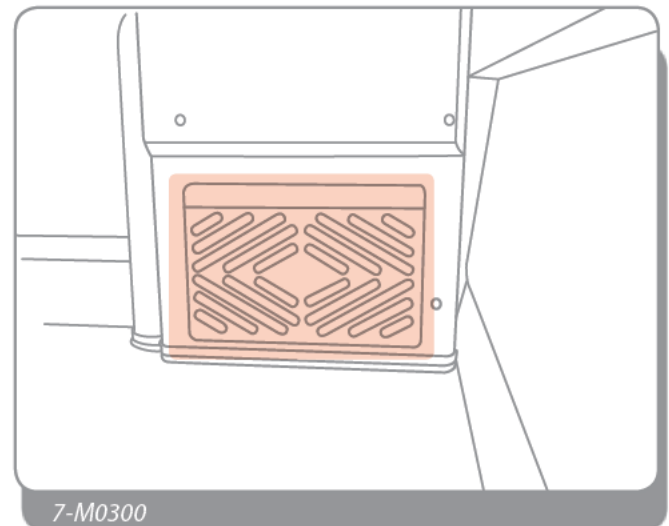

7-M0300

11.3.10 Fuel filter: Replacement



Refer to the engine manual for the fuel filter replacement operations.

11.3.11 Engine oil filter: Replacement



Refer to the engine manual for the operations to replace the engine oil filter.

11.3.12 Hydraulic oil filter: Replacement

To replace the hydraulic oil filter (Fig. 8-M0300) carry out the following operations:

1. Prepare the machine in the maintenance position.
2. Place a container under the oil filter "1" to collect the oil that may spill during the change.
3. Remove the safety clamp "2" from the valve located before the filter.
4. Close the valve "3" to stop the oil flow.
5. Replace the filter "1", lightly oil the gasket and tighten by hand for 3/4 of a turn.
6. After reassembling the filter, open the valve again.
7. Fasten the valve with a new clamp, as done previously.

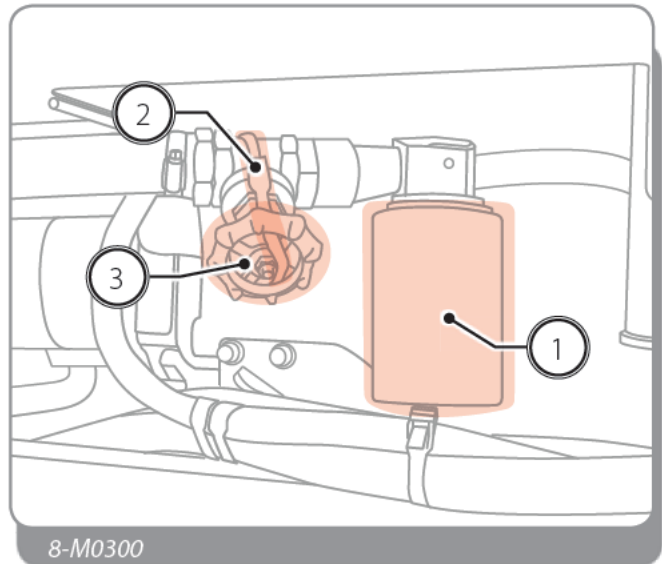

11.3.13 Hydraulic oil intake filter: Replacement

The hydraulic oil intake filters (Fig. 9-M0300, pos. 1) are located inside the hydraulic oil tank; to replace them, completely empty the tank. It is therefore advisable to carry out the replacement of the intake filters in conjunction with the oil change.

To replace the intake filter, carry out the following operations:

1. Prepare the machine in the maintenance position.
2. Move the hydraulic control levers in order to relieve pressure from the tubes.
3. Place a container under the drain plug (located under the tank).
4. Remove the filler cap "2".
5. Remove the drain plug to let the oil drain "3".
6. Remove the flange on which is mounted the filler cap "4" in order to access the intake filters.
7. Unscrew the intake filters located inside the tank with an adjustable spanner.
8. Install new filters and tighten with a wrench.
9. Put back the drain plug "3".
10. Fill the tank with the oil indicated.
11. Check the level through the indicator "2" after starting the engine and operated all hydraulic controls to remove air bubbles, if any.
12. If necessary, top up the level.

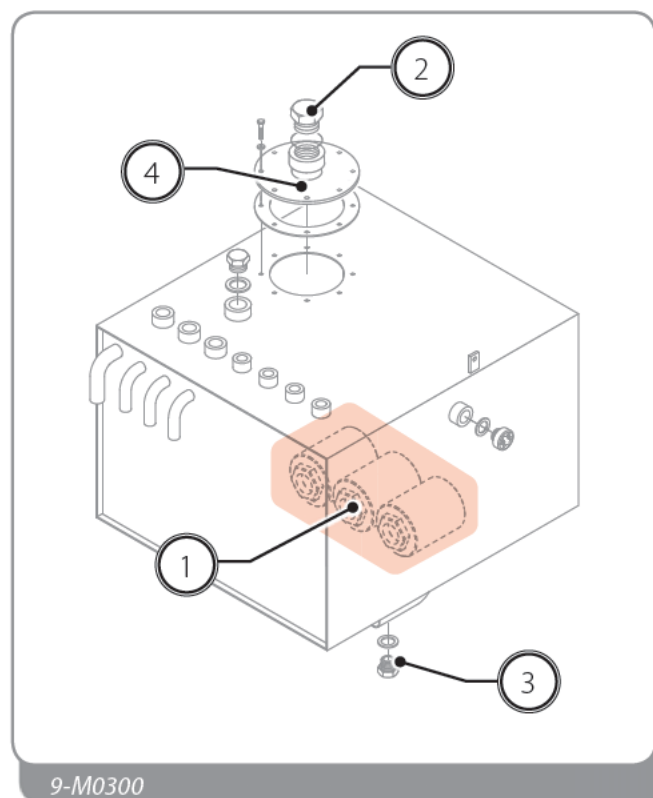

11.3.14 Brake: Inspection

Visually check that the joints of the pedals (Fig. 10-M0300) are not damaged.



- CAUTION

If irregularities in braking are noticed, contact qualified personnel to verify the cause of the trouble.

The braking parts also safeguard the operator's safety, it is recommended not to intervene personally on the hydraulic system trying to eliminate possible anomalies

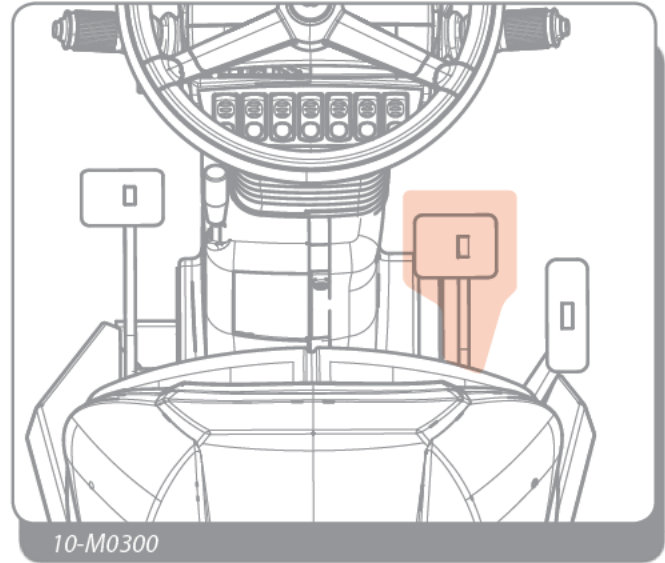

11.3.15 Brakes oil: Check and replacement

When the "Parking brake insufficient pressure" indicator light turns on the central instrument, it means that the brake fluid level has dropped below the minimum (MIN) and therefore it must be restored.

Check that the oil level is always above the minimum level (MIN) marked on the tank. If necessary top up from the cap.



- CAUTION

If the light stays on even after adding oil, contact a Dieci authorized service center to solve the problem.

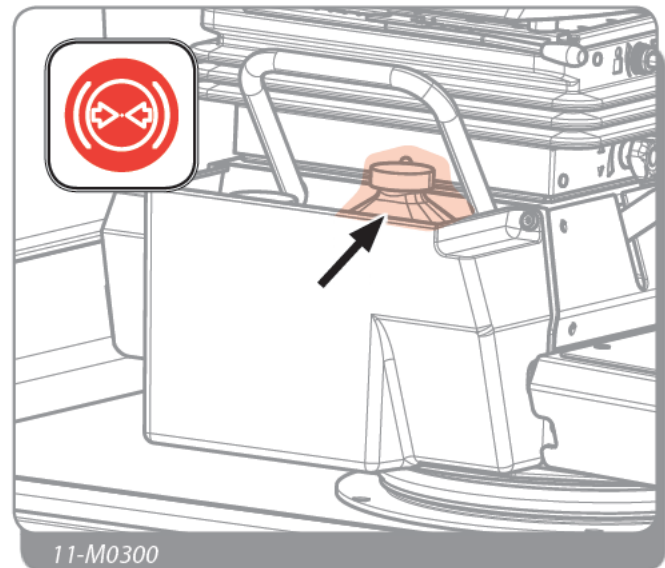

11.3.16 Lights: Inspection

To avoid blinding drivers coming in the opposite direction, make sure that the light beam emitted by the various headlights is properly oriented and adjusted.



Refer to the "Lights" chapter for the replacement and adjustment procedure

11.3.17 Hydraulic oil: Check and replacement

Oil check

To keep the machine in normal operation conditions, it is necessary to keep the oil level in best conditions.

To properly check the oil level in the tank (Fig. 12-M0300) it is necessary to:

1. Prepare the machine in the maintenance position.
2. Check the oil level through the transparent indicator "1". Under the best conditions, the oil level reaches the middle of the transparent indicator.
3. If necessary, remove the cap "2" and add oil until it reaches the proper level.

Oil and oil intake filters change

To change the oil in the tank (Fig. 13-M0300) it is necessary to:

1. Prepare the machine in the maintenance position.
2. Move the hydraulic control levers in order to relieve pressure from the tubes.
3. Place a container under the drain plug (located under the tank).
4. Remove the filler cap "1"
5. Remove the drain plug to let the oil drain "2".
6. Put back the drain plug "2".
7. Fill the tank with the oil indicated
8. Check the level through the indicator "3" after starting the engine and operated all hydraulic controls to remove air bubbles, if any.
9. If necessary, top up the level.



See the chapter "Technical data" to know the amount of oil required and the "oils comparison table" to know the type of oil recommended.

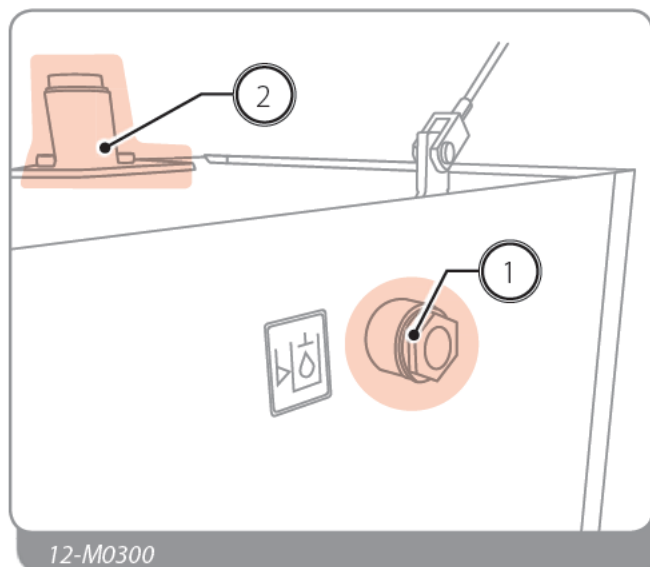

12-M0300

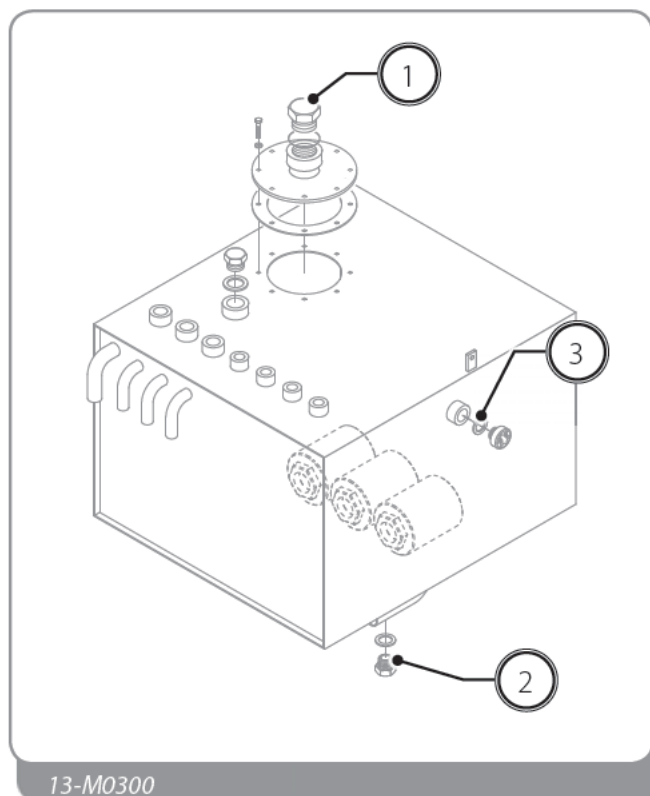

13-M0300

11.3.18 Engine oil: Check and filling up

1. Check the level with the machine on level ground and the engine turned off. Wait at least 5 minutes to allow the oil to settle into the sump.
2. Pull out the dipstick (Fig. 14-M0300), clean it and insert it back fully down.
3. Pull out again the dipstick and check that the oil level is between the "MIN" and "MAX" mark.
4. Put back the dipstick and insert it fully down.
5. If necessary, add oil from the cap on the engine (Fig. 15-M0300).



For the amount and type of oil, refer to the engine manual.



- WARNING

Do not fill beyond the "MAX" mark; if the amount is excessive, oil burns with production of smoke and gives the false impression of oil consumption.



- CAUTION

Never operate the engine with the oil level below the "MIN" mark.

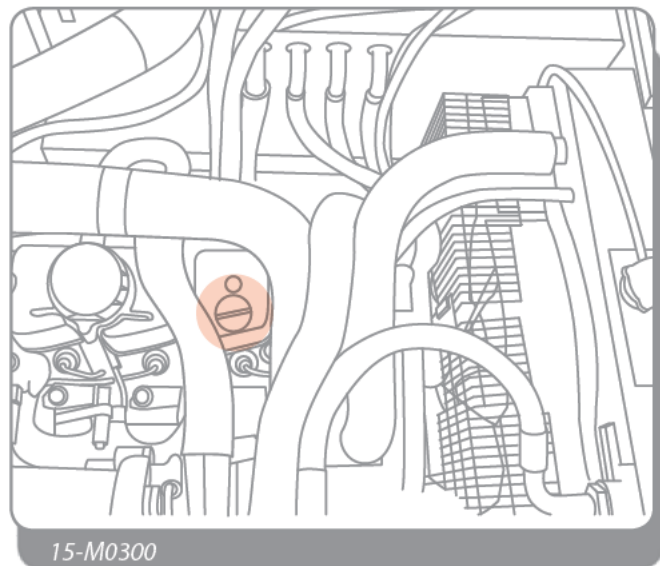
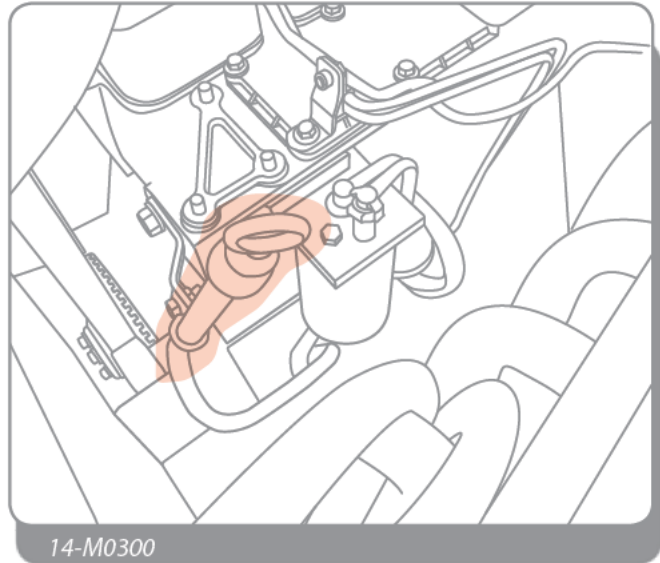

11.3.19 Radiator: Check, cleaning and filling up



- RISK OF BURN

Do not remove the filler cap of the radiator when the system is hot, otherwise it could cause leakage of boiling coolant. Once the system has cooled, turn the filler cap to the first mark and wait until the pressure has completely exhausted before proceeding. Risk of burns and injuries.



- DANGER HARMFUL SUBSTANCES

The coolant can be toxic. Avoid contact with skin, eyes or clothing. Rinse thoroughly with water in case of contact with skin and eyes. Consult a doctor immediately. If not reused, dispose of in accordance with local environmental regulations.

The radiator (Fig. 16-M0300) involves the following operations:

Inspection

Check that the fins are not deformed; in that case straighten with caution.

Check that the fins have not accumulated dirt and that they are not obstructed.

Cleaning

Clean the radiator from dirt and impurities accumulated between the cooling fins. For cleaning, use compressed air or pressure washer with pressure not exceeding 7 bar.

If necessary, apply a detergent solution and then remove it with a pressure washer.

Filling up

1. Remove the filler cap (Fig. 17-M0300)
2. Add coolant to fill the radiator
3. Put back the cap.

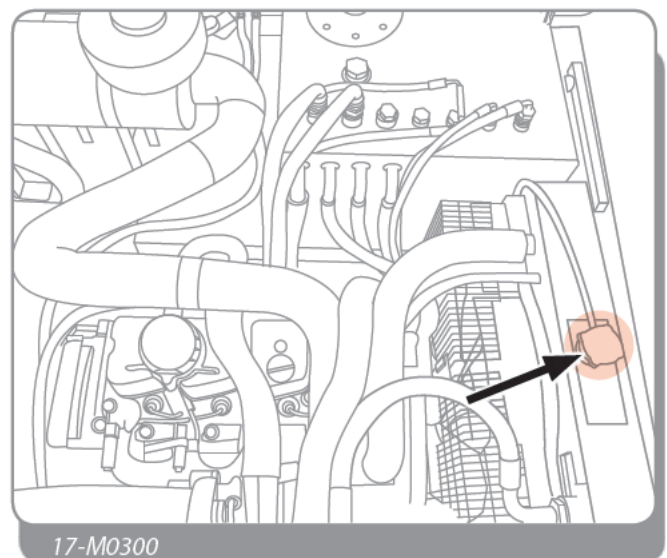
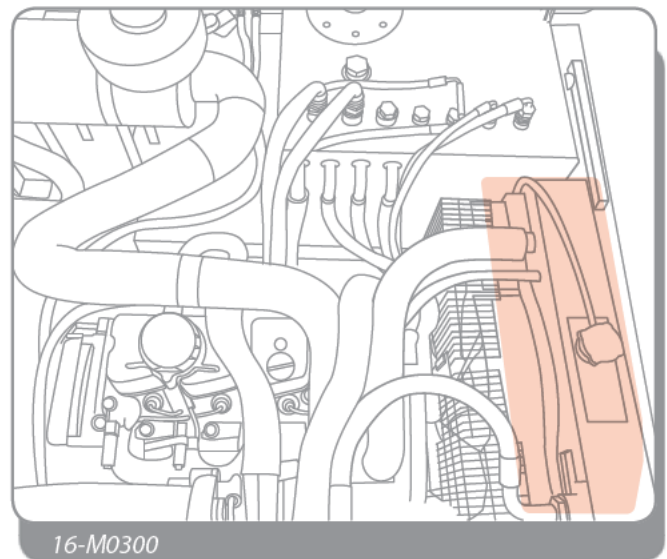



11.3.20 Window washer tank: Filling up

To fill the window washer tank (Fig. 18-M0300) it is necessary to:

1. Remove the filler cap.
2. Add washing fluid to fill the tank.
3. Put back the filler cap.



- WARNING

During the winter, mix antifreeze fluid to the water

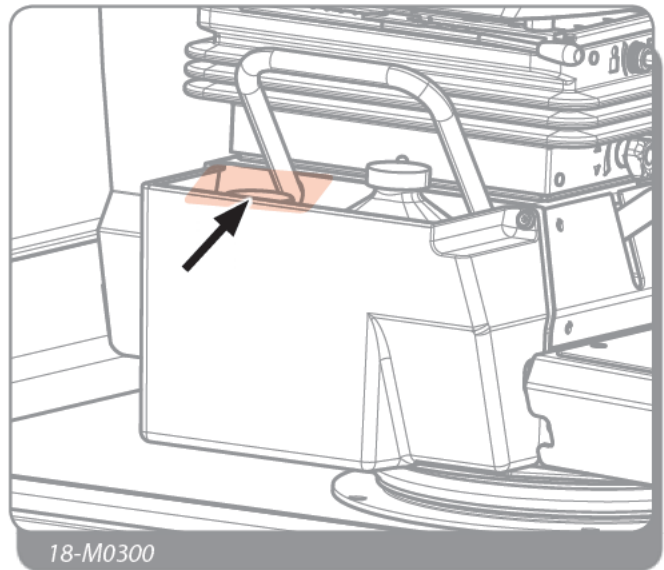

11.3.21 Air filter: Cleaning and replacement



- CAUTION

The inspection, cleaning and replacement must be carried out with the machine in the maintenance position.

An air filter (Fig. 1-M04-00, pos.1) in bad conditions causes reduction of power, excessive fuel consumption and reduced engine life.

The filter clogging is shown by an optical indicator on the filter (Fig. 1-M04-00, pos.2) or if the corresponding light on the instrument panel turns on.

When the indicator remains locked in the red position, it is necessary to perform maintenance or replacement, because clogged.

After performing the necessary interventions press the upper side of the indicator to set it back in the rest condition.



- CAUTION

When the clogging is indicated, it is possible to continue working for not more than one hour.



- WARNING

It is recommended to:

- Clean the filters only when the indicator light indicates clogging or at the frequency required. Unnecessary and too frequent cleaning exposes the elements to damage by handling that can allow dust and dirt to pass through the filtering stage and cause engine damage.
- In case the filter elements are in contact with liquids of any kind they must be replaced.
- Periodically check the tightness of the bolts and clamps. Air must not be allowed to get into the engine circulation without having first gone through the filter.

For the complete efficiency of the filter it is recommended to operate with the filter complete with all its parts and components, assembled in the correct way.

Each deteriorated part must be replaced as soon as possible.

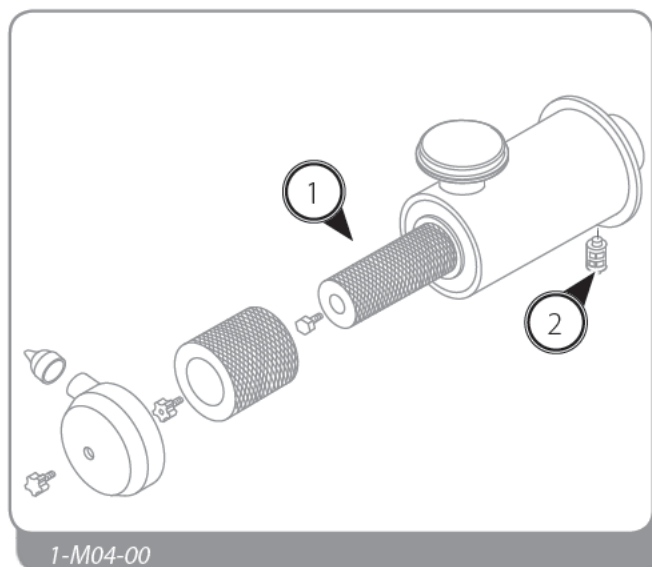

Air filter disassembly

With the machine in the maintenance position, carry out the following operations (Fig. 2-M04-00):

1. Unscrew the knob "1" clockwise and remove the cover "2".
2. Remove the knob "3" screwing it counterclockwise to extract the pre-filter "4".
3. Remove the pre-filter "4".
4. Disassemble the filter "6" from the casing by loosening the bolt "5".
5. Clean or replace the filters and reassemble all performing the same operations in reverse, taking care to not tighten bolts and knobs with excessive force.
6. During the cover "2" assembly, the valve "7" must always be positioned in the lowest part compared to the filter. Otherwise the expulsion functionality is compromised reducing the filter life.

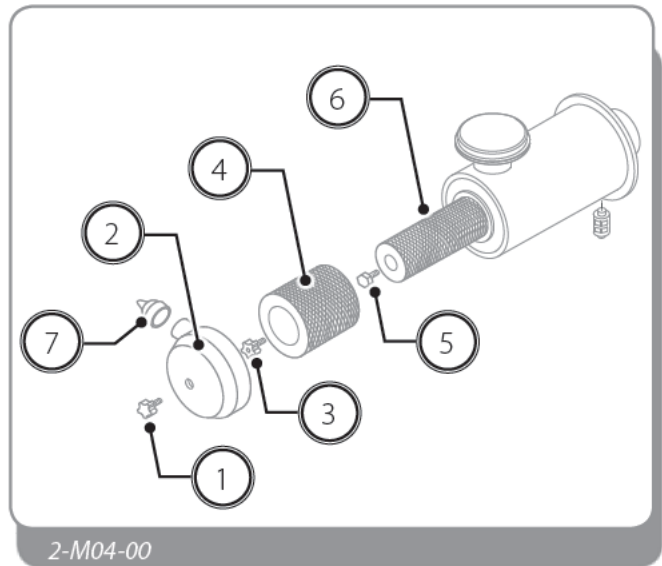

Engine air filter cleaning

The filter cleaning is carried out with compressed air, up to maximum 3 bar, at a distance of not less than 150 mm, taking care not to damage the filtering element.

Use a wet lint-free cloth to clean the sheet metal box and cover.

Engine air filter seal ring replacement

Inside of the joint of the cover there is a sealing ring which prevents air drafts. Because of the atmospheric agents, the rubber of which it is composed, tends to deteriorate, making its replacement necessary when the cracks are formed. To remove it use a small screwdriver; to insert the new gasket place it on its seat and insert it with a little pressure. The seal ring will then be positioned exactly in its seat by refitting the cover.



- WARNING

Do not use screwdrivers or other sharp or pointed tools that may damage the seal during its insertion.

11.4 Transmission maintenance

11.4.1 Oil change: Inspection

1. Set the vehicle in the maintenance position.
2. Place a container under the gearbox.
3. Take the level cap off (Fig. 1-M0410, pos.1), oil must leak out from the hole.
4. If necessary, top-up through the hole of the cap until the oil seeps through.

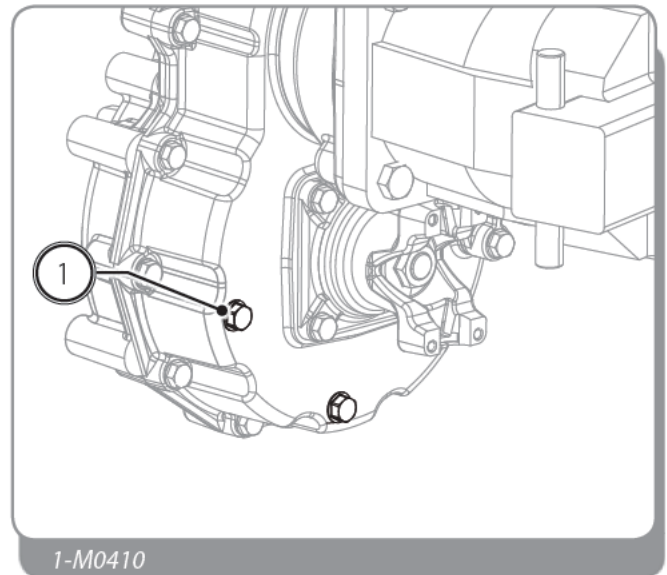

11.4.2 Oil change: Inspection and change

1. Set the vehicle in the maintenance position.
2. Place a container under the gearbox.
3. Take the level cap (Fig. 2-M0410, pos.1) and the drain cap off (Fig. 2-M0410, pos.2).
4. Allow the oil to completely drain out.
5. Refit the drain cap and tighten it securely.
6. Top-up with approved type of oil (pos.1) until the oil seeps through.

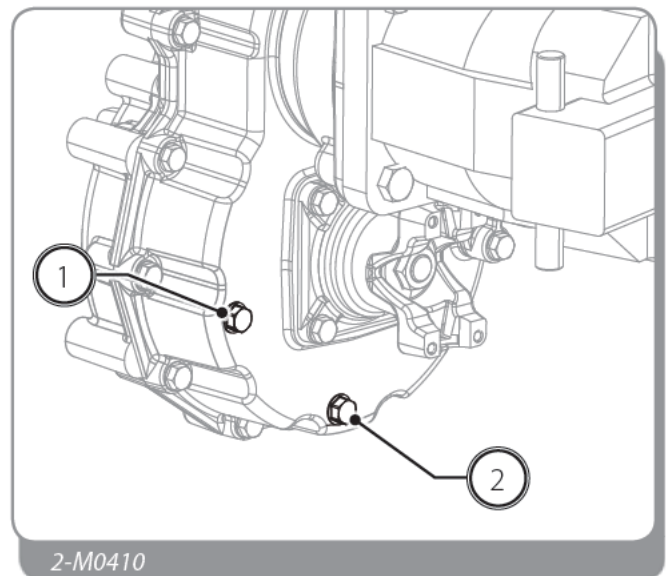

11.5 Wheel maintenance

11.5.1 *Epicycloidal reduction gear oil: Inspection and change*

The oil cap of the epicycloidal reduction gear is located on the hub of the wheel (Fig. 1-M0420):

When checking the oil level:

1. Set the vehicle in the maintenance position.
2. Turn the wheel for the oil cap to be in the horizontal position (9 o'clock).
3. Place a container to collect the oil.
4. Remove the cap and verify that the oil seeps from the hole.
5. If necessary, top-up through the same hole.
6. Close the cap and tighten it securely.

When changing the oil:

1. Set the vehicle in the maintenance position.
2. Turn the wheel for the oil cap to be in the lowest possible position (6 o'clock).
3. Place a container to collect the oil.
4. Remove the cap and let the oil drain completely.
5. Turn the wheel and bring the cap to the horizontal position (9 o'clock).
6. Fill through the same cap with new oil until it seeps through.
7. Close the cap and tighten it securely.

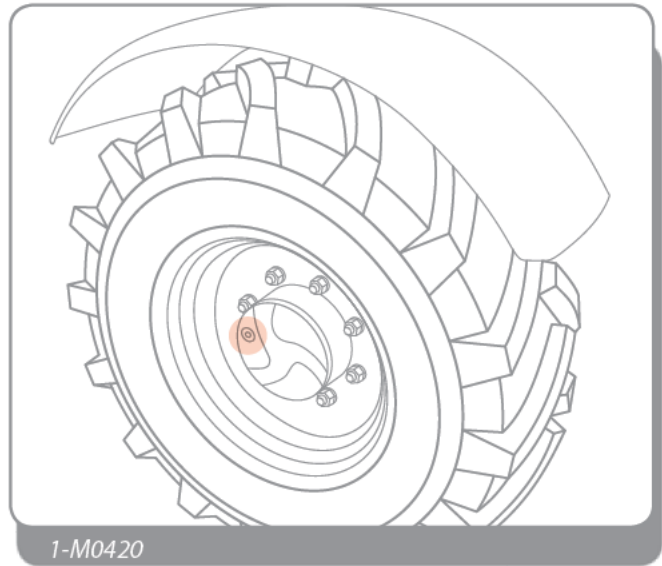

11.5.2 Tyre pressure: Inspection

Verify and adjust the pressure of the front and rear tyres.

Check that the tread and the sides are not damaged.

Connect a manometer to the tyre valve and verify that the inflation pressure is correct.



Adjust the tyre pressure according to the indications provided in the "Tyres" chapter.

11.5.3 Tightness of the wheel nuts: Inspection

Check that the nuts of the front and rear wheels are tightened well, using a torque wrench (with a torque multiplier, if necessary).

Tapered nut	Torque
M18x1,5	460 N/m
M22x1,5	740 N/m

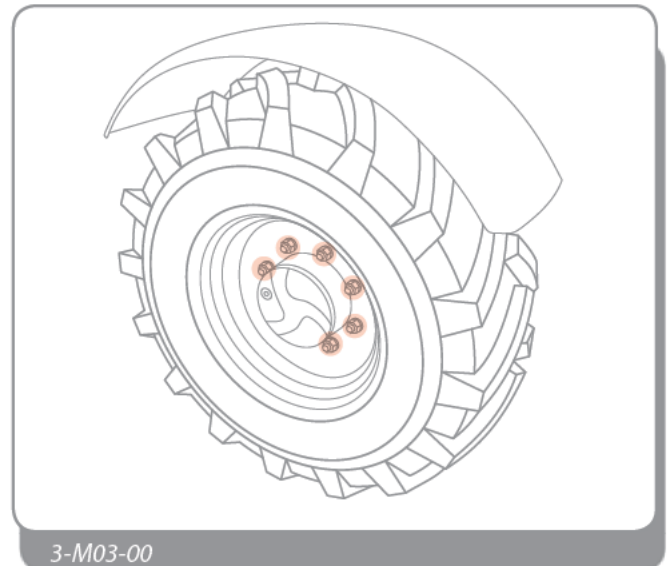
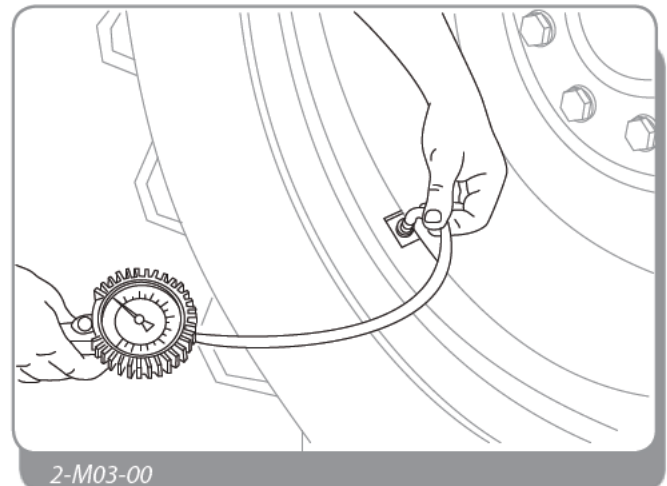

11.6 Differential axle maintenance

11.6.1 Differential axle oil: Inspection and change

The filler, level and drain caps are in the middle part of the front and rear differential axle (Fig. 1-M04-30):

When checking the oil level:

1. Set the vehicle in the maintenance position.
2. Place a container under the level cap "2" to collect any oil that may leak.
3. Open the level cap "2". In optimal conditions, the oil must seep from the hole.
4. If necessary, open cap "1" and top-up until the oil seeps from level cap "2".
5. Close the caps and tighten them securely.

When changing the oil:

1. Set the vehicle in the maintenance position.
2. Place a container under the drain plug "3" to collect any oil that may leak.
3. Open the filler cap "1" and then drain plug "3".
4. Allow the oil to completely drain out.
5. Close the drain plug "3".
6. Fill new oil through the filler cap "1" until the oil seeps from level cap "2".
7. Close the caps and tighten them securely.

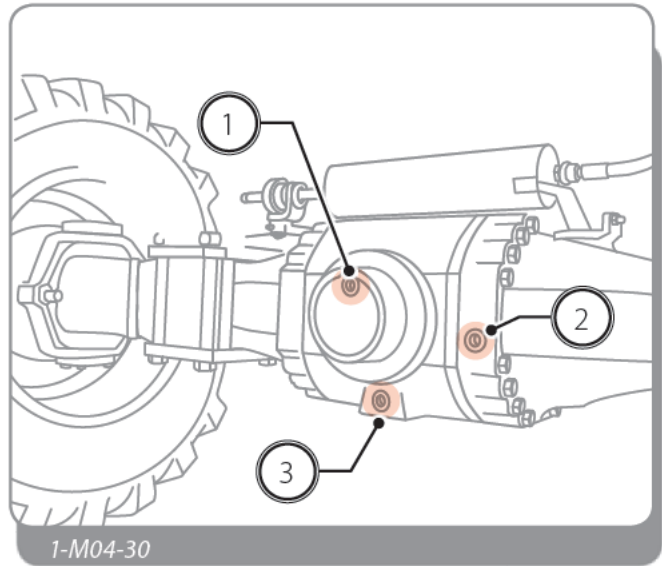

11.7 Bolts tightening torque

11.7.1 Fine pitch

	Coefficient of friction	4.8		5.8		6.8		8.8		10.9		12.9	
		Preload (N)	Tightening torque:(Nm)	Preload (N)	Tightening torque:(Nm)	Preload (N)	Tightening torque:(Nm)	Preload (N)	Tightening torque:(Nm)	Preload (N)	Tightening torque:(Nm)	Preload (N)	Tightening torque:(Nm)
M8	0.10	9798.1	10.87	12247.6	13.59	14697.1	16.31	19596.1	21.75	27557.1	30.58	33068.5	36.70
	0.14	9079.5	13.53	11349.4	16.91	13619.3	20.29	18159.1	27.05	25536.2	38.04	30643.4	45.65
M10	0.10	15296.9	21.13	19121.1	26.41	22945.3	31.69	30593.8	42.25	43022.5	59.42	51627.0	71.30
	0.14	14175.0	26.27	17718.8	32.84	21262.6	39.41	28350.1	52.55	39867.3	73.89	47840.8	88.67
M10	0.10	16383.6	22.12	20479.5	27.66	24575.4	33.19	32767.2	44.25	46078.8	62.23	55294.6	74.67
	0.14	15221.6	27.80	19027.0	34.75	22832.5	41.70	30443.3	55.61	42810.8	78.20	51373.0	93.84
M12	0.10	22020.7	35.83	27525.9	44.79	33031.0	53.75	44041.4	71.67	61933.2	100.78	74319.8	120.94
	0.14	20405.8	44.53	25507.2	55.66	30608.7	66.79	40811.6	89.06	57391.3	125.24	68869.5	150.29
M12	0.10	23333.7	37.26	29167.1	46.57	35000.6	55.88	46667.4	74.51	65626.1	104.78	78751.3	125.74
	0.14	21669.2	46.70	27086.5	58.38	32503.8	70.06	43338.4	93.41	60944.6	131.36	73133.5	157.63
M14	0.10	31610.0	59.04	39512.5	73.80	47415.0	88.57	63220.0	118.09	88903.1	166.06	106683.7	199.27
	0.14	29345.9	73.92	36682.4	92.40	44018.9	110.89	58691.9	147.85	82535.4	207.91	99042.5	249.49
M16	0.10	42581.3	89.78	53226.6	112.23	63871.9	134.67	85162.5	179.56	119759.8	252.51	143711.8	303.02
	0.14	39587.8	113.06	49484.7	141.32	59381.6	169.59	79175.5	226.12	111340.6	317.98	133608.7	381.57
M18	0.10	51457.2	124.03	64321.5	155.03	77185.8	186.04	102914.4	248.06	144723.3	348.83	173668.0	418.59
	0.14	47751.7	155.02	59689.6	193.78	71627.5	232.53	95503.3	310.05	134301.6	436.00	161161.9	523.20
M18	0.10	55415.1	130.17	69268.9	162.72	83122.7	195.26	110830.3	260.35	155855.1	366.12	187026.1	439.34
	0.14	51577.6	164.67	64472.0	205.84	77366.4	247.01	103155.2	329.35	145062.1	463.15	174074.5	555.77
M20	0.10	65534.1	173.72	81917.7	217.16	98301.2	260.59	131068.3	347.45	184314.8	488.60	221177.8	586.32
	0.14	60886.2	218.17	76107.8	272.71	91329.3	327.26	121772.4	436.34	171242.5	613.61	205491.0	736.33
M20	0.10	70114.7	181.58	87643.3	226.97	105172.0	272.36	140229.3	363.15	197197.5	51.68	236637.0	612.82
	0.14	65319.1	230.55	81648.8	288.19	97978.6	345.82	130638.1	461.10	183709.9	648.42	220451.9	778.10
M22	0.10	81220.8	236.88	101526.0	296.10	121831.2	355.32	162441.5	473.76	228433.4	666.23	274120.1	799.48
	0.14	75533.9	298.75	94417.4	373.43	113300.9	448.12	151067.8	597.49	212439.1	840.22	254927.0	1008.27
M22	0.10	86164.2	246.02	107705.3	307.53	129246.4	369.04	172328.5	492.05	242337.0	691.94	290804.3	830.33
	0.14	80331.8	313.41	100414.7	391.76	120497.7	470.11	160663.6	626.82	225933.2	881.46	271119.8	1057.75
M24	0.10	98515.6	308.56	123144.5	385.70	147773.4	462.84	197031.1	617.12	277075.0	867.83	332490.0	1041.40
	0.14	91693.3	390.33	114616.6	487.92	137539.9	585.50	183386.5	780.67	257887.3	1097.82	309464.8	1317.38
M24	0.10	104079.4	319.62	130099.2	399.52	156119.0	479.43	208151.7	639.23	292723.2	898.92	351267.9	1878.71
	0.14	97096.0	408.12	121370.1	510.15	145644.1	612.18	194192.1	816.24	273082.6	1147.84	327699.1	1377.41
M27	0.10	127922.3	448.43	159902.9	560.54	191883.5	627.65	255844.7	896.87	359781.6	1261.22	431737.9	1513.46
	0.14	119185.0	569.67	148981.3	712.09	178777.5	854.51	238370.1	1139.34	335207.9	1602.20	402249.5	1922.64
M30	0.10	16817.5	623.80	201021.8	779.75	241226.2	935.70	321635.0	1247.60	452299.2	1754.43	542759.0	2105.32
	0.14	149957.0	795.14	187446.3	993.93	224935.5	1192.72	299914.0	1590.29	421754.2	2236.34	506105.0	2683.61



11.7.2 Coarse pitch

	Coefficient of friction	4.8		5.8		6.8		8.8		10.9		12.9	
		Preload (N)	Tightening torque:(Nm)	Preload (N)	Tightening torque:(Nm)	Preload (N)	Tightening torque:(Nm)	Preload (N)	Tightening torque:(Nm)	Preload (N)	Tightening torque:(Nm)	Preload (N)	Tightening torque:(Nm)
M3	0.10	1219.9	0.54	1524.9	0.68	1829.9	0.82	2439.9	1.09	3431.0	1.53	4117.2	1.84
	0.14	1125.9	0.60	1407.4	0.83	1688.9	1.00	2251.9	1.34	3166.7	1.88	3800.0	2.26
M3.5	0.10	1638.2	0.84	2047.8	1.05	2457.3	1.26	3276.4	1.68	4607.5	2.36	5528.9	2.84
	0.14	1511.3	1.03	1889.2	1.28	2267.0	1.54	3022.6	2.05	4250.6	2.89	5100.7	3.47
M4	0.10	2115.4	1.25	2644.3	1.56	3173.1	1.88	4230.8	2.50	5949.6	3.52	7139.5	4.22
	0.14	1950.9	1.53	2438.7	1.91	2926.4	2.29	3901.9	3.06	5487.0	4.30	6584.4	5.16
M5	0.10	3461.6	2.46	4327.0	3.08	5192.3	3.70	6923.1	4.93	9735.7	6.93	11682.8	8.32
	0.14	3196.8	3.02	3996.0	3.78	4795.2	4.53	6393.7	6.04	8991.1	8.50	10789.3	10.20
M6	0.10	4874.7	4.24	6093.4	5.30	7312.1	6.35	9749.4	8.47	13710.1	11.92	16452.2	14.30
	0.14	4499.1	5.19	5623.9	6.48	6748.6	7.78	8998.2	10.37	12653.7	14.59	15184.4	17.51
M7	0.10	7134.5	6.97	8918.2	8.71	10701.8	10.45	14269.1	13.94	20065.9	19.60	24079.1	23.52
	0.14	6599.6	8.60	8249.5	10.76	9899.4	12.90	13199.2	17.21	18561.4	24.20	22273.6	29.04
M8	0.10	8947.1	10.20	11183.9	12.75	13420.7	15.30	17894.2	20.41	25163.7	28.70	30196.5	34.44
	0.14	8265.6	12.54	10332.0	15.67	12398.4	18.80	16531.2	25.07	23247.0	35.26	27896.5	42.31
M10	0.10	14244.5	20.11	17805.6	25.14	21366.8	30.16	28489.0	40.22	40062.7	56.56	48075.3	67.87
	0.14	13167.4	24.76	16459.2	30.95	19751.1	31.14	26334.8	49.52	37033.3	69.64	44439.9	83.56
M12	0.10	20766.6	34.43	25958.3	43.03	31149.9	51.64	41533.2	68.86	58406.1	96.83	70087.3	116.20
	0.14	19204.0	42.42	24005.0	53.03	28806.0	63.63	38408.0	84.84	54011.2	119.31	64813.5	143.17
M14	0.10	28389.9	54.77	35487.4	68.46	42584.9	82.15	56779.8	109.53	79846.6	154.03	95816.0	184.84
	0.14	26261.2	67.56	32826.5	84.45	39391.8	101.34	52522.4	135.13	73859.6	190.02	88631.5	228.03
M16	0.10	39242.1	85.14	49052.7	106.43	58863.2	127.72	78484.3	170.29	110368.5	239.47	132442.2	287.36
	0.14	36364.2	105.80	45455.3	132.26	54546.3	158.71	72728.5	211.61	102274.4	297.58	122729.3	357.09
M18	0.10	47533.0	117.48	59416.3	146.85	71299.6	176.22	95066.1	234.96	133686.7	330.41	160424.1	396.49
	0.14	43986.1	145.16	54982.7	181.45	65979.2	217.74	87972.3	290.32	123711.0	402.26	148453.2	489.92
M20	0.10	61238.0	166.08	76547.5	207.61	91857.0	249.13	122476.0	332.17	172231.9	467.11	206678.2	560.54
	0.14	56747.1	206.39	70933.9	257.98	85120.6	309.58	113494.2	412.78	159601.2	580.47	191521.5	696.56
M22	0.10	76305.2	227.22	95381.5	284.02	114457.8	340.82	152610.4	454.43	214608.3	639.05	257530.0	766.85
	0.14	70791.9	283.79	88489.8	352.74	106187.8	425.69	141583.7	567.58	199102.1	798.16	238922.5	957.80
M24	0.10	88232.4	287.16	110290.5	358.94	132348.6	430.73	176464.9	574.31	248153.7	807.63	297784.4	969.15
	0.14	81761.8	356.84	102202.2	446.05	122642.7	535.26	163523.6	713.68	229955.1	1003.61	275946.1	1204.33
M27	0.10	115778.8	420.40	144723.5	525.05	173668.2	930.06	231557.6	840.08	325627.9	1181.36	390753.4	1417.63
	0.14	107441.5	525.08	134301.9	656.35	161162.2	787.62	214883.0	1050.16	302179.2	1476.79	362615.0	1772.15
M30	0.10	140999.5	572.83	176249.4	716.03	211499.3	859.24	281999.0	1145.65	396561.1	1611.08	475873.4	1933.29
	0.14	130770.6	714.49	163463.3	893.11	196155.9	1071.73	261541.2	1428.97	367792.3	2009.49	441350.8	2411.39

11.8 Hydraulic fittings tightening torques

Inserts with 60° nose - BSP thread									
Thread	1/18.28	1/4.19	3/8-19	1/2-14	5/8-14	3/4-14	1"-11	1"1/4-11	121/2-11
(Nm)	12-14	14-16	25-28	45-60	55-70	90-110	120-140	170-190	200-245

Inserts with 60° nose - METRIC thread									
Thread	10x1	12x1.5	14x1.5	16x1.5	18x1.5	22x1.5	26x1.5	28x1.5	30x1.5
(Nm)	12-14	13-15	15-18	25-28	27-30	50-60	60-75	80-100	110-130

SERIES DIN RANGE "L"										
Thread	12x1.5	14x1.5	16x1.5	18x1.5	22x1.5	26x1.5	30.2	36x1.5	45x1.5	52x1.5
(Nm)	13-15	15-18	25-28	27-30	50-60	30-75	85-105	120-140	170-190	190-230

SERIES DIN RANGE "S"										
Thread	14x1.5	16x1.5	18x1.5	20x1.5	22x1.5	24x1.5	30x2	36x2	42x2	52x2
(Nm)	15-18	25-28	27-30	43-54	50-62	60-75	90-110	125-145	170-190	200-245



12 TECHNICAL SERVICE CENTRE

12.1 Spare parts supply

DIECI S.R.L. guarantees the supply of original spare parts or alternatives for 10 years, starting from the date of the last manufactured model in the relative range.



In addition to this use and maintenance manual, every Dieci vehicle or equipment is supplied with a spare parts catalogue so as to be able to order all the parts required for repairs.

12.2 Assistance provided to the owner/ operator

Take note of this important information before contacting the service centre in order to obtain optimum service from your Dealer.

1. Specify your name, address and telephone number.
2. Quote the model and chassis serial number of the vehicle.
3. Quote the purchase date and operating hours.
4. Describe the type of fault.

Only DIECI Dealers have access to DIECI customer service resources. Moreover, Dealers can offer a variety of programmes regarding guarantee, fixed rate maintenance and safety checks, including tests.



Dieci Technical Assistance Service

Via E. Majorana, 2/4

42027 Montecchio Emilia (RE) ITALY

Tel. +39 0522 869611

Fax +39 0522 869744

service@dieci.com

12.3 Problems diagnostics



The interventions for the elimination of faults can only be carried out by trained personnel.

Do not work on failures if the "Safety regulations", "Safe Working Procedures" and "MAINTENANCE" have not been read and understood before.





This symbol indicates that the trouble experienced may NOT be resolved without the intervention of a DIECI Service authorized workshop

12.3.1 Engine

Problem	Cause	Solution	
It does not set in motion	Operator not sitting in driver position correctly	Sit correctly in the cab	
	Direction of travel lever engaged	Place the lever in neutral	
	No fuel	Fill the tank	
	Battery cut-off switch disconnected	Connect the battery cut-off switch	
	Low Battery	Recharge the battery or replace it	
	Fuse failure	Replace the fuse	
	Other	Consult the Use and Maintenance manual of the engine	

12.3.2 Hydraulic transmission system



Problem	Cause	Solution	
The machine does not go in any direction	The sensor in the seat does not detect the driver's presence	Sit correctly in the driver's seat	
	The forward/backward lever is not engaged (indicator light off)	Engage the lever to the desired position	
	Fast/slow speed not engaged (indicator light off)	Press the speed consent button	
	Insufficient hydraulic oil level	Check the hydraulic oil level	
	Parking brake in operation	Disengage the brake	
	Hydrostatic transmission failure	Repair or replace the transmission	
	Electrical circuit failure	Repair the circuit	
	The ByPass valve under the vehicle is closed (machine towing)	Open the ByPass valve	
	Hydraulic oil suction filter clogged	Remove the oil filter and replace it	
	Filter valve closed	Open the valve	

Problem	Cause	Solution	
The vehicle loses speed	Hydraulic oil suction filter clogged	Remove the oil filter and replace it	
	Hydrostatic transmission failure	Repair or replace the transmission	
	Diesel engine failure	Consult the Use and Maintenance manual of the engine	
	Fuel filter	Remove the oil filter and replace it	
	Air filter	Remove the oil filter and replace it	

12.3.3 Brakes

Problem	Cause	Solution	
The machine does not brake	Loss of fluid from the circuit	Check for leaks	
	Brake discs worn	Replace the brake discs	
	Brake system failure	Repair or replace	

12.3.4 Steering wheel

Problem	Cause	Solution	
The machine runs sideways, the wheels are not aligned	The wheels are not correctly aligned	Proceed with alignment	
	Steering selection error	Select a different steering mode	
	Steering system failure	Repair or replace the distributor	
	Leakage from the steering wheel hydraulic cylinders	Replace the gaskets	

13 CLEANING

Cleaning the vehicle and all its components is fundamental for it to be kept in proper working order.

13.1 Cleaning the vehicle

Proceed as follows for a correct cleaning process:

- Switch the engine off, remove the ignition key and wait until the various components cool down.
- Wear the suitable protective clothing (gloves, masks, overalls, etc.).
- Do not use flammable liquids, acids or products that may chemically attack the vehicle components.
- Use water to soften dirt that sticks to the surface.
- Ask your **DIECI** dealer for touch-up paint to repair minor defects in the vehicle's bodywork.
- Check that all the safety stickers are present. Replace any that have been lost or removed for cleaning purposes.
- Use a pressure washer to clean the external part of the vehicle and the engine compartment, bearing the following in mind:
 - Make sure the top-up caps (radiator, oil tank, fuel tank, etc.) are closed well.
 - Protect the control boxes and connectors from water infiltrations.
 - Do not operate with a pressure and water temperature that exceeds 100 bar and 80°, respectively.
 - Hold the washer nozzle at a minimum distance of 40 cm from the relative surface.
 - Do not direct the jet at any single point but wash with wide strokes.
 - The inside of the vehicle is delicate and cannot be cleaned with a pressure washer.



- FORBIDDEN

Cleaning the stickers on the vehicle with solvents or petrol is strictly forbidden as the stickers may fade. Additional warning and safety stickers must always be treated in the same way.



- ELECTRICAL COMPONENTS

- If a pressurised jet is used, try not to wet the electrical components, such as the alternator and the starter motor.
- If water accidentally falls into the electrical system, it could cause the vehicle to malfunction.
- Do not use water or steam to clean the electrical system, sensors or connectors.



- MECHANICAL COMPONENTS

- Do not clean moving or overheated parts. Let the parts cool down as a temperature excursion may damage them.

13.2 Washing the windows

- The cab windows, lights and rear view mirrors must be washed often with soapy water.
- After washing has been completed, dry thoroughly; do not leave any stains or marks which may limit or obstruct the driver's visibility.

13.3 Cleaning the cab

- Clean soft upholstery in the cab with a cloth that has been dipped in a solution of water and detergent and then thoroughly wrung.
- The driver's seat and the floor must be cleaned with a vacuum cleaner and/or a stiff brush. If necessary, use a damp cloth to remove any stubborn stains.
- Clean the seat belt with a sponge that has been soaked in hot soapy water, and let it dry on its own.
- Fabric-covered seats must be cleaned with a stiff brush or vacuum cleaner. Plastic seats must be cleaned with a damp cloth.



- ELECTRICAL COMPONENTS

Do not use water jets inside the cab.



- FORBIDDEN

Do not use products containing alcohol to clean the interior lining of the cab.

13.4 Cleaning of the safety stickers



- ATTENTION

To ensure correct interpretation, verify that they are located in the correct position and that they are always kept clean.



- DANGER

Clean the stickers if they are covered by dirt, cement or other deposits.



- FORBIDDEN

Cleaning the stickers on the vehicle with solvents or petrol is strictly forbidden as the stickers may fade. Additional warning and safety stickers must always be treated in the same way.

14 LIFTING, TRANSPORT AND STORAGE

14.1 Machine lifting



- DANGER

Always check the good condition of the anchors (ropes, chains, wedges, etc...).



- CAUTION

Make sure that the lifting equipment is adequate for the weight of the machine to be lifted.

The weight of the machine is shown on a special riveted metal plate; check the overall dimensions for the maximum and minimum height values from the ground and the weight allowed.

The vehicle is fitted with lifting points, marked by special symbols (Fig. 1-R0000).

Attach the ropes at the points indicated in the figure, paying utmost attention during the lifting phases. Slowly proceed with the lifting.



- DANGER

Before lifting the vehicle, make sure no unauthorized personnel are in the surrounding area.



- CAUTION

Lifting cables with a minimum unit capacity of 6 Tonnes are required.

Before lifting the vehicle, make sure to:

- Remove any attachments installed on the vehicle.
- Engage the parking brake, place and the movement selection lever at "N" and switch off the vehicle.
- Close all windows and the cab door (if installed).

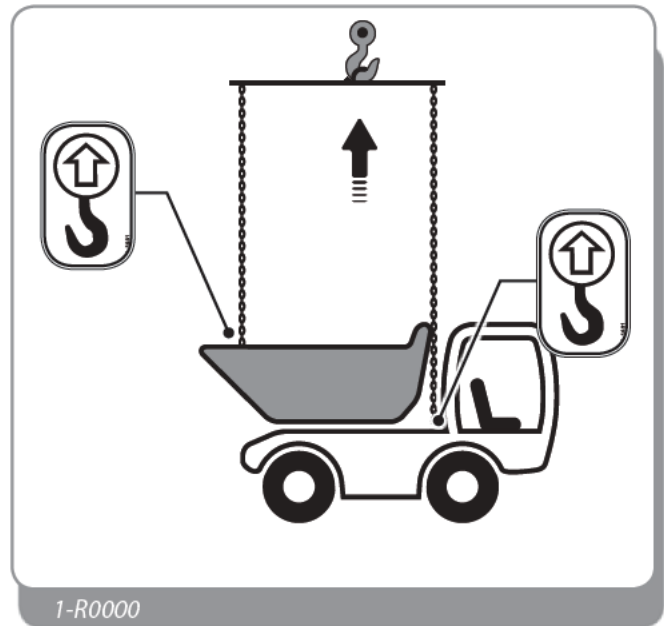

14.2 Transporting the vehicle

14.2.1 Transporting the vehicle on a trailer



- DANGER

Always check the good condition of the anchors (ropes, chains, wedges, etc...).



- CAUTION

Pay attention to the following when loading the vehicle onto a trailer:

- Before using ramps or trailers to load the machine on, remove any mud, ice or oil that could cause accidents.
- Check that the axle and the transport vehicle can withstand the overall weight of the machine and any loaded equipment.
- Check the overall dimensions of the vehicle for minimum and maximum heights from the ground and the weight allowed.
- Carefully operate the machine onto the transport vehicle.
- Make sure local regulations are observed when transporting the vehicle on public roads.



- DANGER

When loading or unloading a vehicle from a transport vehicle, there is always the risk of the vehicle overturning sideways; therefore, have another person on the ground to control the operations.

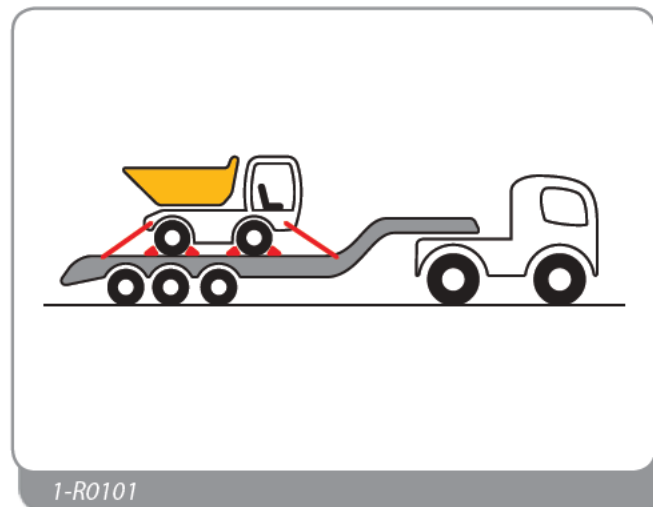

Take the following precautions when loading or unloading a vehicle:

1. Choose solid and level ground.
2. Remove any attachments installed on the vehicle.
3. Lower and completely retract the telescopic boom
4. Use a platform or a ramp.
5. Always select the slowest speed.
6. Load the vehicle on to the transport vehicle, making sure that the ramps are positioned properly and safely.
7. Once the vehicle is in a safe position, switch the engine off and engage the parking brake.
8. Close all windows and the cab door (if installed).
9. Anchor the vehicle to the transport vehicle with chains or cables through the relative hooks (Fig. 2-R0101).
10. Apply wedges to the front and rear wheels of the transport vehicle.



15 STORING THE VEHICLE

15.1 Long period of inactivity

If the vehicle must be stored for a long period of time (over a week), certain precautions must be complied with to protect it:

- Clean the vehicle.
- Lubricate all the greasers.
- Check the tires and inflate them to the recommended pressure.
- Clean the fuel system and change the filter cartridges.
- Store any equipment.
- Use the battery cut-off switch to deactivate the electrical circuit.
- Realign and lower all the mobile parts of the vehicle completely.
- Close and lock all the windows.
- Close and lock the door.

15.2 Long period of inactivity

If the machine must be stored for a long period (more than two months), certain precautions must be complied with to protect it:

- Clean the vehicle.
- Touch up the paint where necessary to prevent rust.
- Lubricate all the greasers.
- Check whether any parts are worn or damaged and replace them, if necessary.
- Check the tires and inflate them to the recommended pressure.
- Drain the oil from the engine and replace it with new oil.
- Clean the fuel system and change the filter cartridges.
- Empty the fuel tank as usual and fill it with ten liters of special fuel for prolonged inactivity. Run the engine for ten minutes so the new solution can distribute evenly.
- Store any equipment.
- Use the battery cut-off switch to deactivate the electrical circuit.
- Realign and lower all the mobile parts of the vehicle completely.
- Apply a layer of light grease on the uncovered rods of the hydraulic cylinders.
- Cover the exhaust opening.
- Close and lock all the windows.
- Close and lock the door.



15.3 Restarting the vehicle

Preparing the vehicle after a long period of inactivity:

- Inflate the tires to the correct pressure.
- Remove the jack stands from under the axles.
- Fill the fuel tank.
- Check the radiator coolant level.
- Check the level of the various oils.
- Fit a fully charged battery.
- Remove the cover of the exhaust pipe.
- Remove the layer of grease on the exposed cylinder rods.
- Start the engine and check that all the controls work properly.
- Let the engine run for a few minutes.
- Verify the efficiency of the brake system.

16 ELECTRICAL SYSTEM

16.1 Electrical system wiring diagram

WIRES COLOR	
A	Sky blue
B	White
C	Orange
G	Yellow
H	Gray
L	Blue
M	Brown
N	Black
R	Red
S	Pink
V	Green
Z	Purple
/	Transverse coloring
-	Longitudinal coloring



- NOTE

The coloring of the two-color wires is indicated with the composition of the abbreviations indicated above, using the "/" and "-" symbols.

For example:

G/V = yellow/green transverse coloring

G-V = yellow-green longitudinal coloring



Name	Description	Sheet
A106	Seat Timer	2
A49	Pre-heating control unit	1
A92	Column Switch control unit	2
B1	Battery	1
B10	Front Alignment Seat Microswitch	5
B105	Sitting Man Microswitch	2
B11	Power Steering Lever Microswitch	5
B115	Rear Alignment Seat Microswitch	5
B17	Hydraulic Oil Filter Clogging Pressure Switch	2
B20	Hydraulic Oil Filter Clogging Pressure Switch	2
B210	Pressure switch	5
B23	Diesel Float	4
B28	Fifth Wheel Rotation Pressure Switch	4
B30	Engaged Gear Microswitch	2
B33	2nd Gear Engaged Pressure Switch	2
B38	Water Tool Signal + Water Indicator Light Signal Thermistor	1
B40	Engine Oil Low Pressure Pressure-Switch	1
B41	Water Temperature Switch	2
B42	Thermistor Filter	1
B5	Inclinometer Sensor	4
B6	Horn	2
B7	Stop Pressure Switch	3
B9	Clutch Microswitch	2
B97	Brakes Oil Accumulation Pressure Switch	4
E1	Right Front Headlight	3
E199	Left Lateral Turn Signal	3
E2	Left Front Headlight	3
E200	Right Lateral Turn Signal	3
E22	Right Rear Headlight	3
E24	Right Rear Headlight	3
E3	Overhead Light	4
E95	Rotating light	4
F1A	Fuse +30 Warning	3
F1B	Current Socket and Overhead Light Fuse	4
F2A	High Beam Lights Fuse	2
F2B	Work Lights Fuse	4
F3A	Low Beam Lights Fuse	2
F3B	Warning and Stop Lights Fuse	3
F4A	Engine Stop Fuse	1
F4B	Control Panels Fuse	5

Name	Description	Sheet
F5A	Inclinometer, Column Switch Control Unit and Internal Light Fuse	2
F5B	Ventilation Switch Fuse	4
F6A	Negative Brake Int. Power Supply+Handbrake+Seat Microswitch Fuse	5
F6B	Front and Rear Wiper Switches Fuse	4
F7A	Sidelights Fuse	3
F7B	Rotating Light Fuse	4
F8A	Sidelights Fuse	3
F8B	Horn and Column Switch Fuse	3
FG1	Power Supply Fuse +30	1
FG2	Alternator Fuse	1
FG3	Start Relay Fuse	1
FG4	Optional Filter Pre-heating Relay Fuse	1
G44	Alternator	1
H21	Rear Buzzer	1
K148	Services Relay	1
K149	Horn Relay	2
K37	Thermostarter relay	1
K45	Startup Relay	1
K46	Filter Preheating Relay	1
K85	Machine Off Alarm Relay	1
M113	Window Washer Pump	3
M114	Window Washer Pump	3
M13	Rear Wiper Motor	4
M4	Front Wiper Motor	4
M48	Starter Motor	1
P60	Tool	1
R1	Resistance	2
R36	Filter Pre-heating	1
S0	Battery Disconnecter	1
S145	Rear Wiper Switch	4
S146	Front Wiper Switch	4
S54	N.O. Contact Control panel	5
S54	N.O. Contact Control panel	5
S54	N.O. Contact Control panel	5
S55	N.O. Contact Control panel	5
S55	N.O. Contact Control panel	5
S55	N.O. Contact Control panel	5
S58	Gear Shifter Lever	2
S70	Negative Brake Switch	5
S71	Mix/Discharge Button	5
S75	1st/2nd Manual Gear Switch	5
S76	Starter Panel	1

Name	Description	Sheet
S78	Combination Switch - Turn Signals	3
S80	Rotating Light Switch	4
S81	Pneutron Warning Switch	3
X102	Main Interface - Stud Bolt Connector	
X104	Main Interface - Stud Bolt Connector	
X107	Micro Inching Connector	
X108	Engine Stop Mushroom-head Button Interface Connector 1	
X109	Engine Stop Mushroom-head Button Interface Connector 2	
X110	Engine Stop Mushroom-head Button Interface Connector 3	
X147	Main Interface - Stud Bolt Connector	
X198	Roof Interface Connector	
X25	Rotating Light Extension Connector	
X26	Right Control Panel Interface Connector	
X27	Right Control Panel Interface Connector	
X34	Left Control Panel Interface Connector	
X35	Main Interface - Stud Bolt Connector	
X50	Engine - Stud Bolt Interface Connector	
X51	Engine - Stud Bolt Interface Connector	
X52	Main Interface - Stud Bolt Connector	
X54.1	N.O. Contact Terminal Control panel (Black)	
X54.2	N.O. Contact Terminal Control panel	
X55.1	N.O. Contact Terminal Control panel (Red)	
X55.2	N.O. Contact Terminal Control panel	
X90	Diodes Connector Interface Connector	
X93	Pre-Arrangements Interface Connector	
Y15	Forward Gear Solenoid Valve	2
Y16	Reverse Gear Solenoid Valve	2
Y18	Drum Discharge Solenoid Valve	5
Y19	Drum Mixing Solenoid Valve	5
Y29	Negative Brake Solenoid Valve	5
Y31	1st Manual Gear Solenoid Valve	5
Y32	2nd Manual Gear Solenoid Valve	5
Y39	Engine Stop Solenoid Valve	1
Y56	Hydraulic Fast Solenoid Valve	2

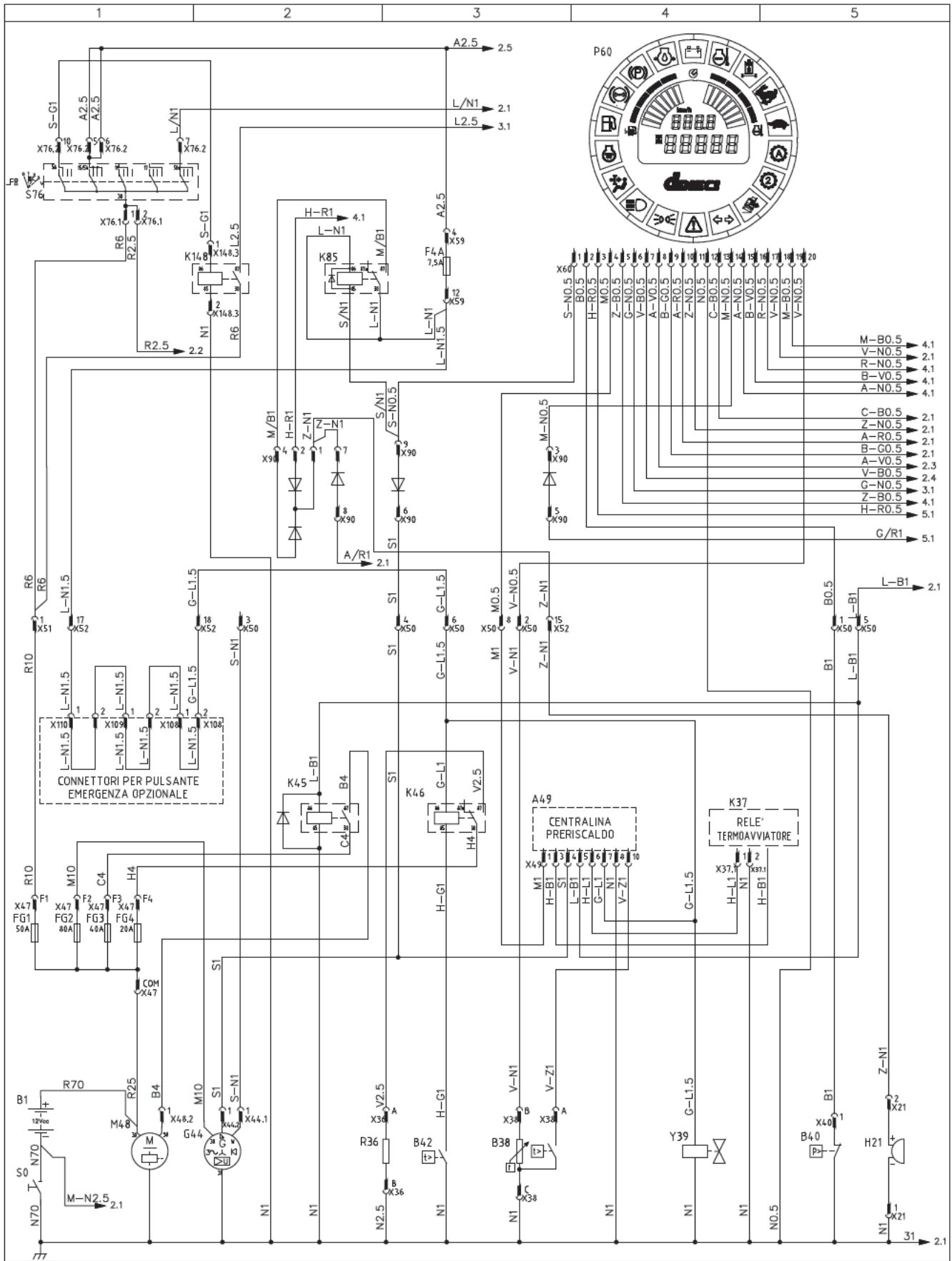

Proprietà della ditta Dieci srl. Senza autorizzazione scritta della stessa il presente disegno non potrà essere comunque utilizzato per la costruzione dell'oggetto rappresentato né venire comunicato a terzi o riprodotto. La ditta proprietaria tutela i propri diritti a rigore di legge. All proprietary rights reserved by Dieci srl. This drawing shall not be reproduced, or in any way utilized, for the manufacture of the component or unit herein illustrated and must not be released to the other parties, without written consent. Any infringement will be legally pursued.

CLIENTE/CUSTOMER DIECI	SOSTITUIZIONE/REPLACED CODE A3	COPIA VALIDA SOLO SE AUTENTICATA Valid certified copy only	NOTE GENERALI/GENERAL NOTES	DESIGNATO/DRAWN LASORSA V.		PAGE 1
DESCRIPTORE/UNIT DESCRIPTION AUTOBETONIERA 2010	MODIFY b	ADDAZ. REV. 00	CONTROLATO/CHECKED MORETTI A.	DATA/DATE 20/01/11		OF 6
CODICE/REF. E25800-057						

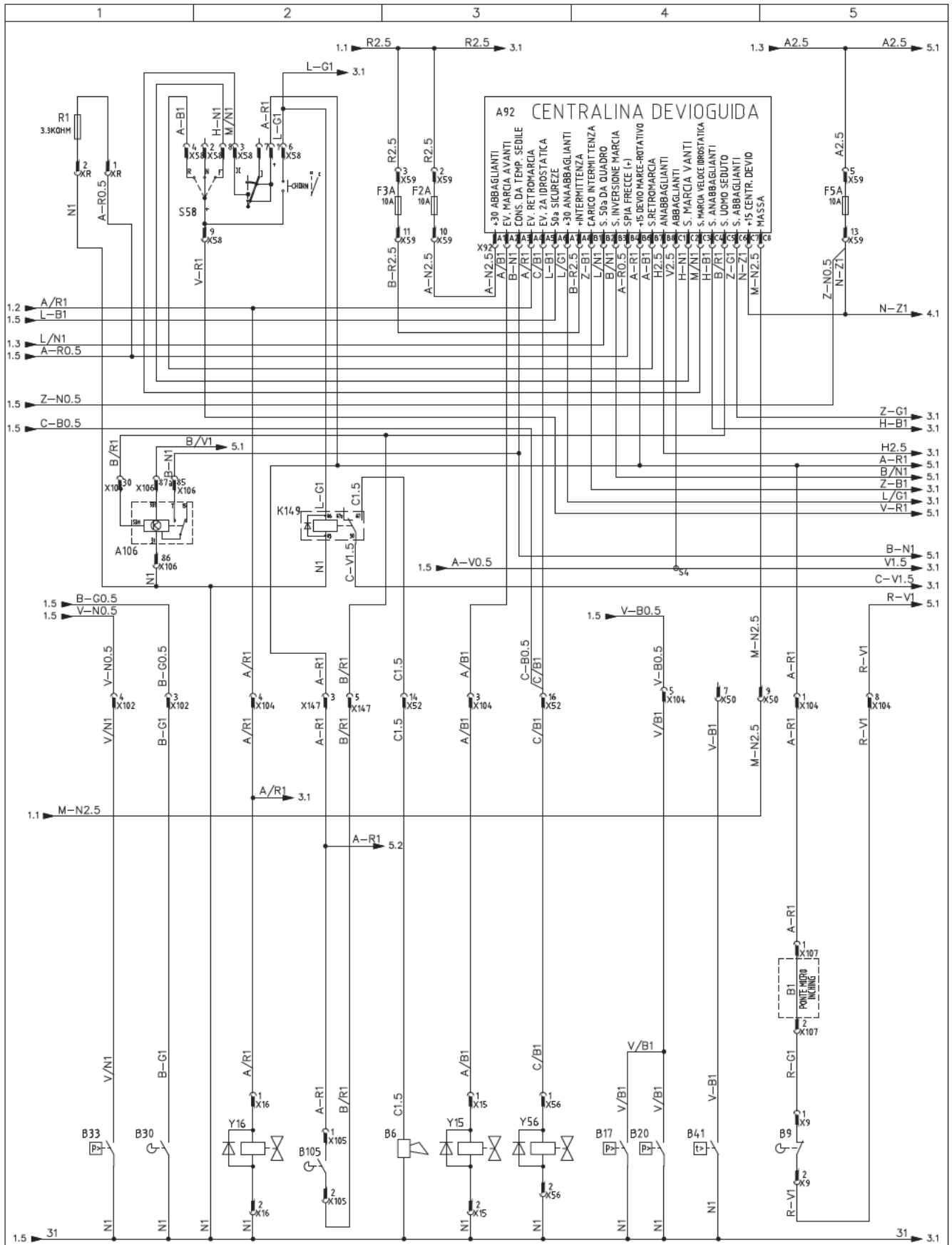

Proprietà della ditta Dieci srl. Senza autorizzazione scritta della stessa il presente disegno non potrà essere comunque utilizzato per la costruzione dell'oggetto rappresentato né venire comunicato a terzi o riprodotto. La ditta proprietaria tutela i propri diritti a rigore di legge. All proprietary rights reserved by Dieci srl. This drawing shall not be reproduced, or in any way utilized, for the manufacture of the component or unit herein illustrated and must not be released to the other parties, without written consent. Any infringement will be legally pursued.

CLIENTE/CUSTOMER DIECI		SOSTITUISCE/REPLACED CODE		NOTE GENERALI/GENERAL NOTES		DESIGNATO/DRWN LASORSA V.			PAGE 2
DENOMINAZIONE/PAINT DESCRIPTION AUTOBETONIERA 2010		FIRMATO/SIE A3		COPIA VALIDA SOLO SE AUTENTICATA Valid certified copy only		CONTROLLATO/CHECKED MORETTI A.			OF 6
CODICE/REF. E25800-057		MODIFY b		ADDAV. REV. 00		DATA/DATE 20/01/11			

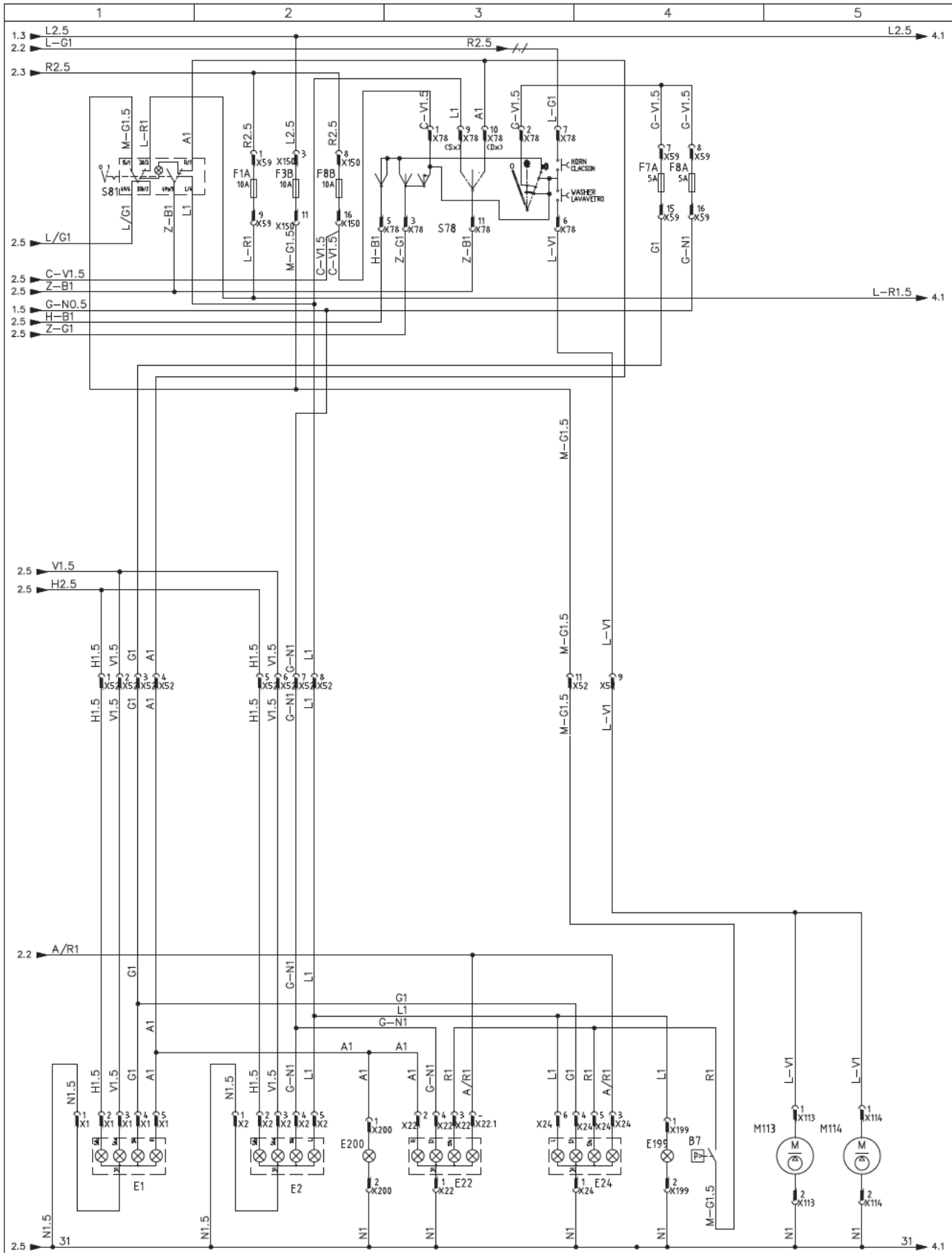

Proprietà della ditta Dieci srl. Senza autorizzazione scritta della stessa il presente disegno non potrà essere comunque utilizzato per la costruzione dell'oggetto rappresentato né venire comunicato a terzi o riprodotto. La ditta proprietaria tutela i propri diritti a rigore di legge. All proprietary rights reserved by Dieci srl. This drawing shall not be reproduced, or in any way utilized, for the manufacture of the component or unit herein illustrated and must not be released to the other parties, without written consent. Any infringement will be legally pursued.

CLIENTE/CUSTOMER DIECI	SOSTITUZIONE/REPLACED CODE	COPIA VALIDA SOLO SE AUTENTICATA Valid certified copy only	NOTE GENERALI/GENERAL NOTES	DESIGNATO/DRIVEN LASORSA V.		PAGE 3
REVISIONE/CHANGE/PART DESCRIPTION AUTOBETONIERA 2010	FINITURA/FIN A3	MODIFY b	ADAX REV. 00	CONTROLLATO/CHECKED MORETTI A.		OF 6
CODICE/REF. E25800-057				DATA/DATE 20/01/11		

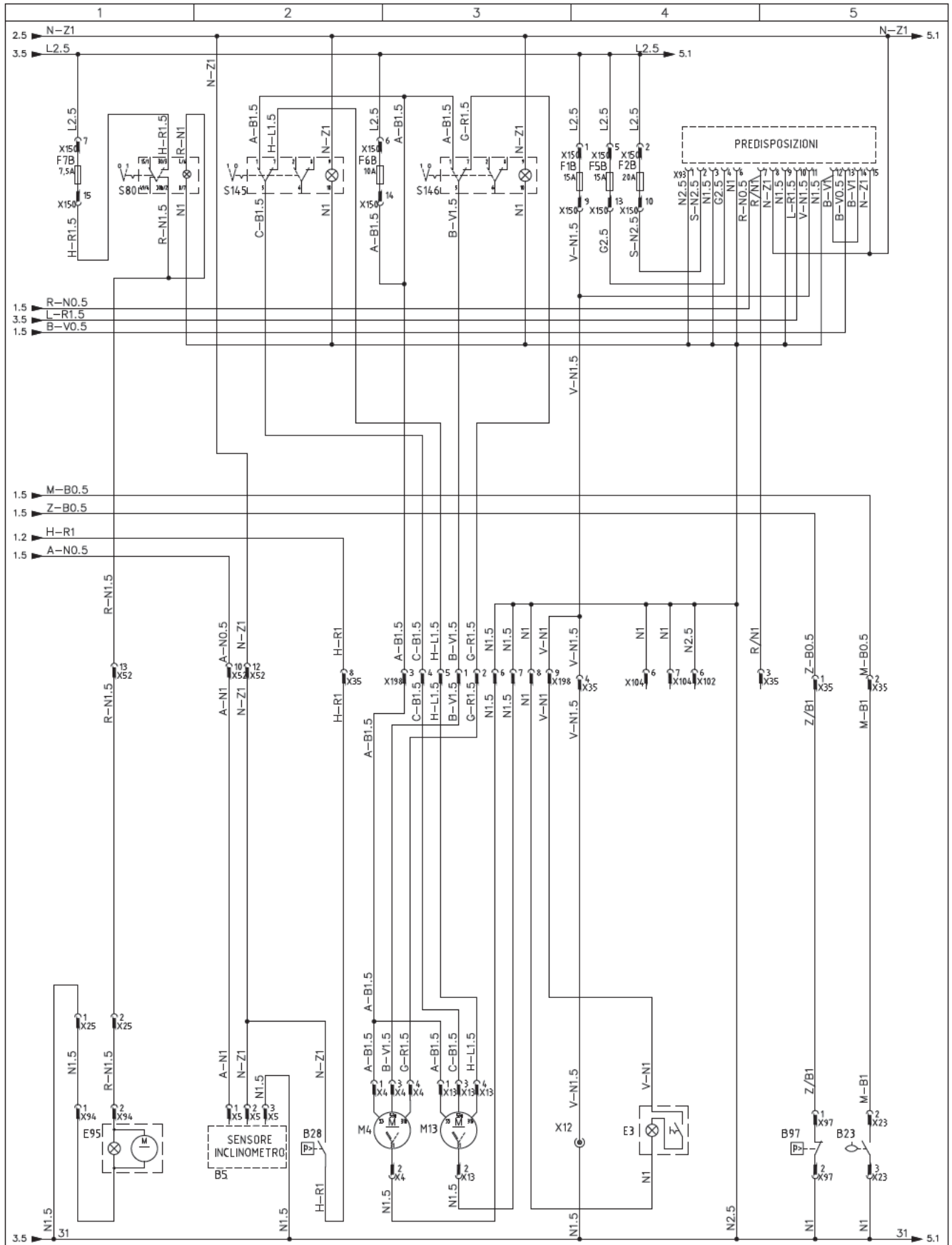

Proprietà della ditta Dieci s.r.l. Senza autorizzazione scritta della stessa il presente disegno non potrà essere comunque utilizzato per la costruzione dell'oggetto rappresentato né venire comunicato a terzi o riprodotto. La ditta proprietaria tutela i propri diritti a rigore di legge. All proprietary rights reserved by Dieci s.r.l. This drawing shall not be reproduced, or in any way utilized, for the manufacture of the component or unit herein illustrated and must not be released to the other parties, without written consent. Any infringement will be legally pursued.

CLIENTE/CUSTOMER DIECI		SOSTITUISCE/REPLACES CODE		NOTE GENERAL/GENERAL NOTES		DESIGNATO/DRAWN LASORSA V.			PAGE 4
DENOMINAZIONE/NAME DESCRIPTION AUTOBETONIERA 2010		FORMATO/SIZE A3		COPIA VALIDA SOLO SE AUTENTICATA Valid certified copy only		CONTROLLATO/CH-EDEDI MORETTI A.			OF
CODICE/REF. E25800-057		MODIFY b		ADDAZ. REV. 00		DATA/DATE 20/01/11			6

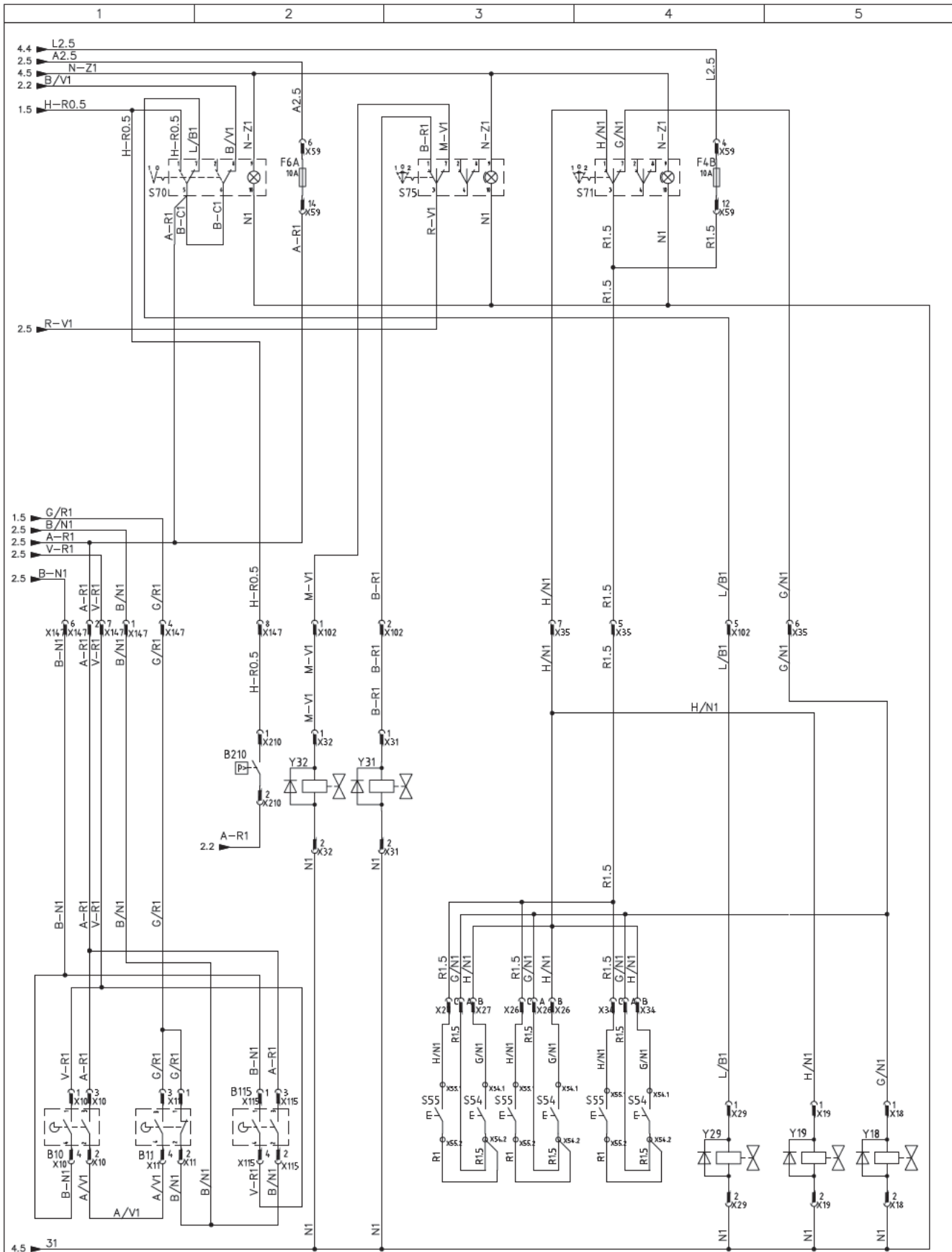

Proprietà della ditta Dieci srl. Senza autorizzazione scritta della stessa il presente disegno non potrà essere comunque utilizzato per la costruzione dell'oggetto rappresentato né venire comunicato a terzi o riprodotto. La ditta proprietaria tutela i propri diritti a rigore di legge. All proprietary rights reserved by Dieci srl. This drawing shall not be reproduced, or in any way utilized, for the manufacture of the component or unit herein illustrated and must not be released to the other parties, without written consent. Any infringement will be legally pursued.

CLIENTE/CUSTOMER DIECI		SOSTITUIRE/REPLACED CODE		NOTE GENERALI/GENERAL NOTES		DESIGNATO/DRAWN LASORSA V.			PAGE 5
DENOMINAZIONE/PART DESCRIPTION AUTOBETONIERA 2010		FORMA/REV A3		COPIA VALIDA SOLO SE AUTENTICATA Valid certified copy only		CONTROLLATO/CHECKED MORETTI A.			OF
CODICE/REF. E25800-057		MODIF. b		ADDAZ. REV. 00		DATA/DATE 20/01/11			6

16.2 Fuses

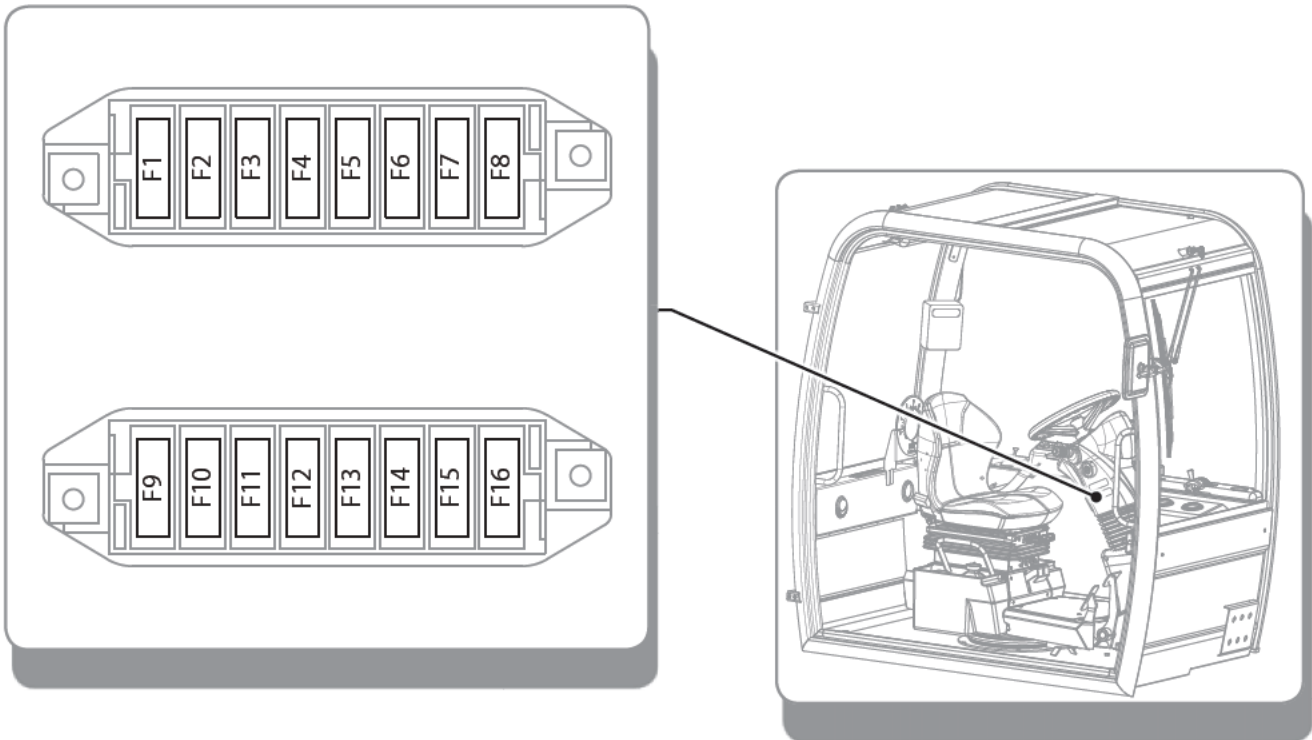

Position	Ampere (A)	Protection
F1	15	Current/overhead light socket
F2	20	Work lights
F3	10	Stop lights
F4	10	Control panel
F5	15	Ventilation switch
F6	10	Wiper switch
F7	7.5	Rotating light
F8	10	Horn / Column Switch
F9	10	Warning
F10	10	High beam
F11	10	Low beam lights
F12	7.5	Engine stop
F13	10	Switches / column switch control unit lighting
F14	10	Brake /seat microswitch switch
F15	5	Side light
F16	5	Side light indicator light



17 HYDRAULIC SYSTEM DIAGRAM

17.1 Hydraulic system L3500

Name	Description
1	Concrete mixer rotation pump
2	Drum rotation motor
3	Valve OLS 80
4	Power steering
5	Deviator
6	Distributor
7	Drum overturning cylinder
8	Valve
9	Throttle
10	Pressure switch
11	Cylinder assembly
12	Drum positioning motor
13	Loading cylinder
14	Motor for water pump
15	Pump
16	Pump
17	Inching Pedal
18	Engine
19	Suction filter
20	Ball valve
21	Negative parking brake solenoid valve
22	Speed change solenoid valve
23	2° gear switch
24	Filter clogging indicator
25	Valve
26	Engine
27	Pressure switch
28	Double brakes pump
29	Throttle
30	Distributor
31	Water-oil radiator

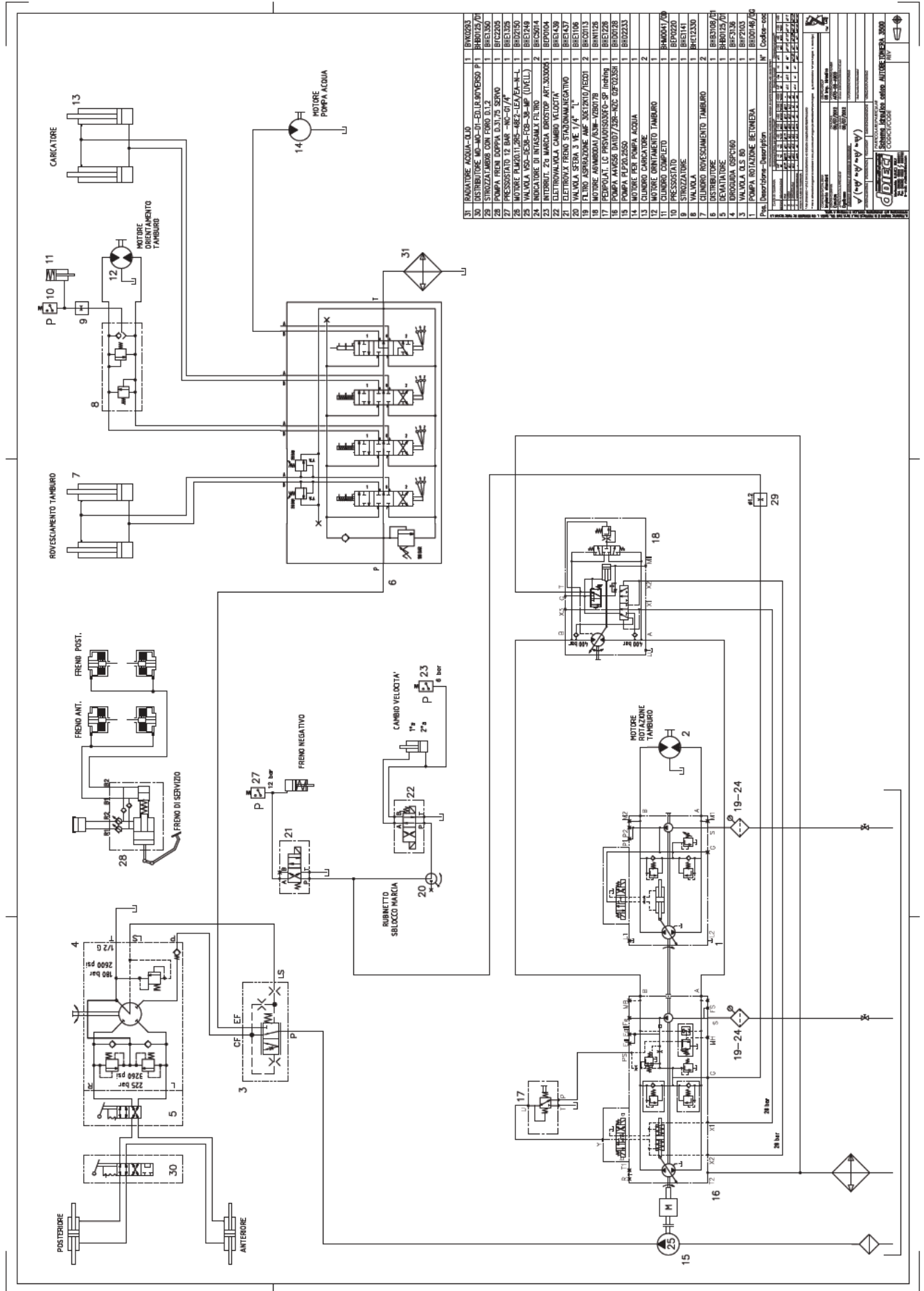

31	RAIATTORE ACQUA-OLIO	1	RW0253
30	DISTRIBUTORE MA-MC-DI-EDILINVERSO P.1.	1	BH0125/61
29	STROZZATORE CON FRENO 0.1.2.	1	BH0130
28	POMPA FRENO DOPIA 0.31.78. SERVO.	1	BFC2205
27	PRESSOSTATO 12 BAR - NC-0/A.	1	BH0126
26	MOTORE RUOTA 1.295-NE2-LEA-4-1.	1	BH0129
25	VALVOLA VSD-303F-3P-3P (DRL).	1	BH0128
24	INDICATORE DI MASSIMA FILTRAZIONE.	2	BH0130/4
23	VALVOLA CAMBIO VELOCITA' ART. 30304.	1	BH0130/5
22	ELETTROVALVOLA CAMBIO VELOCITA'	1	BH0130/6
21	ELETTROVALVOLA FRENO STAZIONAMENTO NEGATIVO.	1	BH0130/7
20	VALVOLA SFERA 3 VE 1/4" 1"	1	BH0106
19	FILTRO ASPIRAZIONE AMP 30E17K10/EC01.	2	BH0113
18	MOTORE AMBRODAI/ANM-V2007/9.	1	BH01126
17	PEDIPOL. LC PSHV01500FO-SP. Inching.	1	BH01226
16	POMPA AVOSB DAD07/238-402. DP02351.	1	BH01238
15	POMPA PUP202550.	1	BH02233
14	MOTORE CARICATORE ACQUA.	2	
13	CARICATORE ACQUA.	2	
12	MOTORE ORIENTAMENTO TAMBURO.	1	BH0017/9
11	CILINDRO COMPLETO.	1	BH02220
10	PRESSOSTATO.	1	BH01141
9	STROZZATORE.	1	BH01230
8	DISTRIBUTORE.	2	BH01250/2
7	CILINDRO ROVESCIAMENTO TAMBURO.	1	BH01250/1
6	CILINDRO ROVESCIAMENTO TAMBURO.	1	BH01250/2
5	CILINDRO CAMBIO MARCIA.	1	BH01250/3
4	CILINDRO CAMBIO MARCIA.	1	BH01250/4
3	VALVOLA OLS 80.	1	BH02103
2	POMPA ROTAZIONE BENTONERA.	1	BH01046/2
1	FRENO ANTERIORE.	1	BH01046/1
1	FRENO POSTERIORE.	1	BH01046/3



17.2 Hydraulic system L4700

Name	Description
1	Concrete mixer rotation pump
2	Drum rotation motor
3	Valve OLS 80
4	Power steering
5	Deviator
6	Distributor
7	Drum overturning cylinder
8	Valve
9	Throttle
10	Pressure switch
11	Cylinder assembly
12	Drum positioning motor
13	Loading cylinder
14	Motor for water pump
15	Pump
16	Pump
17	Inching Pedal
18	Engine
19	Suction filter
20	Ball valve
21	Negative parking brake solenoid valve
22	Speed change solenoid valve
23	2° gear switch
24	Filter clogging indicator
25	Valve
26	Engine
27	Pressure switch
28	Double brakes pump
29	Throttle
30	Distributor
31	Water-oil radiator

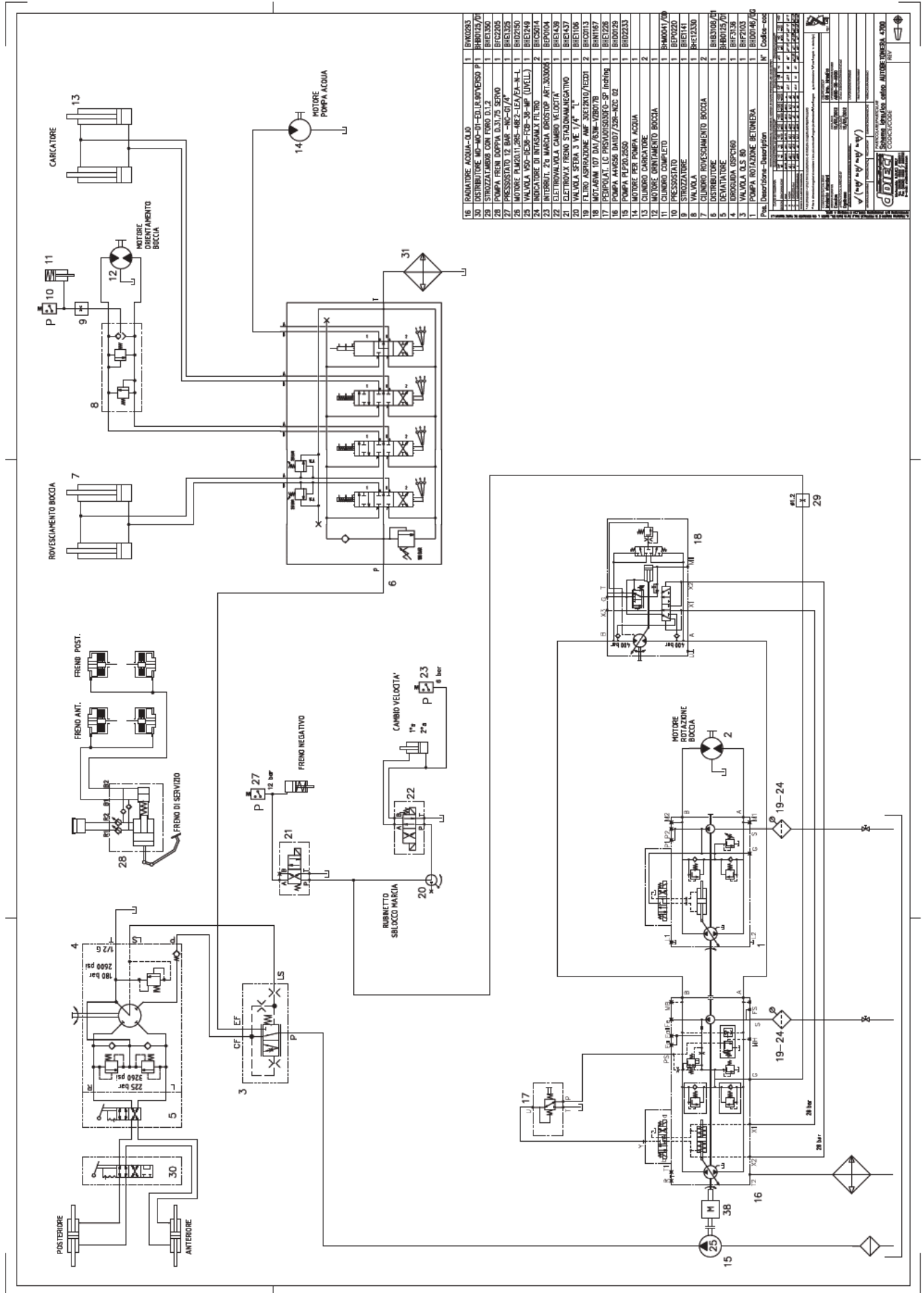

18 CONTROL AND MAINTENANCE LOGS

The Control Log and Maintenance Log are to be considered as integral parts of the machine and equipment. These logs must therefore accompany the machine and equipment for their life, to final disposal.

18.1 Type of logs

18.1.1 Control log

On the Control Log are recorded the main checks on the **safety devices** of the equipment, recommended by **DIECI S.R.L.**, with the related deadlines.

These checks ensure the proper operation of the safety devices.



- CAUTION

The checks specified in the Control Log are in addition to the routine maintenance described in the Equipment Maintenance Log.

18.1.2 Maintenance Log

On the Maintenance Log are recorded all scheduled maintenance with timelines, referred to the use in normal, and not heavy, conditions.

The scheduled maintenance intervals frequency must be reduced even to daily, if necessary, in particularly heavy working conditions (humidity, mud, sand, high dust level, etc ...).



Consult the DIECI service center to establish appropriate timelines when working in particularly heavy environments.

Such maintenance interventions allow to keep the machine or the equipment in the best efficiency conditions.

18.2 Instructions for compiling the logs

18.2.1 Warnings on the control log

- The log must be prepared in accordance with the requirements imposed by the Essential Safety Requirement 4.4.2.b Annex I of the Machinery Directive 2006/42/EC, in order to preserve evidence of the proper conduct of all the inspection and maintenance activities concerning the machine safety.
- In the log, in addition to all the activities relating to the life, use and maintenance of safety systems of the machine (replacement of parts, overhauls, breakdowns, etc.) it is necessary to record all the checks required by the regulations in force in the country where the machine is used.
- It is also necessary that the name of the verifier technician and date of intervention are clearly identifiable.
- It is recommended to prepare, update and preserved with care, for the entire life of the machine or equipment, the control log.



- NOTE

At the end of the manual there are some pages to allow compiling such logs.

18.2.2 Warnings on the maintenance log







- The maintenance log shall prevail for warranty claims. All activities relating to the life, use and maintenance of the machine must be registered in the log.

18.2.3 Logs compiling

Each log (Fig. 1-L0000) requires the compilation of several parts:

1. Log data
2. Operations to carry out
3. Component or device on which to carry out the operation to be performed
4. Space that indicates the obligatory operation marked by the symbol "o", and the possibility to annotate an extraordinary operation not included in the log.

18.2.4 Logs legend

Symbol	Description
	Control - Check
	Refueling
	Adjustment
	Cleaning
	Replacement
	Lubrication
	Intervention at an authorized service center

Timelines	Description
0h	According to the need - To be completed in the case of checks not linked to deadlines but more or less related to the heavy operation of the machine
10h / 1m	Every 10 hours or every month
50h / 1m	Every 50 hours or every month
250h / 2m	Every 250 hours or every 2 months
500h / 6m	Every 500 hours or every 6 months
1000h / 1y	Every 1000 hours or every year
2000h	Every 2000 hours
4000h	Every 4000 hours
2y	Every 2 years

18.3 Periodic checks and recording mode (Italian only)

- The employer/operator of the machine is required to submit the machine to the periodic checks provided by law (Ministerial Decree 12/9/59 and Legislative Decree 81/08).
- He/she also has the obligation to comply with the maintenance and surveillance plan described in this Use and Maintenance Manual of the machine.
- The periodic inspection, testing and maintenance must be carried out by specialized personnel appointed for that purpose or by a workshop authorized by the manufacturer DIECI S.r.l.
- The employer/operator of the machine must record or appoint personnel trained for the purpose to record the results of the checks into the Control Log.
- Regular checks that have to be entered in the "Control log" are:
 - Quarterly periodic checks regarding the functionality and/or efficiency of ropes/chains according to Annex VI section 3.1.2 of Legislative Decree 81/08;
 - Yearly periodic checks regarding the operation and storage of the machine for safety purposes (yearly inspections, corrosion control, calibration check, etc.) in accordance with Annex of Legislative Decree 81/08;
- The law provides administrative sanctions against those who do not carry out the quarterly and yearly checks.
- The Control Log, in which it is necessary to record the checks, must be shown on request to the officials responsible for monitoring the current legislation.
- Following the yearly periodic check the Local Health Authority official (Dip.SSIA), or the private Enabled Party chosen, issues a suitability report or prescribes the necessary obligations. The user is obliged to preserve the check report together with the Control Log.
- The checks evaluation must be recorded in the following dedicated pages indicating the outcome of the check, date, signature and any comments of the party in charge.
- If the pages dedicated in this Manual are insufficient for the annotations made in the life of the machine, use additional sheets being careful to compile them in the same way.



18.4 Obligation and how to report to I.N.A.I.L. (National institute for insurance against accidents at work) (Italy only)

- The Ministerial Decree of 12/09/1959, Title II - Article 7 prescribes the obligation, to employers and users of lifting equipment with motor with capacity > 200 kg and lifting platforms for persons, to report the successful commissioning to the competent authority of the territory of the machine (currently I.N.A.I.L.), specifying the place of installation of the machine so that the authority itself may carry out the first verification.
- The report to I.N.A.I.L. must be carried out by attaching to the machine commissioning report a copy of the EC Declaration of Conformity of machinery referred to in Annex IIA of the Legislative Decree 17/2010 - Machinery Directive 2006/42/ EC.
- The original statements (CE Declaration of Conformity - Annex IIA) must be retained by the customer.
- The report to I.N.A.I.L. may be sent by registered letter with return receipt.

ALPHABETICAL INDEX

A

Accelerator	70
Acoustic signal	66
Additional guarantee for repairs and replacement parts	9
Addressees	1
Air Conditioning (A/C) *	81
Air conditioning system: Checking and cleaning	130
Air filter: Cleaning and replacement	139
Anti-accidental operation devices	62
Assistance provided to the owner/ operator	148
Avoid accidents during maintenance	123

B

Back	41
Battery	89
Battery cut-off switch	92
Battery: Recharging the battery	91
Battery: Replacement	92
Belts: Check and adjustment	130
Bolts tightening torque	145
Bolts tightening torque: Adjustment	130
Brake	70
Brake: Inspection	134
Brakes	150
Brakes oil: Check and replacement	134

C

Cab	43
Cab ventilation filter: Cleaning and replacement	131
Causes of failed start-ups	109
Central instrument panel	46
Central instrument panel	65
Certification and CE marking	34
Checking for damage	23
Cleaning	151
Cleaning and storing fuel	86
Cleaning of the safety stickers	153
Cleaning the cab	152
Cleaning the vehicle	151
Coarse pitch	146
Components description and use	64
Connecting the cables and starting the engine	117
Contact with dangerous substances	21
Contraindications for use	33
Control and maintenance logs	172
Control log	172

D

Deactivate transmission manually	121
Deactivating the external parking brake manually	120
Declaration of first test	33
Description of components	82
Differential axle maintenance	144
Differential axle oil: Inspection and change	144
Dimensions	47
Direction indicators	68
Door *	80
Door glass opening/closing	80
Driver's seat restoring	114



Driver's seat reversal	113
Driver's seat reversal pedal	72
Drive shafts: Lubrication	128
Driving downhill with a full load	110
Driving downhill without a load	110
Driving uphill with a full load	110
Driving uphill without a load	110
Dual reflector working light *	96
Dump body lifting control lever	79
Dumper symbols legend	7

E

Electrical system	159
Electrical system protection	25
Electrical system wiring diagram	159
Emergency call	16
Emergency lights switch	73
Emergency procedures	115
Emergency stop switch	61
Engine	88
Engine	149
Engine hood	42
Engine hood opening	127
Engine oil: Check and filling up	136
Engine oil filter: Replacement	132
Engine oil temperature indicator	65
Ensuring the vehicle is clean	23
Epicycloidal reduction gear oil: Inspection and change	142
Examining replaced faulty parts	9
Exclusions from the guarantee	8

F

Fastening the seat belt	103
Final terms	11
Fine pitch	145
First Aider Tasks	16
Front	41
Front light	93
Front window wiper	73
Fuel	85
Fuel filter: Replacement	132
Fuel level indicator	65
Fuel tank: Cleaning	87
Fuses	167

G

Gear selection lever	61
Gear selection lever	67
General	31
General information	31
General warnings	12
General warnings	36
General warnings	97
General warnings for truck mixers	99
General warnings for use	64
General warnings regarding starting up the machine	106
Glass on engine side *	81
Going up or down from the cab	101
Guarantee	8
Guarantee: activation	9
Guarantee: claim	10
Guarantee: duration	8
Guarantee in countries with assistance centres	9
Guarantee in countries with NO assistance centres	9

Guarantee: intervention request	10
Guarantee: termination	10
Guarantee: validity	8
Guarantee: validity	9

H

Haemorrhages	17
Hand throttle control lever	78
Heating *	81
Horn	68
Hourmeter	65
Hydraulic fittings tightening torque: Adjustment	131
Hydraulic fittings tightening torques	147
Hydraulic oil: Check and replacement	135
Hydraulic oil filter: Replacement	132
Hydraulic oil intake filter: Replacement	133
Hydraulic system diagram	168
Hydraulic system L3500	168
Hydraulic system L4700	170
Hydraulic transmission system	149

I

Identification of the machine	32
Inching	70
Initial check	66
Inspecting the machine	104
Inspecting the work area	105
Inspections prior to starting-up	104
Instructions for compiling the logs	172
Instrument panel	45
Intended use	33
Intervention campaigns for faulty products	9

Introduction	1
--------------------	---

L

LCD display	46
Left instrument panel	44
Left side	39
Liability	33
Lifting, transport and storage	154
Lighting	93
Lights: Inspection	134
Logs compiling	173
Logs legend	174
Long period of inactivity	157
Long period of inactivity	157
Low maintenance batteries	90

M

Machine description	38
Machine lifting	154
Machine towing	118
Machine towing with engine running	119
Main components position	39
Main leaf opening/closing	80
Maintenance	122
Maintenance Log	172
Maintenance operations	127
Maintenance warnings	122
Manual structure	1
Manufacturer	34
Meaning of safety stickers	54
Mechanical joints: Lubrication	128
Momentary stop	112



Moving on sloped ground	110
Moving safely	110
Multifunction lever	68

N

non-acknowledgement	10
Non-activation, failure to honour, termination	10
Notes	184

O

Obligation and how to report to I.N.A.I.L. (National institute for insurance against accidents at work) (Italy only)	176
Obligation of vehicle downtime	10
Oil change: Inspection	141
Oil change: Inspection and change	141
Operator's seat adjustment	102

P

Parking brake switch	61
Parking brake switch	75
Parking the vehicle	112
Passengers transportation	24
Pedals	70
Periodic checks and recording mode (Italian only)	175
Personal protective devices	14
Power steering reversal lever	72
Preliminary maintenance operations	126
Prepare the vehicle for maintenance	126
Preparing for accidents	16
Preservation	1
Pressure gauge *	71

Preventing fires and accidents	18
Problems diagnostics	149
Protections against the falling of objects from a height	15
Protective clothing	14
Protect yourself against noise	15
Protect yourself from flying fragments	15
Purpose and content	1

Q

Qualification	3
---------------------	---

R

Radiator: Check, cleaning and filling up	137
Rear light	95
Rear window wiper	73
Refueling	87
Removing the cables	117
Residue risks	20
Restarting the vehicle	158
Revolving driver's seat	43
Right side	40
Rim size, tires and inflation pressure table	84
Risks of batteries exploding	19
Risks of fires	18
Risks of inhaling gas	19
Road travel	111
Road travel instructions	111
Road travel warnings	111
ROPS - FOPS Cab	63
Rotating light switch	73

S

Safety devices	53
Safety indications	13
Safety regulations.....	12
Safety stickers	53
Safety stickers: Inspection	131
Safety stickers position in the cab.....	60
Safety stickers position on the machine	57
Safe work procedures	97
Seat.....	62
Service Centers	34
Signals to multiple vehicles	26
Slow/fast gear shift button.....	74
Spare parts supply	148
Specifications for recommended fuel.....	85
Starting and stopping the machine.....	106
Starting-up the engine	107
Start-up at low environmental temperatures.....	109
Start-up using auxiliary batteries.....	116
Start working with the vehicle.....	23
Steering mode control lever	76
Steering wheel.....	150
Storing dangerous liquids.....	22
Storing the vehicle	157
Switching on the headlights.....	69
Switching on the high beam lights	69
Symbols key in manual.....	6

T

Tachometer	65
Technical data.....	47
Technical service centre.....	148
Terms, units of measurement and abbreviations used	4

Tightening the wheel nuts.....	83
Tightness of the wheel nuts: Inspection.....	143
Towing the machine with engine in failure.....	119
Training.....	2
Training.....	2
Transmission maintenance	141
Transporting the vehicle.....	155
Transporting the vehicle on a trailer	155
Traumas	17
Turn off the machine	109
Type of logs.....	172
Tyre pressure: Inspection.....	143
Tyres.....	82

U

Urethane foam filled tyres	83
Used symbols.....	6

V

W

Warm-up after starting-up	108
Warnings for safe working	23
Warnings if the vehicle should overturn.....	115
Warnings on the control log	172
Warnings on the maintenance log	173
Washing the windows.....	151
Wheel maintenance	142
Wheels alignment	77
Window washer *	68
Window washer tank: Filling up.....	138



Working in closed areas or dangerous atmospheres	30
Working light *	96
Working under the snow.....	29
Working with scarce lighting.....	29
Working with the danger of masses and objects falling	28
Work near electrical lines.....	28

Z

"Zero maintenance" batteries.....	90
-----------------------------------	----



