

**HERCULES** 100.10 - 120.10  
MAINTENANCE MANUAL

 1300 888 479

 [sales@dieciaustralia.com.au](mailto:sales@dieciaustralia.com.au)

 1/5 Melito Court, Prestons NSW

 [www.dieciaustralia.com.au](http://www.dieciaustralia.com.au)



**USE AND MAINTENANCE MANUAL**

Issued by	Document code	Issue date	Review date	Prepared by
Technical Documentation	DOCMA0000071 – Rev. 2.2	02/2019	06/2021	Technical Documentation

## Original instructions for:

	Vehicle model	Brand	Emission standard	Nominal power	Homologation	Area	Sector
MFR3202	HERCULES 100.10	FPT	Stage IIIA/Tier 3	104 kW (139 HP)	XLC203	WORLD	CONSTRUCTION
MFS3203	HERCULES 120.10	FPT	Stage IIIA/Tier 3	104 kW (139 HP)	XLC203	WORLD	CONSTRUCTION

## Standards

This manual is prepared in Italian in accordance with the provisions indicated in the following Standards:

- EN1459-1
- ISO 3600:2015
- ISO 6750:2005
- M.D. 2006/42/EC

Dear Customer,

congratulations and thank you for choosing **DIECI**.

This Use and Maintenance Manual has been written to help you fully appreciate the quality of products by **DIECI**.

We strongly recommend that you read this manual in its entirety before using the vehicle.

It contains information, advice and important warnings that will help you to fully take advantage of the technical capabilities of your products by **DIECI**.

You will learn about its features and special practical information in addition to information about its maintenance, driver and operation safety to help maintain over time your products by **DIECI**.

We are confident that you will be happy with your new purchase and we remain at your disposal should you have any further queries.

Sincerely,

**Sales Management**



[www.dieci.com](http://www.dieci.com)

**Dieci s.r.l.**

VIA E. MAJORANA, 2-4

42027 - MONTECCHIO E. (RE) - ITALY

TEL. ++39 0522-869611

FAX ++39 0522-869744

e-mail: [info@dieci.com](mailto:info@dieci.com)

Fully paid-up share capital € 10.000.000,00

Companies Register C.R. No. 01283560686 - Economic and Administrative Index C.R. No. 204278

Tax Code 01283560686 - VAT no. 01682740350



## 1.1 - General information

Each vehicle is provided with:

- Copy of this manual
- A copy of the use and maintenance manual of the engine prepared by the manufacturer
- A copy of the use and maintenance manual for each device or equipment which is installed on this vehicle.

These manuals have been prepared by the respective suppliers and are faithfully reproduced in full by *DIECI S.R.L.* Behind their specific authorization: they can be enriched with additional specifications drawn up by *DIECI S.R.L.*



### WARNING

All documentation provided is an integral and essential part of the product and must be kept at the disposal of the users; they must carefully read what is written in the above mentioned documentation before using it.



### DANGER

Improper, incorrect or unreasonable use of the vehicle or accessory installed on it is not allowed as also any intervention that alters its structure or function is not allowed.



### NOTE

**Reproduction of all or part of the contents of this manual and any multimedia attachment.**

*Dieci s.r.l.* will protect the ownership rights of these materials.



### ATTENTION

A copy of this manual must always be available to the operator on the vehicle.

This vehicle has been designed and built as a self-propelled vehicle with operator's seat, wheels, designed for use on paved or natural ground and on uneven ground.

It consists of a main support structure suitable to support the extensible boom.

The head of the boom can be fitted with forks or other equipment only if approved by *Dieci s.r.l.* or only if the manufacturer of the equipment declares that its use conforms with the type of machine.

When used normally, the machine performs loads lifting and positioning by extending/ retracting, lifting/lowering the boom.



### WARNING

**Any other use is considered contrary to the intended use by *DIECI s.r.l.* which, therefore, can not be responsible for damage to objects and the machine itself, or injury to persons that might derive from misuse.**

For other controls, or complaints to agencies, refer to the applicable local legislation in the country of use of the vehicle.

## 1.2 - Identification of the vehicle

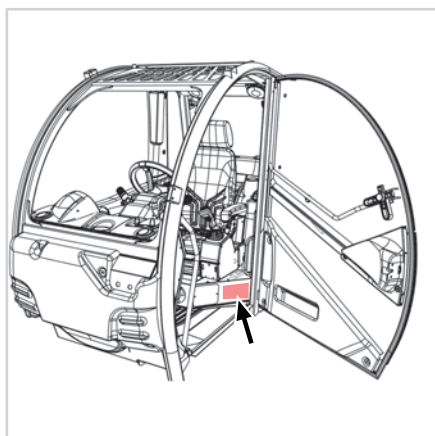

150640-1

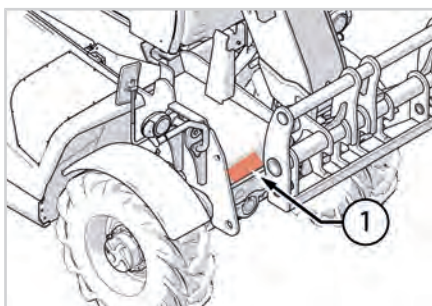

150640-2

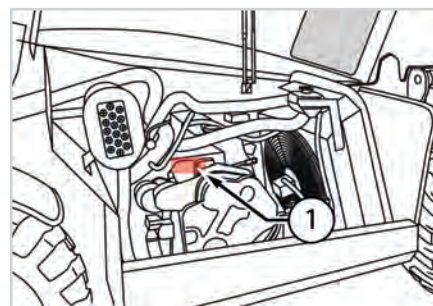

150640-3

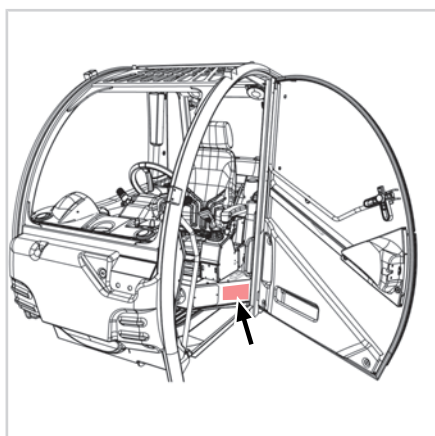

150640-4

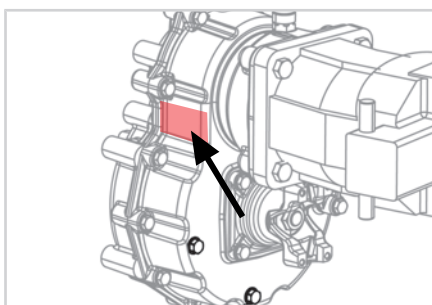

150640-5

Vehicle model (fig. 150640-1)	.....
Year	.....
Serial number of the chassis (fig. 150640-2)	.....
Serial number of the engine (fig. 150640-3)	.....
Serial number of the cab (fig. 150640-4)	.....
Serial number of the transmission gearbox (fig. 150640-5)	.....
Owner / Operator	.....
Address of the Dealer or Agent	.....

Delivery date	.....
Warranty expiry date	.....

Equipment code	Serial number	Year
.....	.....	.....
.....	.....	.....
.....	.....	.....
.....	.....	.....

# Contents

<b>1</b>	<b>Info .....</b>	<b>3</b>
1.1	General information.....	5
1.2	Identification of the vehicle .....	6
	<b>Definitions .....</b>	<b>17</b>
<b>2</b>	<b>Introduction .....</b>	<b>18</b>
2.1	Manual structure .....	18
2.2	Purpose and content .....	18
2.3	Preservation .....	18
2.4	Recipients .....	18
2.4.1	Training.....	18
2.4.2	Training.....	19
2.4.3	Qualification.....	19
2.5	Classification of dangers.....	19
2.6	Machine general warnings .....	20
2.7	Equipment general warnings .....	21
2.8	Intended use.....	21
2.9	Contraindications for use.....	21
2.10	Declaration of first test.....	21
2.11	Liability.....	21
2.12	Manufacturer .....	22
2.13	Vehicle identification label .....	22
2.14	Certification and CE marking .....	23
2.15	Units of measurement and abbreviations used.....	24
<b>3</b>	<b>Warranty .....</b>	<b>26</b>
3.1	Exclusions from the warranty .....	26
3.2	Delivery and installation.....	26
3.3	Warranty: duration .....	26
3.4	Warranty: commencement.....	26
3.5	Warranty: activation.....	26
3.6	Warranty procedure.....	27
3.7	Intervention campaigns for faulty products .....	27
3.8	Warranty: intervention request.....	27
3.8.1	Guarantee: claim .....	27
3.8.2	Obligation of vehicle downtime.....	27
3.9	Non-activation, failure to grant, termination.....	27
3.9.1	Warranty: failure to grant.....	27
3.9.2	Guarantee: termination .....	27
3.10	Final terms .....	28
<b>4</b>	<b>Safety regulations.....</b>	<b>29</b>
4.1	General warnings .....	29
4.2	Safety indications.....	30
4.3	Personal protective equipment.....	31

4.3.1	Protective clothing .....	31
4.3.2	Protect yourself against noise .....	31
4.3.3	Protections against objects falling from height.....	32
4.3.4	Protect yourself from flying fragments .....	32
4.4	Preparing for accidents.....	32
4.4.1	First Aider Tasks .....	32
4.4.2	Emergency call .....	32
4.4.3	Traumas .....	33
4.4.4	Hemorrhages .....	33
4.5	Preventing fires and accidents .....	33
4.5.1	Risks of fires .....	33
4.5.2	Risks of inhaling gas .....	34
4.5.3	Risks of batteries exploding .....	34
4.5.4	Residual risks.....	34
4.5.5	Contact with dangerous substances .....	35
4.6	Storing dangerous liquids .....	35
4.7	Warnings for safe working.....	37
4.7.1	Ensuring the vehicle is clean.....	37
4.7.2	Checking for damage .....	37
4.7.3	Start working with the vehicle .....	37
4.7.4	Passengers transportation.....	37
4.7.5	Electrical system protection.....	37
4.7.6	Signals to multiple vehicles.....	39
4.7.7	Working with the danger of falling masses and objects .....	41
4.7.8	Working near electrical lines.....	41
4.7.9	Working under the snow.....	41
4.7.10	Working with scarce lighting.....	42
4.7.11	Working in closed areas or dangerous atmospheres.....	42
4.7.12	Reduce vibrations .....	43
4.8	Working in windy conditions.....	43
4.9	Assessing the consistency of the work ground.....	44
4.10	Moving safely .....	44
4.11	General warnings for moving the load .....	45
4.12	Use of cables, ropes and slings .....	46
4.13	Road travel.....	46
4.13.1	Road travel warnings .....	46
4.13.2	Road travel instructions .....	47
4.14	Momentary stop.....	47
4.15	Parking the vehicle .....	48
4.16	Starting and stopping the vehicle .....	48
4.16.1	General warnings regarding starting up the vehicle .....	48
4.16.2	Inspections prior to starting-up.....	48
4.16.3	Starting-up the engine.....	49
4.16.4	Warm-up after starting-up.....	50
4.16.5	Start-up at low environmental temperatures.....	50
4.16.6	Causes of failed start-ups .....	50
4.16.7	Turn off the vehicle.....	50
<b>5</b>	<b>Vehicle description .....</b>	<b>51</b>
5.1	Left side components description .....	52
5.2	Right side components description .....	53
5.3	Engine components description .....	54
5.4	Cab components description .....	55

<b>6</b>	<b>Safety devices .....</b>	<b>56</b>
6.1	List of safety devices .....	56
6.2	Safety stickers.....	57
6.2.1	Warnings for safety stickers.....	57
6.2.2	Meaning of safety stickers .....	58
6.2.3	Safety stickers position on the vehicle .....	62
6.2.4	Safety stickers position in the cab.....	63
<b>7</b>	<b>Components description .....</b>	<b>64</b>
7.1	Cab .....	64
7.1.1	ROPS - FOPS Cab .....	64
7.1.2	Door opening .....	65
7.1.3	Climbing in/out.....	65
7.1.4	Door glass .....	66
7.1.5	Heated mirrors * .....	66
7.1.6	Rear glass .....	67
7.1.7	Canopy.....	67
7.1.8	Sunshade.....	67
7.1.9	Cab ventilation.....	68
7.1.10	Air conditioning * .....	69
7.1.11	Cab lighting.....	69
7.1.12	12V Socket .....	70
7.1.13	Storage compartment.....	70
7.1.14	Steering wheel .....	70
7.1.15	Multifunction lever .....	70
7.1.16	Lights turning on.....	72
7.1.17	Emergency Lights .....	74
7.1.18	Seat.....	74
7.1.19	Emergency stop.....	77
7.1.20	Spirit Level .....	77
7.1.21	Emergency exit: Rear glass .....	78
7.1.22	Cab front glass protection * .....	78
7.1.23	Warnings in case of vehicle tipping .....	78
7.2	Parking brake.....	79
7.2.1	Pressure gauge .....	79
7.2.2	Braking circuit errors list .....	80
7.2.3	Deactivating the internal parking brake manually .....	80
7.3	TFT Instrument panel .....	81
7.3.1	Components .....	81
7.3.2	Initial check .....	83
7.3.3	Home .....	83
7.3.4	Clock and clock setting .....	84
7.3.5	Hour meter .....	84
7.3.6	Levelness Icon .....	85
7.3.7	Steering mode icon.....	85
7.3.8	Function Icon for special equipment.....	85
7.3.9	Change Direction Alarm Icon .....	86
7.3.10	Menu.....	87
7.3.11	Active errors.....	88
7.3.12	Service .....	89
7.3.13	Limits .....	90
7.3.14	Anti-tipping device.....	91
7.4	Electrical steering selector.....	98
7.5	Automatic wheels alignment * .....	99
7.6	Joystick.....	100
7.6.1	Joystick with capacitive deadman sensor .....	100

7.6.2	Joystick for man basket prearrangement .....	101
7.6.3	Joystick error list.....	102
7.7	Hydraulic sockets and electrical contact on boom head * .....	103
7.8	Electrical contact on boom head * .....	104
7.9	Equipment quick coupling * .....	105
7.9.1	Quick coupling with single lock on open circuit vehicle.....	105
7.10	Safety rod.....	105
7.11	Wheel wedge.....	106
7.12	Block valves.....	106
7.13	Diagrams notebook .....	106
7.13.1	Load Charts .....	106
7.14	Water heater * .....	110
7.15	Transmission.....	110
7.15.1	Movement selection lever * .....	110
7.15.2	Manual gear shift selection .....	112
7.15.3	Service braking pedal .....	112
7.15.4	Inching Pedal .....	113
7.15.5	Accelerator pedal.....	113
7.15.6	Manually disable off the 2-gear hydrostatic transmission.....	114
7.16	Remote Control * .....	115
7.16.1	Remote Control: Description .....	115
7.16.2	Remote Control: Use .....	119
7.16.3	Remote Control: Turn off the vehicle and the remote control.....	120
7.16.4	Remote Control: Receiver .....	120
7.16.5	Remote Control: Recharge.....	120
7.16.6	Remote Control: Back-up .....	120
7.16.7	Remote Control: Additional information.....	120
7.17	Electronic hand throttle.....	120
7.18	Automatic differential lock * .....	121
7.19	Automatic axle swing lock.....	121
7.20	Automatic fan reversal .....	122
7.21	Transverse levelling device * .....	122
7.22	Boom down control valve * .....	123
7.23	FPT Series NEF4, Stage IIIA /Tier 3 .....	123
<b>8</b>	<b>Equipment.....</b>	<b>124</b>
<b>9</b>	<b>Equipment.....</b>	<b>000</b>
9.1	General warnings on equipment use .....	126
9.1.1	Equipment pre-use checks .....	127
9.1.2	Bucket warnings .....	128
9.2	Equipment installation procedure.....	129
9.3	Hydraulic connections .....	131
9.3.1	Warnings for hydraulic connections .....	131
9.3.2	Type of hydraulic quick couplings.....	131
9.3.3	References for correct connection.....	131
9.3.4	Push-Pull couplings connection.....	132
9.3.5	Flat-Face couplings connection.....	134
9.3.6	Closed centre distributor: Relieve the pressure by pressing the pressure relief button * .....	135
9.4	Electrical Connections.....	135
9.4.1	Warnings for electrical connections.....	135
9.4.2	Procedure for connecting electrical connections .....	136



9.5	Equipment removal .....	137
9.5.1	Electrical connections removal .....	137
9.5.2	Push-Pull couplings removal .....	138
9.5.3	Flat-Face couplings removal .....	139
9.6	Forks.....	141
9.6.1	Identification.....	141
9.6.2	Description .....	141
9.6.3	Installation.....	143
9.6.4	Forks check.....	144
9.6.5	Forks use.....	146
9.6.6	Forks adjustment .....	147
9.6.7	Fork extensions.....	148
9.6.8	Forks safe working procedures .....	150
9.7	Bucket.....	153
9.7.1	Buckets identification .....	153
9.7.2	Buckets description .....	153
9.7.3	Buckets safety stickers.....	153
9.7.4	Bucket use.....	153
9.7.5	Fixed tilt indicator use .....	154
9.7.6	Movable tilt indicator use * .....	155
9.7.7	Buckets Safe Working Procedures .....	155
9.8	Equipment lifting .....	157
9.9	Equipment transport .....	157
<b>10</b>	<b>Emergency procedure .....</b>	<b>158</b>
10.1	Emergency procedure list.....	158
10.2	Vehicle towing .....	159
10.2.1	Vehicle towing with electrical panel on.....	159
10.2.2	Towing the machine with engine in failure .....	160
10.3	Man basket recovery in case of failure for Hercules .....	160
<b>11</b>	<b>Maintenance.....</b>	<b>163</b>
11.1	Maintenance warnings .....	163
11.1.1	Avoid accidents during maintenance .....	163
11.1.2	Personal protective equipment for maintenance.....	165
11.2	Preliminary maintenance operations .....	166
11.2.1	Prepare the vehicle in the "Maintenance position" .....	166
11.3	Engine hood opening.....	166
11.4	Under chassis protection plate removal.....	167
11.5	Battery.....	167
11.5.1	Low maintenance batteries.....	168
11.5.2	"Zero" maintenance batteries.....	168
11.5.3	Battery: Instructions for recharging.....	168
11.5.4	Battery isolation switch.....	168
11.5.5	Battery: Replacement .....	169
11.5.6	Start up with auxiliary batteries.....	169
11.6	Fuel.....	170
11.6.1	Specifications for recommended fuel .....	170
11.6.2	Cleaning and storing fuel.....	170
11.6.3	Refueling .....	171
11.6.4	Fuel tank: Cleaning .....	171
11.7	Safety stickers: Inspection.....	171
11.8	Lubrication .....	171
11.9	Engine maintenance.....	172

11.9.1 Belts: Check and adjustment .....	172
11.9.2 Engine oil: Check and filling up.....	172
11.10 Air filter: Cartridges cleaning and replacement .....	173
11.11 Radiator maintenance .....	174
11.11.1 Air recirculation grids and nets .....	174
11.11.2 Radiator: Checking and cleaning.....	175
11.11.3 Radiator: Liquid filling up and replacement.....	175
11.12 Hydraulic system maintenance .....	176
11.12.1 Hydraulic oil: Check and replacement.....	176
11.12.2 Hydraulic oil intake filter: Replacement.....	177
11.12.3 Hydraulic oil return filter: .....	177
11.12.4 Hydraulic oil filter .....	178
11.13 2 speed transmission maintenance.....	178
11.13.1 Oil change: Inspection.....	178
11.13.2 Oil change: Check and replacement .....	178
11.14 Brakes maintenance.....	179
11.14.1 Brake: Inspection .....	179
11.14.2 Brake: Coolant level check .....	179
11.15 Wheel maintenance .....	180
11.15.1 Epicycloidal reduction gear oil: Check and replacement .....	180
11.15.2 Wheel nuts tightening .....	180
11.15.3 Tyres.....	181
11.16 Lighting .....	182
11.16.1 Headlight .....	182
11.16.2 Tail light .....	183
11.16.3 Work light * .....	184
11.16.4 Led work light* .....	184
11.17 Window washer fluid tank.....	185
11.18 Ventilation system maintenance.....	185
11.18.1 Cab ventilation filter: Cleaning and replacement .....	185
11.18.2 Air conditioning: Cleaning * .....	186
11.19 Boom maintenance .....	187
11.19.1 Sliding blocks maintenance .....	187
11.19.2 Boom lubrication with grease .....	187
11.20 Cylinders block valves maintenance.....	187
11.21 Differential Axles Maintenance.....	189
11.21.1 Differential axles oil: Check and replacement .....	189
11.22 Hydraulic fittings tightening torques .....	190
11.23 Torque specifications - fasteners.....	191
11.23.1 Torque specifications - fasteners: Fine pitch.....	191
11.23.2 Torque specifications - fasteners: Coarse pitch.....	193
<b>12 Technical assistance service.....</b>	<b>195</b>
12.1 Spare part supply .....	195
12.2 Assistance to owner / operator.....	195
12.3 Technical Assistance Service address .....	195
<b>13 Problems diagnostics .....</b>	<b>196</b>
13.1 Engine .....	196
13.2 Hydraulic transmission system .....	196
13.3 Brakes .....	197
13.4 Steering wheel .....	197

13.5 Telescopic boom .....	197
<b>14 Cleaning .....</b>	<b>199</b>
14.1 Machine cleaning .....	199
14.2 Glasses cleaning .....	199
14.3 Cleaning the cab .....	199
14.4 Safety stickers cleaning .....	199
<b>15 Lifting the vehicle .....</b>	<b>200</b>
<b>16 Transporting the vehicle on a trailer .....</b>	<b>201</b>
<b>17 Storing the vehicle .....</b>	<b>202</b>
17.1 Long period of inactivity .....	202
17.2 Long period of inactivity .....	202
17.3 Restarting the vehicle .....	202
<b>18 Waste disposal .....</b>	<b>203</b>
18.1 Ecological considerations .....	203
18.2 Protect the environment .....	203
<b>19 Demolition .....</b>	<b>204</b>
<b>20 Wiring diagram .....</b>	<b>205</b>
20.1 Components legend .....	205
20.2 Wiring diagram sheets .....	210
20.3 Fuse box .....	222
20.4 Engine compartment fuses .....	223
<b>21 Hydraulic diagram .....</b>	<b>224</b>
21.1 Components legend .....	224
21.2 Hydraulic diagram .....	225
<b>22 Technical data .....</b>	<b>226</b>
22.1 Hercules 120.10 .....	226
22.1.1 Equipment .....	231
22.2 Hercules 100.10 .....	232
22.2.1 Equipment .....	238
22.3 Environmental conditions .....	239
22.4 Electromagnetic Interference .....	239
22.5 Radiations .....	239
22.6 DIECI Hydro Telehandler Fluid ISO46 .....	240
22.7 DIECI Hydro Telehandler Fluid ISO32 .....	241
22.8 Declaration of conformity for F-Gas .....	242
22.9 Forks technical data .....	243
22.10 Buckets technical data .....	245
22.11 Tires data .....	246
<b>23 Control and maintenance logs .....</b>	<b>247</b>
23.1 Type of logs .....	247
23.1.1 Control log .....	247
23.1.2 Maintenance Log .....	247

---

23.2	Instructions for compiling the logs .....	247
23.2.1	Warnings on the control log .....	247
23.2.2	Warnings on the maintenance log .....	247
23.2.3	Logs compiling .....	247
23.2.4	Logs legend.....	248
23.2.5	Intervals legend .....	249
23.3	Periodic checks and recording mode (Italian only) .....	250
23.4	Obligation and how to report to I.N.A.I.L. (National institute for insurance against accidents at work) (Italy only) .....	250
23.5	Control log.....	251
23.6	Maintenance log .....	261

# Definitions

## Attachment holding plate

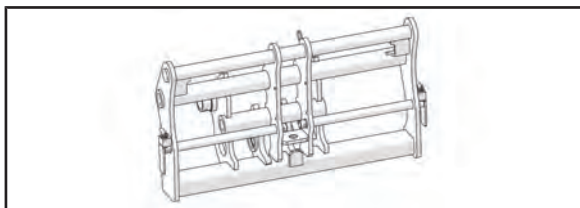

The attachment holding plate is the interface between the vehicle (telehandler) and the interchangeable equipment. The attachment holding plate is placed at the end of the telescopic boom and is used for the quick and safe installation of the interchangeable equipment at the vehicle base.

## Back

The back is the side that is in back of the operator in the control position during the normal forward travel of the vehicle.

## Equipment

The equipment is an interchangeable device that can be installed by the operator on the attachment holding plate of the machine, in order to change the function of the vehicle.

## Front

The front is the side that is in front of the operator in the control position during the normal forward travel of the vehicle.

## Generic maintenance technician

Trained and educated person to perform routine maintenance interventions with basic mechanical, electrical and hydraulic knowledge.

## Left side

The left side is the side that is located to the left of the operator in the control position during the normal forward travel of the vehicle.

## Operator

Instructed person, trained with specific theoretical-practical course concerning use of the vehicle or equipment.

## Right side

The right side is the side that is located to the right of the operator in the control position during the normal forward travel of the vehicle.

## Specialized maintenance technician

Trained and educated person to perform routine and extraordinary maintenance interventions with in-depth and specific mechanical, electrical and hydraulic knowledge, normally sent or authorized by DIECI s.r.l. or the dealer.

## Tool

Category of interchangeable equipment not provided with movable parts such as forks or buckets. No CE marking is required for tools.

## Vehicle

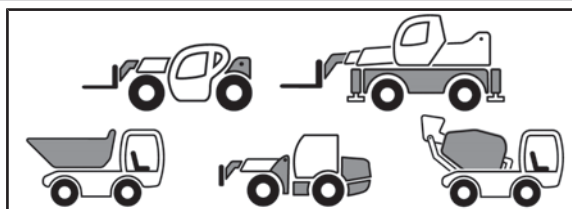

Vehicle means a work vehicle provided with an engine for operation. The term "vehicle" or "basic vehicle" are indistinctly used.

## 2.1 - Manual structure

This manual is an integral part of the official documentation of the Vehicle, Equipment and Tool. It must be carefully stored and be available to the managers, the users and personnel in charge of maintenance.

## 2.2 - Purpose and content

This manual is an integral part of the official documentation and is aimed at supplying the Operator with all the information required concerning technical aspects, operation and safety during the entire lifespan of the vehicle or equipment.



### ATTENTION

This manual should be read carefully before the first use or before maintenance.



### NOTE

If in doubt on the correct understanding of the instructions, contact the Manufacturer for clarifications.

## 2.3 - Preservation

The instruction manual must be kept near the equipment available to the Users (in the cab or on the equipment where set up) inside a dedicated envelope, protected from liquids and anything that might make it illegible.

If the manual becomes creased and/or be, even partially, damaged or illegible or in case of loss of the manual, it must be replaced immediately by contacting the **Dieci Technical Assistance Service**, giving the details of the manual found on the first page of the manual.

## 2.4 - Recipients

This manual is addressed to the following persons:

- Operator : instructed person, trained with specific theoretical-practical course concerning use of the vehicle or equipment
- Generic maintenance technician : trained and educated person to perform routine maintenance interventions with basic mechanical, electrical and hydraulic knowledge

- Specialized maintenance technician : trained and educated person to perform routine and extraordinary maintenance interventions with in-depth and specific mechanical, electrical and hydraulic knowledge, normally sent or authorized by **DIECI s.r.l.** or the dealer.



### ATTENTION

The users must not carry out operations reserved for maintenance technicians or qualified technicians. The Manufacturer is not liable for damage deriving from the non-compliance with this prohibition.

## 2.4.1 - Training

This manual gives the users all technical data on the vehicle or on the equipment, the presence and type of control and safety devices and the presence and meaning of the safety stickers and plates.

All vehicle or equipment users must have all necessary information, training and education in relation to the correct use conditions of the means and foreseeable anomalous risks.

The information, training and educating must be implemented upon introduction of new work equipment and for each work equipment available to users.



### NOTE

Ensure to respect the current laws and Standards in the selling country of the vehicle with regard to information, training and educating of personnel to use the vehicle and its equipment.

The employer is obliged to inform personnel on the following topics related to safety during use:

- Risk of injury
- Vehicle and equipment safety devices set up for operator safety
- Individual safety devices set up for operator safety
- General accident-prevention rules and/or foreseen by international directives
- Accident-prevention rules of Legislation of the Country where the vehicle or the equipment is intended for use

The operator, before starting the work, must know the characteristics of the vehicle and equipment and must have fully read this Use and Maintenance Manual.

**2.4.2 - Training**



**ATTENTION**

The operator in charge of using the vehicle or equipment must have attended a suitable theoretical-practical course lasting as long as indicated by legal prescriptions in the Country where the vehicle or equipment is used.

Training must at least include the following subjects:

- Use and limits of the functioning and emergency controls of the equipment and of the vehicle on which the equipment is mounted
- Knowledge and awareness of the Use and Maintenance Manual and of the control marks, of the instructions and of the warnings applied on the vehicle
- Knowledge and understanding of the Standard on this equipment, including the educating aimed at recognizing and avoiding potential dangers at work
- Knowledge of the mechanical functioning of the vehicle sufficient for recognizing a real or potential failure
- Hints on constructive particulars of the vehicles and on static and dynamic stability concepts
- Correct use of the vehicle procedures in safe conditions with regard to the work place and the load to be handled/lifted, capacity and guide notions
- Knowledge and use of the PPE to be worn during use of the vehicle and of the equipment
- Knowledge and execution of the routine maintenance to be carried out

Training must be carried out under the supervision of a qualified person in an open area and free from obstacles. At the end of this practice, the trainee must be able to safely use the equipment, and the vehicle on which it is installed.

The operator must also be trained on the responsibility and authority of not using the vehicle or equipment in case of failure or presence of unsafe conditions, and request further information from the Manufacturer or authorized dealer.

**2.4.3 - Qualification**

The vehicle and equipment are intended for professional use; their use must therefore be entrusted to qualified figures, in particular:

- Being of adult age
- Be physically and psychically suitable to carry out particularly difficult technical work

- Have been adequately trained on the use and maintenance of the vehicle and equipment
- Have been judged suitable by the employer to carry out the work entrusted to them
- Are able to understand and interpret the manual and the safety requirements
- Know the emergency procedures and their activation
- Have the ability of activating the specific type of vehicle or equipment
- Are familiar with the specific standards of the case
- Have understood the operational procedures defined by the Manufacturer of the vehicle or equipment

**2.5 - Classification of dangers**

Carefully read the safety regulations given and follow all recommended precautions in order to avoid potential risks and safeguard your health and safety.

The symbols listed below are inserted to highlight situations which **DIECI S.R.L.** considers particularly important.

If in doubt, contact your agent or dealer.



**DANGER**

It indicates an imminently hazardous situation which, if not avoided, could result in death or serious injury.



**WARNING**

It indicates a potentially hazardous situation which, if not avoided, could result in death or serious injury.



**ATTENTION**

It indicates a potentially hazardous situation which, if not avoided, could result in minor or moderate injury.

**ATTENTION**

Used without the safety warning symbol, it indicates a potentially hazardous situation which, if not avoided, could result in property damage.

**NOTE**

It indicates information or a company policy that relates directly or indirectly to personnel safety or to property protection.

**NOTE**

It indicates an optional accessory or attachment.

**2.6 - Machine general warnings**

Every vehicle or equipment comes with a copy of its own manual.

**ATTENTION**

Reproduction of all or part of the contents of this manual or of the multimedia attachment, if any, is prohibited.

*Dieci s.r.l.* will protect the ownership rights of these materials.

**ATTENTION**

It is compulsory to read and understand this manual before using the vehicle or various equipment and to carefully follow the indications therein. The instructions for use, maintenance and repair described in this handbook must be followed if the vehicle is to be considered as being operated in accordance with the manufacturer's intended uses.

**NOTE**

*DIECI s.r.l.* reserves the right to carry out possible modifications to the vehicle or equipment for technical or commercial reasons without prior notice.

- A copy of the use and maintenance manual relative to vehicle parts or equipment of the respective suppliers can be supplied. These

manuals are written by the respective product suppliers and reproduced accurately and in full by *DIECI s.r.l.* with their specific authorization: they can be enhanced with further specifications drawn up by *DIECI s.r.l.*

- This Use and Maintenance manual is also provided by the Dealer upon delivery of the vehicle, in order to make sure that these instructions are read and correctly understood. Should you have trouble understanding any part of this manual, do not hesitate to contact your nearest Dealer for clarification.
- All documentation provided constitutes an integral and important part of the product and must always be available to users.
- The instructions for use, maintenance and repair described in this handbook must be followed if the vehicle is to be considered as being operated in accordance with the manufacturer's intended uses.
- This manual assumes that the health and safety standards in the work place, in force in the place of use of the vehicle and of the equipment, are complied with.
- This Use and Maintenance Manual in the user's language, must be carefully stored on the vehicle at all times in an accessible and well known place to all users. If the manual becomes creased and/or be, even partially, damaged or illegible or in case of loss of the manual, it must be replaced immediately by contacting the Dieci Technical Assistance Service, giving the details of the manual found in the "Introduction" chapter.
- Improper, incorrect, or irrational use of the vehicle or the accessories with which it is equipped as well as modification to its physical structure or functioning is prohibited. A different use is strictly prohibited and relieves *DIECI s.r.l.* from responsibility for damage caused to persons, things or animals.
- *DIECI s.r.l.* is not liable for damage caused by negligent use of this vehicle or the accessory even if said damage is not a result of intentional improper use. Everything possible has been done during the design and construction phases of vehicles and equipment to make your job as safe as possible. Due caution, however, is indispensable and there is no better rule to prevent accidents.
- To correctly use the components and vehicle controls recalled in the following pages, refer to the specific use and maintenance manual of the vehicle.



- If the vehicle or the equipment must be used in particularly severe conditions (for example: In dusty environments or worksites, on argillaceous or muddy terrain), we advise consulting your nearest dealer for specific instructions. Failure to observe these instructions may result in the vehicle's guarantee being voided.



### WARNING

For your safety and the safety of others, do not change the structure or adjustment of the various components of the vehicle or equipment.



### NOTE

The right and left positions indicated in this manual refer to the view of the operator sitting in the driver's seat (looking forwards).

## 2.7 - Equipment general warnings



### WARNING

**Only equipment CE certified by the relative manufacturer can be used on DIECI vehicles, as well as equipment approved or falling within the technical limits set out by DIECI S.r.l.**

Before commissioning any kind of accessory make sure about its compatibility with the operating vehicle and about the calibration of the safety system related to the accessory used.

*DIECI S.r.l.* liability shall not be involved if equipment use or modifications do not comply with the above mentioned requirements.

## 2.8 - Intended use

The vehicle or equipment described in this document must be used only for the purposes set out in this Use and Maintenance manual.

Adherence to and strict compliance with the terms of use, repair and maintenance, as specified by the Manufacturer, are essential elements covered by the intended use.



### WARNING

The vehicle and equipment must be used **ONLY** by trained and qualified staff who is aware of the information contained in this Manual.

## 2.9 - Contraindications for use

The vehicle or equipment must **NOT** be used:

- For recipients other than those listed in the "Recipients" chapter
- For uses other than those mentioned in this manual
- In environmental conditions other than those listed in chapter "Environmental Conditions"
- In use on the road, use the vehicle only if in possession of a valid driver's license in accordance with the regulations in force in the country of use
- Do not use the movable hydraulic parts of the vehicle to lift persons (except with special man baskets)



### NOTE

For any other use of the vehicle or equipment, other than those mentioned above, the Manufacturer will reserve the right to revise the terms of the warranty.

## 2.10 - Declaration of first test

### Manufacturer's declaration of first test

*DIECI s.r.l.* declares that each machine and equipment manufactured at its plants, before placing on the market, has been subjected to static and dynamic tests designed to verify proper operation and compliance with EU directives to which it is subject.

At the conclusion of the tests performed, the CE certification of the tested machine will be issued.

Each *DIECI s.r.l.* product with CE marking is provided with the related certificate, which must be kept by the rightful owner according to the requirements of law.

## 2.11 - Liability

- The vehicles and equipment are built according to the EC Directives in force at the time of sale;

- Failure to follow the instructions for use and safety or the use of the vehicle in good working order can not cause accidents criminal offense;
- The manufacturer is not liable for damage caused to persons, animals or property resulting from improper use of the vehicle or equipment or from unauthorized structural changes, applications, and transformations;
- The Manufacturer also reserves the right to make any changes to the vehicle or equipment for any technical and commercial requirement without notice.

## 2.12 - Manufacturer

### DIECI s.r.l.

Via E. Majorana, 2/4  
 42027 Montecchio Emilia (RE) ITALY  
 Tax Code 01283560686 VAT No. 01682740350  
 Tel. +39 0522 869611 - Fax +39 0522 869744  
 email: info@dieci.com

## 2.13 - Vehicle identification label

The identification label (fig. 160550-1) shows the main identification data of the vehicle

**NOTE! Refer to the "Identification" chapter of the vehicle use and maintenance manual to know the position of the label in the cab.**

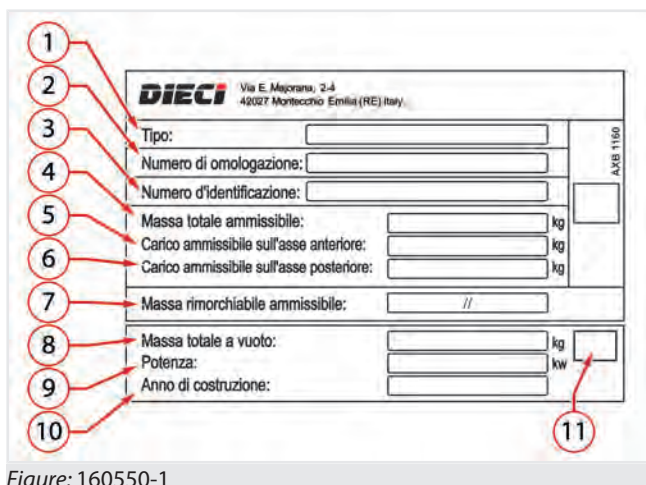

Figure: 160550-1

1	Type	.....
2	Homologation number	.....

3	Identification number	.....
4	Total permissible mass (kg)	.....
5	Permissible load on the front axle (kg)	.....
6	Permissible load on the rear axle (kg)	.....
7	Permissible towable mass (kg)	.....
8	Total unladen mass (kg)	.....
9	Power (kW)	.....
10	Year of construction	.....
11	CE Marking (if installed)	.....

To ensure a prompt and efficient service when ordering parts or when requesting information or technical clarification always specify the identification details.

Therefore we recommend to note the data relating to the accessory in your possession in order to safely and quickly identify them in the future, in case of need.

## 2.14 - Certification and CE marking

The vehicle and related equipment are manufactured in accordance with the relevant EU directives and applicable at the time of its release on the market.

L'analisi di all the essential safety health and requirements was carried out during the design and construction in order to verify the applicability and the consequent compliance. Where the analysis has detected an initial lack of conformity, the problems were corrected with appropriate solutions in order to satisfy these requirements.

Here following is shown a facsimile of the certification attached to the vehicle.



---

**DICHIARAZIONE DI CONFORMITA' CE**

**CE**

(Direttiva macchine 2006/42/CE, allegato II, parte A -Direttiva compatibilità elettromagnetica 2014/30/UE, allegato IV)

**Prodotto:** \*\*\*\*\*

**Nome del Fabbricante:** DIECI S.r.l.  
**Indirizzo:** Via E. Majorana, 2-4 - 42027 Montecchio Emilia (RE), Italia

**La presente dichiarazione di conformità è rilasciata sotto la responsabilità esclusiva del fabbricante.**

**Oggetto della dichiarazione:**  
 Il carrello elevatore telescopico Tipo B\*\*\*\*\* (\*\*\*\*\* Matricola B\*\*\*)\*\*\*\*\*

**L'oggetto della dichiarazione di cui sopra è conforme alla pertinente normativa di armonizzazione dell'Unione:**

- Direttiva Macchine - 2006/42/CE
- Direttiva Compatibilità elettromagnetica - 2014/30/UE
- Direttiva sull'emissione acustica ambientale delle macchine - 2000/14/CE procedura allegato VIII

**Organismo notificato Dir.2000/14/CE:** NB 0303 - ICE Istituto Certificazione Europea SpA, Via Garibaldi 20 - 40011 Anzola dell'Emilia (BO)

**Informazioni supplementari:**

**Nome e indirizzo della persona autorizzata a costituire il fascicolo tecnico:**  
 SIG. ENNIO MANGHI  
 presso DIECI S.r.l. - Via E. Majorana, 2-4 - 42027 Montecchio Emilia (RE), Italia

Potenza netta installata: \*\*\* kW  
 Livello di potenza sonora misurata: L<sub>WA</sub> = \*\*\* dB(A)  
**Livello di potenza sonora garantita:** L<sub>WA</sub> = \*\*\* dB(A)

Targa riportante marcatura CE è applicata sulla macchina.  
**Firmato a nome e per conto di:** Ennio Manghi, Amministratore di DIECI S.r.l.

**Montecchio Emilia \*\*\*\*\***

**DIECI SRL**  
**Via E. Majorana, 2-4**  
**Montecchio Emilia (RE)**  
 Un Amministratore





Via E. Majorana, 2-4 • 42027 Montecchio Emilia • (Reggio Emilia) ITALY  
 Tel. +39 0522 869611 - Fax +39 0522 869798 (Reception) - Fax +39 0522 869797 (Atm. nat.)  
**www.dieci.com** • E-mail: info@dieci.com  
 Cap. Soc. Int. Vers. € 10.000.000,00 Reg. Imp. R.E. N. 01283500686 R.E.A. R.E. N. 204278 - C.F. 01283500686 • P.I. 01682740350

## 2.15 - Units of measurement and abbreviations used

DECIMAL METRIC SYSTEM (IS)		ENGLISH IMPERIAL SYSTEM (IMP)	
NAME	SYMBOL	NAME	SYMBOL
<b>SURFACE</b>			
square meter	m <sup>2</sup>	square foot	ft <sup>2</sup>
<b>ELECTRICITY</b>			
Ampere	A		
Volt	V		
<b>FORCE</b>			
kiloNewton	kN		
Newton	N		
<b>FORCE TIMES LENGTH - TORQUE</b>			
Newton-meters	N·m	pounds inch	lb-in
<b>FORCE TIMES SURFACE AREA - PRESSURE</b>			
kilopascal	kPa	pound/square inch	psi
<b>ROTATION FREQUENCY</b>			
Revolutions per minute	rpm		
<b>LENGTH</b>			
kilometer	km	mile	mi
meter	m	foot	ft
centimeter	cm	inch	in
millimeter	mm	inch	in
<b>MASS</b>			
kilogram	kg	pound	lb
ton	t	pound	lb
<b>POWER</b>			
kilowatt	kW	horse power	hp
Watt	W		
<b>TEMPERATURE</b>			
degrees Celsius	°C	degrees Fahrenheit	°F
<b>SPEED</b>			
kilometers per hour	km/h	miles per hour	mph
meters/second	m/s	feet/second	ft/s
<b>VOLUME</b>			
cubic meter	m <sup>3</sup>	cubic yard	yd <sup>3</sup>
		cubic inch	in <sup>3</sup>
liter	l	UK gallon	UK gal
<b>TIME</b>			
hour	h	hour	h
minute	min	minute	min
second	s	second	s

**VOLUME TIMES TIME**

cubic meter per minute	m <sup>3</sup> /min	cubic foot per minute	ft <sup>3</sup> /min
liter per minute	l/min	UK gallon per minute	UK gal <sup>3</sup> /min

**SOUND POWER AND ACOUSTIC PRESSURE**

decibel	dB		
---------	----	--	--

## 3.1 - Exclusions from the warranty

The warranty does not include:

- All consumables and parts or materials subject to normal wear and tear (e.g. batteries, clutch/brake disks, lubricants, filters, belts, fuel...);
- All consumables such as oil and fluids;
- Damage and/or breakage deriving from failure to comply with/implement the operations recommended in the periodic maintenance programs illustrated in the "Use and maintenance manual";
- Damage caused by incorrect repair carried out by unauthorized workshops/personnel;
- Damage for lack of production and/or loss of the product;
- Costs for the rental of a replacement vehicle during the vehicle standstill period for repairs under warranty;
- Breakage of all types of glass, windows (doors, rear window, windshield).

## 3.2 - Delivery and installation

The dealer has the obligation to perform a set of operations when the vehicle is delivered to the customer. These include a complete check to ensure that the vehicle can immediately operate, an explanation on the safety regulations and a detailed explanation on the instructions contained in the "Use and maintenance" booklet regarding use of vehicle controls, the vehicle maintenance, starting up and stop operations and the use of all the parts. All people who use the vehicle must participate in the training.

For the period of coverage of your vehicle, check the terms in the warranty certificate.

The warranty consists in the restoration of the efficiency of parts that are unusable or inefficient due to factory defects through their replacement with original spare parts or through no-charge repair; the costs of transport/travel of the vehicle from the final customer to the dealer/importer and/or to its authorized workshops and vice versa are excluded.

The warranty is valid only if the vehicle has been used correctly according to the manufacturer's instructions and has not been tampered with, and is immediately terminated if modifications and/or repairs to the vehicle are carried out by personnel not authorized by DIECI.

The warranty also expires in the following cases:

- Failure to comply with, and carry out, the maintenance schedules and mandatory services prescribed by the manufacturer;
- Changes made without the manufacturer's consent;
- Repairs or maintenance carried out with non-original spare parts;
- Incorrect use of the vehicle;
- Carelessness, accidents, late notification of the defect, improper use of the vehicle, damage caused by prolonged use of the vehicle in conditions of declared failure;
- Improper use of equipment or its incorrect assembly;
- Use of lubricants/fuel with specifications other than those prescribed and recommended by the company DIECI.

DIECI is not liable for damage to the vehicle caused by incorrect use or malfunctions of other equipment connected to the vehicle.

The warranty covers only damage and/or malfunctions of the vehicle without the user being entitled to claim damages for production losses, for presumed or proven damage to equipment connected to the vehicle itself.

## 3.3 - Warranty: duration

The **DIECI s.r.l.** company guarantees its products for 12 months or 1500 hours from the date of delivery to the customer user or to the Dealer/Distributor.

If the vehicle is stored for long periods by the Dealer/Distributor, at the time of sale to the customer the Service Center will reserve the right to verify warranty activation.

## 3.4 - Warranty: commencement

The guarantee is valid from the date the vehicle is shipped from the factory (sales to Distributors or Dealers). When delivery is handled by the Distributor or Dealer, **DIECI s.r.l.** reserves the right to verify that the guarantee start date corresponds to the shipping or delivery date on the transport document of the product being guaranteed, and/or to the invoice date, and can request original copies of these documents.

## 3.5 - Warranty: activation

The guarantee is automatically valid from the date the vehicle leaves the factory (sale to Distributors or Dealers).

## 3.6 - Warranty procedure

The correct use of the vehicle, associated with regular maintenance, can do much to prevent breakdowns. If, however, malfunctions should occur during the warranty period, the following procedure is recommended:

- Immediately inform the dealer from whom the vehicle was purchased, indicating the model and serial number. The end customer has the obligation to report any flaw or defect regarding the vehicle no later than 8 days from its discovery, under penalty of cancellation of the warranty;
- Give your dealer as much information as possible. So he can know the number of hours of service performed, the type of work you are doing and the symptoms of the problem.

Remember that normal maintenance operations, such as brakes/clutch setting up and adjustment, as well as the supply of materials used for servicing (oil, filters, fuel and antifreeze) are not covered by warranty.

## 3.7 - Intervention campaigns for faulty products

The replacement procedures of parts acknowledged to be faulty will be agreed upon by **DIECI s.r.l.** and its distributors/dealers/authorized workshops.

These intervention campaigns can be followed directly by **DIECI s.r.l.** suppliers, who are responsible for supplying the components to be replaced (interventions authorized by **DIECI s.r.l.**).

The above interventions will be preceded by written communication from **DIECI s.r.l.** to its purchasers.

Only **DIECI s.r.l.** can decide the intervention method (repair, replacement or modification).

## 3.8 - Warranty: intervention request

### 3.8.1 - Guarantee: claim

The claim of the faulty part must be made by the Customer, Dealer, Distributor or Authorized workshop and must be sent directly to **DIECI s.r.l.** Customer Service within 8 days from when it is noted.

The claim must include a clear description of the defect and precise references to the vehicle and equipment (type, model, and serial number). This information can be found on the places indicated in the USE AND MAINTENANCE MANUAL.

### 3.8.2 - Obligation of vehicle downtime

If there is a risk that the defect may jeopardize safety and accident prevention or may cause further damage, the vehicle or the equipment must not be used until it has been repaired and tested.

Any change made on the vehicle or equipment involves a reassessment of conformity with the Machinery Directive 2006/42/EC. This procedure also applies in the case of repairs with non-original parts.

In the event of any dispute, exclusive jurisdiction will be held by the Court of Reggio Emilia - ITALY.

## 3.9 - Non-activation, failure to grant, termination

### 3.9.1 - Warranty: failure to grant

The guarantee is not granted:

- If the defect is not reported as described and within the established time limit.
- If the customer does not comply with **DIECI s.r.l.** request to return the faulty parts replaced during the repairs.
- If the customer has not complied with the obligation to stop using the vehicle after making a claim, limited to damages caused by noncompliance.

### 3.9.2 - Guarantee: termination

The guarantee is terminated:

- If the buyer does not fulfill contractual payment obligations.
- If damage has been caused by carelessness, negligence, or by use of the vehicle for purposes not in compliance with specifications provided in the use and maintenance manual (incorrect



manoeuvres, overloading, use of incorrect fuel, poor maintenance, disregard for warning indicator instruments etc.)

- If the defect is a result of applications, equipment, modifications or repairs not authorized by **DIECI s.r.l.** or carried out using poor quality parts. (For this reason, we recommend always using original spare parts).



## NOTE

Refer to the "MAINTENANCE" paragraph for information regarding recommended routine maintenance.

### 3.10 - Final terms

In none of the cases regarding non-activation of the guarantee, it not being granted or being terminated, the buyer cannot request the cancellation of the contract, or compensation, or an extension of the guarantee.

Any guarantee conditions other than those listed above must be agreed upon in writing and signed by both parties.

Unless agreed upon in writing by both parties; **Dieci s.r.l.** does not pay compensation for any type of claim caused by vehicle downtime, such as:

- Replaced or rented vehicles or equipment
- Labor
- Loss of profit



## 4.1 - General warnings

The instructions for use, maintenance and repair described in this handbook must be followed if the vehicle is to be considered as being operated in accordance with the manufacturer's intended uses.



### DANGER

**THE VEHICLES AND EQUIPMENT MAY NOT BE MODIFIED WITHOUT PERMISSION OF THE MANUFACTURER.**

For your safety and the safety of others, do not change the structure or adjustment of the various components of the vehicle or equipment. The same applies to the deactivation or modification of the safety devices present. Any changes made to the vehicle or equipment, releases DIECI s.r.l. from any liability arising from damage or injury.

Every vehicle or equipment must be used, serviced or repaired only by persons who have received training in advance on the vehicle and on safety regulations, in addition to being authorized to use the vehicle or equipment itself.



### NOTE

**The user must always observe the general safety regulations as well as those for accident prevention, such as traffic rules if the vehicle is used on public roads (according to the regulations in force in the country of use).**

**DO NOT USE THE VEHICLE OR THE ACCESSORIES IF YOU ARE UNDER THE EFFECT OF ALCOHOL, DRUGS OR IF YOU HAVE TAKEN MEDICINES THAT MAY MAKE YOU DROWSY OR MAY ALTER YOUR REFLEX AND REACTION TIME.**

DIECI s.r.l. is not liable for loss or damage caused by negligent use of this vehicle or the equipment even if said loss or damage is not a result of intentional improper use. Everything possible has been done during the design and construction phases of vehicles and equipment to make your job as safe as possible. Due caution, however, is indispensable and there is no better rule to prevent accidents.



### DANGER

**THE VEHICLES OR EQUIPMENT IN QUESTION ARE NOT SET-UP FOR USE IN ENVIRONMENTS OR SITES EXPOSED TO THE PRESENCE OF EXPLOSIVE GASES; USE IN THESE PLACES IS PROHIBITED.**

To operate in these environments, the Manufacturer must be contacted so that the necessary modifications can be made to the vehicle and/or equipment.



### DANGER

All functions and procedures concerning the operation and mounting of the vehicle or its equipment that are not described in this manual are strictly FORBIDDEN.



### WARNING

Read all of the safety stickers on the vehicle and on the equipment and observe all regulations printed on these stickers before starting up, running or refueling the vehicle or before carrying out maintenance work. Immediately replace damaged, lost or illegible stickers. Clean them when they are covered by mud, concrete or debris.

- Do not use the vehicle or equipment without having first read and understood all parts of this manual, and without having attended an adequate training course.
- Do not use the vehicle or equipment when hands or shoes are wet or dirty with grease or greasy substances.
- Verify that all safety devices are efficient before using the vehicle or the equipment. The operator must always maintain control of the vehicle and equipment state and operation.
- Use the audible warning device or other signals to alert people in the area before starting up the vehicle.
- Inspect control instruments immediately after start up, while the engine is hot and at regular intervals during use, in order to promptly recognize and resolve any malfunctions.
- Do not use the vehicle or equipment if a danger label or a maintenance in progress label is placed inside the cab.

- Do not carry passengers on the vehicle or in the driver's cab or on any other part of the vehicle (including man basket).
- It is prohibited to use the mobile hydraulic parts of the vehicle to lift people except when using the man baskets with relevant personal protective equipment for the operator inside.
- Regardless of the user's experience, become familiar with the position and function of all controls and instruments in a work area free from obstacles and persons, before operating the vehicle or the equipment.
- Carry out all the described safety checks before resuming operations.
- While the vehicle is running, always keep light signals on. These serve to warn people that the vehicle is about to move.
- Always keep the safety distance adequate for the type of work and persons or objects in the work area. Always look in the travel direction and maintain good road visibility.
- Adjust movement speed based on the load carried and the type of ground; remain at low speeds to reduce the risk of the vehicle tipping over or losing the load.
- Do not drive with the brake pedal pressed.
- Do not use the vehicle force of impact to carry out tasks. These vehicles are not designed for said use; therefore, such use may cause vehicle overturning, damage, the breakage of components and attachments, or serious personal injury for the user.
- Always operate with the engine hood closed.
- Do not operate with the vehicle protective parts removed.
- When working in a congested area, designate one person to signal and coordinate the work zone.
- Make sure that everyone follows the directions given by the person in charge of signaling.
- Make sure to use signals that conform with the provisions in force in the country of use of the vehicle.
- For additional information with regard to the presence of a person in charge of signaling, consult the "Signals to more vehicles" chapter.
- When working alongside excavations or on the edge of the road or soft ground, keep at a safe distance as the vehicle may overturn.
  - Designate a person on the ground to be in charge of signaling.
  - Remember that after heavy rain, the use of explosives or an earthquake, the ground is more fragile.
- When working on the upper part of or inside buildings or other structures, verify their capacity and stability before starting operations. The risk of collapse exists and can cause serious injuries or damage.
- Working on a slope may be dangerous. The conditions of the terrain may vary according to climatic conditions (e.g. rain, snow, ice). Therefore, pay careful attention to the conditions of the terrain on which the vehicle is being used; the use of low speeds is recommended.
- Drive slowly on grass, leaves or wet steel slabs. Even when operating on slight slopes the vehicle may slip or lose balance with risk of tipping.
- Tipping conditions of the vehicle can vary depending on the features of the ground, environmental conditions and the type of work. Complying with all the safety instructions contained in this manual reduces risks for the vehicle and the operator in most operating conditions provided herein.
- It is forbidden to use the tractor if there is any risk of tipping that is not covered herein, as this manual contains an incomplete list.

## 4.2 - Safety indications



### ATTENTION

Carefully observe and follow all safety signals on the vehicle and on the equipment and read all safety messages in this manual.

- The safety messages in this chapter illustrate the basic safety procedures of the vehicles and equipment.
- The safety signals must be installed, maintained and replaced when necessary.
- If a safety signal or this manual is damaged or missing, order a replacement from the **DIECI s.r.l.** dealer in the same way in which spare parts are ordered (be sure to communicate the model and serial number of the vehicle when placing the order).
- Learn how to correctly and safely operate the vehicle and the equipment and their relative controls.
- Allow only trained, qualified and authorized personnel to operate the vehicle and installed equipment.
- Keep the vehicle, equipment and accessories in appropriate working conditions.

- Unauthorized modifications to the vehicle, to the equipment or accessories can jeopardize their operation and/or safety and influence their lifespan.
- In case of doubt, contact the manager before proceeding to operate or carry out maintenance work on the vehicle or on the equipment.

### 4.3 - Personal protective equipment

In some cases, when working in particularly uncomfortable environments, adequate clothing or equipment must be worn.

It is mandatory for the operator, before starting to work, to learn from the safety manager or the site manager which are the possible risks of the work and which accident prevention clothes he must wear.



#### ATTENTION

**Always use PPE that is appropriate for the type of work to be performed.**

The Personal Protective Equipment used by the operators can have different characteristics, depending on the type of construction site and risks present in the work place.



#### ATTENTION

**Keep the personal protective equipment in good conditions.**

Accident prevention clothes must always be intact and in good condition. Damaged clothing cannot ensure adequate protection. Do not wear damaged clothing; always replace damaged or torn clothing before operating the vehicle.

#### 4.3.1 - Protective clothing

Icon	Refilling	Description
	ISO7010: M004	Wear protective goggles
	ISO7010: M008	Wear safety shoes
	ISO7010: M009	Wear protective gloves
	ISO7010: M015	Wear high visibility clothing

Icon	Refilling	Description
	ISO7010: M013	Wear a protective mask (for work in dusty environments)
	ISO7010: M017	Use a protective breathing apparatus (for work with dangerous substances)
	ISO7010: M018	Wear a safety harness



#### DANGER

##### Danger of crushing

Pay attention to moving parts to avoid danger of crushing or dragging of the lower and upper limbs. Avoid wearing jewelry or pendants that might be trapped in moving parts. Long hair must be tied back to avoid it being caught in moving parts.

Do not wear loose clothing, chains, belts or other accessories that may be caught in the control levers or in other parts of the vehicle or equipment.

#### 4.3.2 - Protect yourself against noise

Prolonged exposure to loud noise can damage your hearing or may cause hearing loss.

Icon	Reference	Description
	ISO7010: M003	Wear hearing protection



#### ATTENTION

Always wear anti-noise earmuffs or earplugs to protect yourself from excessive and irritating noise.

### 4.3.3 - Protections against objects falling from height

Icon	Reference	Description
	ISO7010: M014	Wear a helmet



## DANGER



### Danger of falling objects

Use of a safety helmet is required if there is a risk of falling objects.

### 4.3.4 - Protect yourself from flying fragments

Icon	Reference	Description
	ISO7010: M013	Wear a face shield



## WARNING

During operation in certain conditions, particles of material may be ejected. In such conditions, it is a good idea to wear protective goggles and clear the area of those people not in possession of such goggles.

## 4.4 - Preparing for accidents

- Always be prepared in the event of a fire or an accident.
- Keep a fire extinguisher and first aid kit at hand. (Not supplied by the manufacturer, "optional accessories").
- Carry out periodic inspections to ensure that the first aid kit contains all necessary items; replenish content if necessary.
- To properly use the extinguisher, carefully read the instructions located on the extinguisher.
- Carry out periodic inspections and maintenance (six monthly) to ensure that the extinguisher is ready for use at any given moment.

- Create priority procedures to deal with fires or accidents.
- Keep emergency telephone numbers (doctors, ambulance, hospital and fire brigade) clearly visible and near the telephone.
- Adequately trained and educated personnel must be present for managing emergencies with adequate theoretical-practical course carried out on site.

Below are some First Aid procedures that can be activated in case of accident following use of the vehicle or equipment object of this use and maintenance manual.

These procedures may be useful in an emergency for the users or other operators present near-by, during use and various life phases of the vehicle or of the equipment (transport, installation, use, maintenance, adjustment, etc.).

### 4.4.1 - First Aider Tasks

1. Activate first aid (emergency call).
2. Evaluate the victim and, if necessary, support vital functions.
3. Stop an external hemorrhage.
4. Protect wounds and burns.
5. Protect the victim against further damages.
6. Do not perform unnecessary or damaging actions, such as giving beverages, moving the victim, reducing dislocations and/or fractures, etc.

### 4.4.2 - Emergency call

Good first aid intervention also depends on the timely arrival of rescuers (emergency medical support) to the place of the emergency.

This is why the first aider in charge of calling the emergency must precisely indicate:

- Address of where the accident or illness took place.
- Number of injured or ill persons.
- The possible cause of the event.
- The state of the vital functions of the injured party, specifying whether the same is conscious or not and breathes normally or not.

At the end of the call it is recommended to:

- Give own details, indicating a telephone number where to be contacted.
- Wait for rescuers in an easily accessible and visible location.

**4.4.3 - Traumas**

**Distortions, dislocations and fractures:**

Immobilize the joints in the position after the trauma, using bandages or splints, supporting the analgesic position of the injured party without attempting dangerous manoeuvres. Apply the cold (with bag of ice or other systems). In case of exposed fracture, cover the wound using a sterile gauze pad, after having pressed at a distance on the specific points the relative hemorrhage.

**Contusions, crushing:**

In case of contusions and/or crushing of ends of the upper and lower limbs (fingers, hand, feet, etc.) it is advised to immediately place the limb underneath running water (cold) and apply ice. Also check for wounds and/or cuts in the hit area and, if necessary, disinfect with the due precautions.

**4.4.4 - Hemorrhages**

It is necessary to press the fingers on the hemorrhage point with sterile gauze pad, lifting the limb and eventually compress upstream of the hemorrhage with tourniquet. Wear protective gloves in case of contact with body fluids.

**Treating superficial wounds:**

Carefully expose and clean the wound, disinfect it with physiological solution, medicate it covering it with sterile gauze pads. Bandage avoiding excessive tightening to allow good circulation.

**Treating deep wounds:**

It is a priority to protect yourself against the risk of infection using gloves and splash shield; pad the hemorrhage by direct pressure or using other pressure points until it stops or the arrival of the ambulance. Call the medical emergency number, informing them that you are padding an arterial hemorrhage.

Treat the wound only after the hemorrhage is under control.



**ATTENTION**

Do not use cotton wool, methylated spirit, antibiotic powder to disinfect the wound.

**4.5 - Preventing fires and accidents**

**4.5.1 - Risks of fires**



**DANGER**



**Danger of fire**

It is forbidden to smoke or use naked flames during use and maintenance operation of the vehicle and equipment.



**Do not operate the vehicle or equipment without the following safety conditions:**



**DANGER**

Fuel, oil and lubricant leaks can trigger fires and cause serious injuries.

- Ensure that there are no flammable liquids leaking.
- To avoid oil or diesel leaks, make sure that there are no loose or missing clamps, no twisted tubes and no tubes that rub up against each other.
- Do not bend any tubes/pipes under pressure.
- Never install damaged tubes.
- Do not weld tubes or pipes containing inflammable liquids.
- Do not use a torch head to cut tubes or pipes containing inflammable liquids.



**DANGER**

Short circuits may cause fires.

- Ensure that there are no short circuits.
- Clean and interrupt all electrical connections.
- Check before each work shift that there are no loose, twisted, hardened or damaged wires.



**DANGER**

Fuel, oil, grease, waste, deposits or accumulated dust or other components can cause a fire.

- Remove inflammable materials.
- Prevent fires by inspecting and cleaning the vehicle at every shift, by immediately removing inflammable components.
- Check the ignition switch: in the event of fire, failure to switch off the engine will obstruct the work of the Fire Brigade.



- Do not use naphtha, petrol or inflammable liquids to clean parts of the vehicle. Only use non-flammable detergents.



## DANGER

Safely handle dangerous liquids

- Handle fuel with care, it is easily inflammable. If fuel is ignited, there may be an explosion and/or a fire.
- Do not refuel the vehicle while smoking and in presence of naked flames or sparks.
- Always stop the engine before refueling the vehicle.
- Fill up the tank outside.
- All fuels, most lubricants and some anti-freezes are inflammable.
- Preserve the flammable fluids away from fire hazards.
- Do not burn or drill pressurized containers.
- Do not keep cloths soaked with lubricant; they may cause fires and spontaneous combustions.

### 4.5.2 - Risks of inhaling gas



## DANGER

**Exhaust engine gases are toxic and can cause damages to your health.**

If necessary to work in closed ambients, ensure it is sufficiently ventilated and equip the vehicle with special purifiers.

### 4.5.3 - Risks of batteries exploding



## DANGER

**The gas of the batteries may explode.**

- Keep any sparks, open flames or lit cigarettes away from the upper part of the battery.
- Never place a metal object between the terminals to check the battery charge. Use a voltmeter or a densimeter.
- Do not create sparks in the battery connection during recharging phases or starting the engine with auxiliary battery.
- Do not charge the batteries if they are extremely cold, extremely hot or damages as they might explode.
- The ideal temperature for the recharging of the batteries is 16 °C (60,8 °F).
- The electrolyte in the batteries is an extremely corrosive acid.
- Should the battery explode, the electrolyte may be sprayed in the eyes with the possibility of causing blindness.
- Ensure to be wearing protective goggles when carrying out maintenance on the batteries.
- Do not overturn or tilt the battery as acid could come out.

### 4.5.4 - Residual risks



## DANGER

**Damage may be caused by entanglement in moving parts.**

Keep away from moving parts.



## DANGER

**Avoid burns.**

Stay away from hot parts.

#### Jets of hot fluids:

After operation, the engine cooling liquid is hot and under pressure. Contact with hot water or steam may cause serious burns.

Avoid possible injury caused by hot water jets. Do not remove the radiator cap until the engine has cooled down. To open it, unscrew the cap as far as possible. Before removing the cap, release all of the pressure.

#### Hot surfaces and fluids:

The engine, reduction gears and hydraulic system oil heat up during vehicle use. The engine, rigid and flexible piping and other components heat up.

Wait until all parts cool down before beginning maintenance or repair work.



**DANGER**

**Caution with pressurized fluids.**

Fluids such as fuel or hydraulic oil under pressure can penetrate the skin and eyes causing serious injuries.

Avoid these dangers while repairing or carrying out maintenance on the vehicle, discharging the pressures (using the hydraulic levers of the distributors) before disconnecting or repairing pipes and hydraulic parts.

Before restarting the engine, ensure that all connections have been correctly tightened.

Use a piece of cardboard to check for any leaks; make sure your hands and body are adequately protected against pressurized fluids. Wear a face mask or accident-prevention goggles to protect your eyes.

Should there be an accident, seek medical attention immediately. Any fluids that penetrate the skin must be removed surgically within a few hours to avoid infections.



**DANGER**

**Electrocution**

All maintenance and/or adjustment interventions on powered parts must be carried out only and exclusively by qualified and adequately trained personnel.



**DANGER**

**Risk of slipping.**

During on-site operations, the areas around the equipment may have debris and liquid (oil, water, etc.) that might make the floor slippery. Pay the utmost attention.



**DANGER**

**Risk of falling, tripping.**

Pay the utmost attention when climbing in and out from the vehicle.



**DANGER**

**Crushing of hands and feet.**

The presence of moving parts during functioning can cause risks for the ground operators. During vehicle movements, carefully check no unauthorized person is within the required moving area.

**4.5.5 - Contact with dangerous substances**

- Wear the necessary protective clothing.
- Refer to the safety data sheet of the product used and take appropriate precautionary measures when using the product.
- Avoid contact with skin and eyes
  - In case of contact with eyes: rinse them thoroughly with plenty of water for a few minutes keeping the eyelids open and seek medical attention.
  - Should any fluid come into contact with skin, wash the area carefully, remove contaminated clothing, and when skin is dry, apply moisturizing cream. Consult a doctor if necessary.
  - In the event of inhalation, move away from the contaminated area and go to a well-ventilated location. Consult a doctor in the event of respiratory problems.
  - If swallowed: immediately contact a doctor, showing the label or container. Do not induce vomiting to avoid the risk of inhalation via respiratory passageways.

**4.6 - Storing dangerous liquids**



**DANGER**

**Flammable material danger.**

All fuels, most lubricants and some anti-freeze fluids are inflammable.

Handle fuel with care, it is easily inflammable. If fuel is ignited, there may be an explosion and/or a fire.



**WARNING**

All fluids must be kept out of the reach of children and non-qualified persons.

**WARNING**

Do not store together or mix different types of substances.

**DANGER**

**All chemicals are generally very harmful to health.**

Avoid contact with skin and eyes by wearing appropriate protective clothing; do not swallow.

**DANGER**

**It is forbidden to smoke and have open flames**



It is forbidden to smoke or use open flames near fuels.

**Comply with the following precautions to store dangerous liquids:**

- All inflammable fluids must be stored in special containers, and the content must be clearly indicated on each container. Containers must be tightly sealed.
- Store inflammable fluids in well-ventilated locations, far away from heat sources, sparks and open flames.
- Keep containers closed and covered. Other substances (e.g. foodstuffs) must not be present in this location.
- Always fill up the tank when outdoor.
- Be careful of fumes and vapors which may be formed by chemical products. Avoid inhalation.
- Do not breathe in flue gas.
- Ensure that these chemical products do not spill or flow into the ground, sewers or surface waters. If necessary, inform the competent local authorities.
- In the event of a fire, use carbon dioxide, dry chemical powder, foam, sprayed water, sand, earth. Use jets of water to cool down surfaces exposed to the fire.
- Verify that there are no leaks of inflammable liquid (fuel, oil, grease, lubricants in general) in the storage containers.

**NOTE**

Refer to the safety data sheet of the product for additional precautions and warnings that are to be adopted.



## 4.7 - Warnings for safe working

### 4.7.1 - Ensuring the vehicle is clean

- Clean the windows, lights and rear-view mirrors (if installed).
- Clean dirt and waste away from the engine, joints and radiator
- Make sure the cab steps and the handle are clean and dry
- Clean all safety stickers and manoeuvring instructions. Replace any stickers that are illegible or missing



#### WARNING

If the vehicle or equipment is not in perfect working order its operation is strictly prohibited.



#### NOTE

For the cleaning procedures, refer to the "CLEANING" chapter.

### 4.7.2 - Checking for damage

- Make sure that there are no damaged or missing parts.
- Make sure that all articulated pins are properly fastened.
- Make sure that there are no signs of possible cracks or flaws or other damage to the windows (if installed).
- Make sure that there are no oil, fuel or cooling liquid leaks underneath the vehicle.
- Make sure that the wheel bolts are properly tightened.



#### WARNING

If the vehicle or equipment is not in perfect working order its operation is strictly prohibited.

### 4.7.3 - Start working with the vehicle

Regardless of their level of driving experience, operators must familiarize themselves with the position and function of all controls and instruments before operating the vehicle.

- Before using the vehicle, check location of personnel.

- While the vehicle is running, always keep light signals on. These serves to warn people that the vehicle is about to move.
- When working in a congested area, have another person present for signalling.
- When manoeuvring the vehicle, pay attention to bulky vehicle parts. There are parts that jut out from the cab.
- Never use controls for purposes different than those for which they were created for; e.g. to climb on or off from the vehicle or hang clothing, etc...
- Only use the vehicle from the driver's position.
- The vehicle may move suddenly if started up without following the correct procedure, thus, creating the risk of personal injury.
- Start up the engine from the driver's seat only.
- Never start the engine by causing a short circuit between the terminals of the starter motor.
- Before starting the engine, make sure all control levers are in a neutral position.

### 4.7.4 - Passengers transportation

Only the operator must be on board the vehicle, passengers are not admitted.

Passengers may obstruct the operator's view, causing an unsafe operation of the vehicle.



#### WARNING

Carrying people on or lifting people up with the vehicle is strictly prohibited unless the vehicle is equipped with an elevation work platform and has a special certificate of conformity regarding the transport of people.



#### WARNING

It is strictly forbidden to transport persons inside the basket while the vehicle is moving even in the presence of elevation work platform and certificate of conformity. It is compulsory to use the basket only with the parking brake engaged and the outriggers lowered (if present).

### 4.7.5 - Electrical system protection

A burnt fuse must be replaced with another fuse of the same type, amperage and class.

Other types of interventions are not allowed, even if temporary.

Do not connect or remove clamps, fuses, or connectors when the vehicle is switched on or electrically powered.

Any intervention on the electric system must take place with the vehicle not powered electrically. Restore the power supply only after the intervention has been concluded. Remount the lids and protections.

- Use the battery isolation switch to cut off power to the vehicle.
- Cut off power by means of the battery isolation switch even before replacing the vehicle battery.
- In the event that a connector is damaged or is no longer inserted in its housing, replace it immediately in order to avoid short circuits or sparks.

Damaged, pinched or burnt cables must be replaced immediately even if damage is only to the sheathing or outer insulation.

- Never carry out or interrupt any connection on the load circuit, including connections on the battery, with the engine running.
- Never ground (earth) short circuit any charging component.
- Do not use an auxiliary battery with nominal voltage exceeding 12 volt.
- Make sure the polarity is correct when putting in the battery or when using an auxiliary battery when starting the vehicle with cables. Follow the use and maintenance instructions of the manual when starting up the vehicle with cables.

**4.7.6 - Signals to multiple vehicles**

When working requiring more vehicles, give signals normally known to all employed personnel. Designate one person to signal and coordinate the work zone.

**Before operating make sure that:**

- The user and signaller are aware of the hand signals to be able to interact between them
- Everyone follows the directions given by the person in charge of signalling
- The signaller must be easily identified by the user of the vehicle
- The signaller must wear or hold one or more adequate recognition elements, like: jacket, helmet, sleeves, bracelets, signal paddles
- The recognition elements must be bright coloured, preferably of a single colour, and reserved exclusively for the signaller.

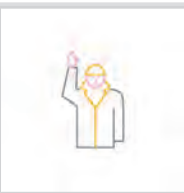
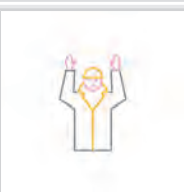
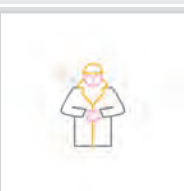
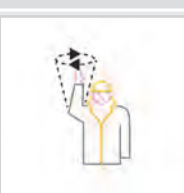
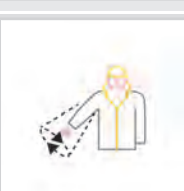
Movement	Meaning	Description
	Start - Attention - Order taking	The two arms are open horizontally, the palm of the hands forward
	Stop - Interruption - End of motion	The right arm is stretched upwards, with palm of right hand forward
	Danger - Stop - Emergency stop	Both arms stretched upwards
	End of operations	The two hands are joint at height of chest
	Lift	The right arm, stretched upwards, with palm of right hand forward, makes a circle
	Lower	The right arm, stretched downwards, with palm of the hand towards the body, makes a circle

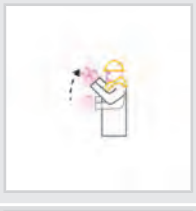
Movement	Meaning	Description
	Vertical distance	The hands, one on top of the other, indicate the distance
	Horizontal distance	The hands, one next to the other, indicate the distance
	Forward	Both arms are folded, the palms of the hands backwards and the forearms make slow movements towards the body
	Move back	Both arms are folded, the palms of the hands forward and the forearms make slow movements away from the body
	To the right compared to operator	The right arm, stretched horizontally, with palm of right hand downwards, slowly makes small movements towards the direction where to move
	To the left compared to operator	The left arm, stretched horizontally, with palm of left hand downwards, slowly makes small movements towards the direction where to move
-	Quick motion	The conventional signals used to indicate movements are quickly made
-	Slow motion	The conventional signals used to indicate movements are made very slowly

### 4.7.7 - Working with the danger of falling masses and objects

When working in areas where there is a risk of falling, bouncing or interference from objects capable of hitting the operator or entering the cab:

- Always close the windows.
- Always ensure that other operators near-by are at a safe distance and cannot be hit by bouncing or falling objects.
- Never carry out work operations under an overhang; this could give way and fall onto the vehicle.
- When working from the cab:
  - Mount suitable safety panels to protect the operator.
  - Always close the windows.
  - Pay careful attention to crumbling walls, landslides, falling material or objects from the installed equipment, that may hit the cab, the protective structure or windows, causing damages to the vehicle and to the operator.
  - Do not excessively weigh down or fill the installed equipment or transport loads that may come out or fall on the ground.
- When working from the passenger basket:
  - Install optionals on the basket such as the roof to provide additional protection to the operators.



#### WARNING

#### Danger of falling objects

Use of a safety helmet is required if there is a risk of falling objects.

### 4.7.8 - Working near electrical lines

Before working near overhead electrical lines, check that the safety distance is sufficient, in compliance with the current Standard in the country of use. In any case, never work near electrical lines at distances shorter than those in the table below or at the minimum distances indicated by the Standards in force in the country of use of the vehicle and of the equipment.

Damp ground may increase the risk of electrocution.

Operating or parking the vehicle too close to electrical cables leads to increased risk of being struck by lightning or being seriously injured.

Designate someone on the ground to signal when too close to power lines.

Do not allow anyone near the vehicle when working in the vicinity of power lines. To prepare for any possible emergency situation, wear rubber shoes and gloves, cover the seat with a rubber piece of fabric and take care not to touch the chassis with any unprotected body parts.



#### DANGER

#### High voltage danger

Should the vehicle or the equipment installed on it collide with an electrical cable, the user, to avoid electrocution, must remain inside the driver's cab until certain that the electrical power supply has been properly disconnected.



#### DANGER

#### High voltage danger

If operating close to overhead electrical lines, check the safety distance in the table below, reported in the Italian Legislative Decree 81/08 Enclosure IX. The table is valid if the vehicle is used on Italian territory. However, refer to the Standards in force in the country of use of the vehicle and equipment.

Un (kV)	Distance
≤ 1	3 m (9.84 ft)
1 < Un ≤ 30	3.5 m (11.48 ft)
30 < Un ≤ 132	5 m (16.40 ft)
> 132	7 m (22.96 ft)

### 4.7.9 - Working under the snow

Snow can hide obstacles and objects, and cover holes, dug-out areas and ditches, therefore, proceed with caution.



#### WARNING

Operation of the vehicle if the quantity of snow does not allow for clear distinction of obstacles and possible dangers along the path, is strictly prohibited.

- Take care when clearing snow and do not venture off the main road; that which is hidden at the sides of the road may cause vehicle overturning or damage to various components.
- Surfaces covered by snow or ice are extremely dangerous. Operate with caution, reducing vehicle speed as much as possible and engaging levers slowly.

- Operate with caution. If the vehicle should sink into the snow, it may overturn or remain buried. Do not venture from the road and avoid remaining entrapped or buried under heaps of snow.
- Extra care should be taken, when working on icy terrain. The ice will melt as the temperature rises and the ground will become slippery.
- Use caution in the presence of electrical cables, ditches, or freshly excavated or worked ground.
- Make sure not to cause risk to others in the area when backing up the vehicle.
- Always check the space around the vehicle before carrying out any manoeuvres

- Spaces with dangerous or explosive atmospheres.
- Protected environments such as refineries.



### ATTENTION

**The vehicle must be appropriately modified and certified to work in environments with an explosive atmosphere.**

The vehicle can only be used in a tunnel if it has been declared suitable for these environments.



### NOTE

If working the vehicle at temperatures below -10°C (14°F), empty and refill the tank using lubricants, fuel or cooling liquids suitable for such temperatures.



### NOTE

There are accessories that can be used to facilitate working with ice or snow, contact your dealer or agent.

## 4.7.10 - Working with scarce lighting



### ATTENTION

**The standard illumination of the vehicle is not suitable in working conditions with poor visibility or for use at night.**

The vehicle can only be used with sufficient lighting in the work area.



### NOTE

There are several ways to improve visibility in conditions of poor lighting. Contact your local **DIECI s.r.l.** dealer.

## 4.7.11 - Working in closed areas or dangerous atmospheres

**It is FORBIDDEN to use the vehicle in:**

- Suitably ventilated closed spaces, that are nevertheless not compatible for the use of equipment with running endothermic engines.

**4.7.12 - Reduce vibrations**

Consider the following recommendations to reduce the vibration exposure of the operator:

- Always use the appropriate equipment for the job to be carried out.
- The driver's seat must be properly adjusted to suit the operator needs. Inspect and if required repair the suspensions and the regulation mechanisms of the seat.
- Make sure that the vehicle is kept efficient, perform vehicle maintenance as prescribed in this manual.
- Steer, accelerate, brake, shift gears, move the tool in a non-abrupt way.
- During transfers adjust the speed of the vehicle to minimize the level of vibrations. Reduce speed to avoid the risk of jolting. Transport the vehicle in the event of significant distance between job sites.
- Maintain the workplace in good condition, remove stones and obstacles, fill depressions or holes etc.
- To avoid back pain problems, use the vehicle only in good health.
- Take breaks so as to reduce the time of sitting in the same posture.
- Do not exit the cab or go out of the vehicle with a jerk.
- Avoid to lift and move loads repeatedly.
- Further recommendations to reduce vibration when working with passenger basket:
  - Use the controls smoothly.
  - Do not make any sudden movements on the passenger basket.
  - The vibrations generated by the vehicle are not a source of risk when using the basket.

**4.8 - Working in windy conditions**

Wind speed variation can cause a number of problems including the loss of vehicle stability, load oscillation, and a decrease in visibility due to dust, leaves, etc.

Adverse factors to vehicle use are:

- Location of the work site, the aerodynamic effect of buildings, trees and other structures influence wind speed.
- The height of the extended boom: the higher the boom is raised vertically, the higher wind speed becomes.

- Load bulk area: the more space the load occupies, the more the wind force is felt.

**Strong wind**

*DIECI* telehandlers can be used up to a wind speed of 45 Km/h, equal to 12.5 m/s (No.6 on the Beaufort scale) measured on the ground.

At 10°C temperature, wind with a speed of 32 Km/h it seems that exposed parts of the body have a temperature of 0°C. The higher you climb the faster the wind speed and the more the sensation of pressure drop increases.



**WARNING**

**Strong wind danger**

In the presence of strong winds (no.5 Beaufort scale) never lift loads with surfaces exceeding 1 m<sup>2</sup>.

Below you can find the graph of the Beaufort scale for an indication of the wind speed with which you are working and when to suspend operations, if wind speed should exceed determined values.

Beaufort Wind Scale			
No.	Definition	Indicators	Speed (m/s)
0	Calm	Smoke rises vertically	0 - 0.2
1	Light air	Smoke drift wind direction	0.3 - 1.5
2	Light breeze	Wind felt on exposed skin. Leaves rustle; vanes begin to move	1.6 - 3
3	Gentle breeze	Leaves and small twigs constantly moving; light flags extended	3 - 5
4	Moderate breeze	Dust and loose paper raised. Small branches begin to move	5 - 8
5	Fresh breeze	Small trees in leaf begin to sway; glassy water, small waves form	8 - 11
6	Strong breeze	Large branches in motion. Whistling heard in electrical cables. Umbrella use becomes difficult	11 - 14
7	Strong wind	Whole trees in motion. Effort needed to walk against the wind	14 - 17
8	Fresh gale	Some twigs broken from trees. Cars veer on road	17 - 21
9	Strong gale	Slight damage to buildings (falling chimneys and tiles)	21 - 24



## 4.9 - Assessing the consistency of the work ground

The ground on which the vehicle can be positioned must be able to support the vehicle and its maximum bearing capacity.



### DANGER

#### Danger of tipping

The sinking of the vehicle base support may cause the vehicle tilting.



### ATTENTION

**Contact a qualified technician to assess the consistency of the ground according to the regulations in the country of use of the vehicle.**

Request in any case the advice of a qualified technician to know whether in the workplace, there are hidden cavities (pipes, wells, old tanks, basements, manure, etc...).



### NOTE

Refer to the chapter "*Technical data*" in the manual of the vehicle, to know the maximum load that each wheel or outrigger (if any) can apply on the ground while using the vehicle.



### DANGER

**When loading or unloading goods, the vehicle must always be in a horizontal position.**

Avoid loading or unloading operations if the vehicle is slanted.

## 4.10 - Moving safely



### NOTE

The following operations are standard for any type of installed equipment; however, refer to any warnings present in the equipment manual.



### WARNING

In the event of scarce visibility, have a person operate on the ground for signalling.



### WARNING

Do not lift or lower the loads when the vehicle is in motion.

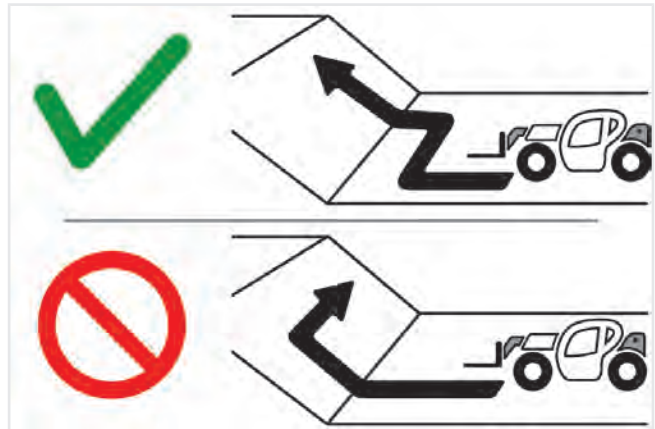

Figure: 150533-1

Operating on sloped terrain can cause overturning or sliding. Move forward and brake gradually and take all necessary cautions.

Always move in a straight line to go up or down a slope. Moving transversally or along the slope is extremely dangerous (fig. 150533-1).

Always use the parking brake when setting down or lifting a load on a slope.



### WARNING

**Check the vehicle is levelled before using the boom on sloped ground.**

Do not stop and leave the vehicle parked on a slope exceeding 15%, even with the parking brake engaged.

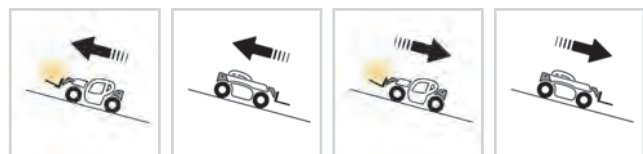

150534-1

150534-2

150534-3

150534-4

- In the event of having to travel uphill while transporting a load, operate always maintaining the load towards the top of the uphill (fig. 150534-1).
- When having to drive uphill without a load, operate with the vehicle facing downhill (fig. 150434-2).
- In the event of having to travel downhill while transporting a load, operate always maintaining the load towards the top of the uphill (fig. 150434-3).



- When having to drive downhill without a load, operate with the vehicle facing downhill (fig. 150534-4).

## 4.11 - General warnings for moving the load

Always adhere to safety regulations; always transport balanced, properly arranged load to prevent the risk of tipping.



### ATTENTION

**It is strictly prohibited to work without the respective load charts for the equipment and the vehicle.**

When using this vehicle, carefully follow the load charts of the vehicle with the equipment mounted at that moment.

Do not attempt to carry out operations which exceed the capacity of the assembled equipment or of the vehicle.

Do not modify the structure and vehicle stability in any way by trying to add counterweights, whichever artifact is used.

Always ensure the pallet, the boxes and other supports for the load are in good conditions and adequate to the load to be lifted; the sudden collapse of a rack of material is often caused by a faulty pallet.

**Do not move the load with boom lifted or extended.**

- Handle the vehicle with the boom raised only in exceptional circumstances. In these circumstances, operate with due prudence, reduce speed as much as possible and brake delicately. Make sure that visibility is always sufficient and ask an operator on the ground to guide you for the operations.
- Reduce the speed as much as possible and brake gently during handling operations.



### WARNING

Do not handle loads while the vehicle is moving.

Avoid passing over unstable objects. Remove dangerous, unstable objects instead of passing over or around them. Also avoid holes and ditches that might make the load jolt.

Before turning, slow down as much as possible, and monitor the load.

Do not change direction abruptly or at high speed.

Remember that hydraulic steering is very sensitive to steering wheel movements; steer gradually and avoid sudden movements.

Slow down before turning.

Pay attention to the side space, in particular if transporting wide loads. If possible, keep to the centre of the passage to avoid equipment or personnel from obstructing your path.



### WARNING

Handle loads with care, at low speed and without sudden or jolting movements, above all if they are carried at great heights.

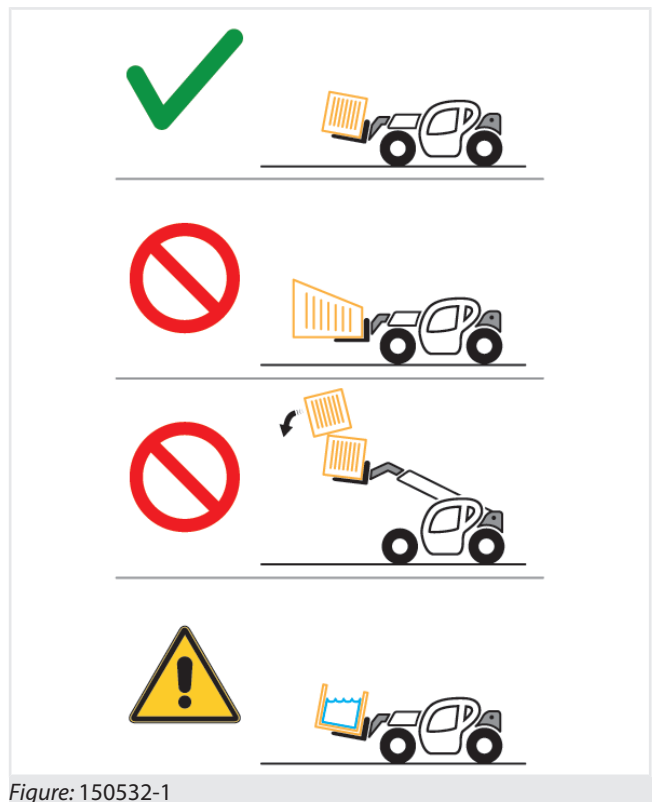

Figure: 150532-1

- Always ensure good visibility in the work area, including direct vision and visibility using wing mirrors in order to check for the presence of people, animals, obstacles, holes and changes in slope etc.
- Decrease the working speed of the vehicle in case of rain, fog, snow or in any case where visibility is reduced.
- If visibility on the right side is limited during boom operation, before lifting the load, ensure that the work area is clear and make note of the position of any possible obstacles and irregularities in the terrain.

- Always make sure there is good visibility (clean windows, clean mirrors, clean lights that work properly, etc.).
- Maintain control of the vehicle and its speed in all circumstances. The speed of the loaded vehicle must never exceed 10.0 Km/h (6.21 mph). If the load exceeds the maximum allowed load by 50%, vehicle speed must be reduced to 5.0 Km/h (3.11 mph).
- Do not drive in reverse for long distances.
- Brake gradually; avoid braking abruptly.
- Always maintain the safe distance from other vehicles in order to have sufficient space to brake in every condition.



### ATTENTION

Before lifting loads, operators must be familiar with the weight of the load and its centre of gravity.

- Transport the load as close as possible to the ground. Keep the load low, at a height from the ground of 300 mm. Never move with the load lifted more than necessary.
- The load charts are valid for centres of gravity of standard loads. For particular loads, contact your dealer.
- Pay the utmost attention during transport of loads with variable centre of gravity (e.g. Liquids). Operate with caution in order to limit such variations and to prevent the risk of vehicle overturning.
- Always ensure the moved load is correctly balanced and cannot fall on the ground. The loss of the load or part of it can entail a danger of damage to things and persons
- Pay the utmost attention to objects that may fall. Ensure there are no unstable objects on the upper part of the load.



### WARNING

**Never lift a load when the vehicle is on a sloped surface. When on a sloped surface, pay attention to the conditions of the ground. When working with the vehicle on a sloped surface with the load high, a jolt or a hole is sufficient to make the vehicle overturn.**

Do not move the boom if the vehicle is located on terrain with a slope greater than 2° (3.5%).

## 4.12 - Use of cables, ropes and slings



### DANGER

**It is strictly forbidden to lift or move any load by fastening ropes or chains only to the vehicle's attachment holding plate, to forks or to any other equipment not designed for this purpose.**

Various equipment set-up for lifting, provided with suitable hooks for the use of cables, chains and slings are available. For further information contact your Dieci dealer.

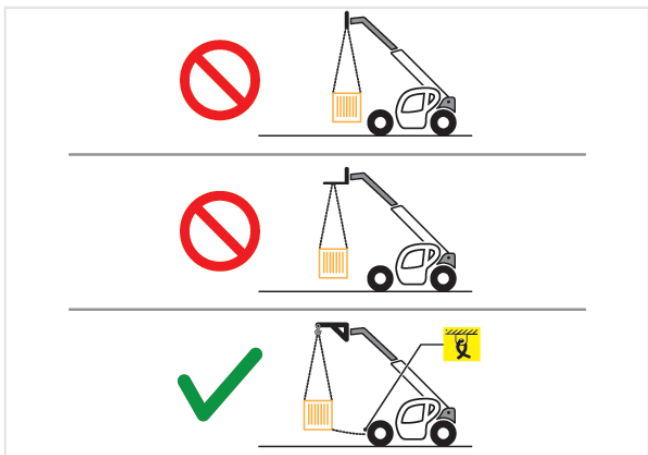

Figure: 150535-1

To keep the suspended load from swaying while being handled, the load can be fixed to the anchoring eyebolts of the vehicle while being transported.

## 4.13 - Road travel

### 4.13.1 - Road travel warnings



### ATTENTION

Before starting the road travel make sure to observe the relevant laws and regulations in the country of use.

The road travel requirements are shown on the Vehicle Registration Document.

Low beam lights must be on even during the day and in streets where there is no obligation to use visual and lighting signalling devices.

Ensure correct operation and cleaning of headlights, direction lights and windscreen wipers.



**WARNING**

**Check the correct position of the wing mirrors.**

The objects seen through the wing mirror are closer than they appear.

When driving on the road and/or on a slope it is necessary to be very careful to the engine rpm. A high number of rpm can lead to mechanical failures. Keep under control the engine rpm and speed.

Pay particular attention to loading docks, trenches, scaffolding and land recently excavated or filled.



**ATTENTION**

**When driving downhill on icy or slippery grounds, engage the slow mechanical gear (turtle).**

- In some countries it is mandatory to place wheel chocks under the tyres when the vehicle is stopped.
- Make sure that your vehicle is in compliance with local legislation in reference to the presence of the license plate when travelling on the road both at day and at night.



**WARNING**

Road transfer with equipment assembled to the fork holding plate is not allowed except those accepted by the legal authority of the country where the vehicle operates.



**WARNING**

**It is not allowed to travel on public roads with loaded vehicle.**

Comply with the maximum permissible mass written on the vehicle registration document.

**4.13.2 - Road travel instructions**

- Level the vehicle so that the wheel axles are aligned with the chassis (if present).
- Ensure that all outriggers have been perfectly retracted and raised (if present).
- Close the telescopic boom completely.
- Lower the telescopic boom completely and then raise it slightly to about 20-30 cm from the ground.
- Check the correct operation of the lights before moving on roads. Check that the rotating light for slow vehicle signalling is installed and running; keep the rotating light in operation both at day and at night.
- Perform the wheels alignment, so that they are perfectly aligned with the vehicle chassis.
- **It is mandatory** to arrange the steering as reported in the Vehicle Registration Document and lock the selector lever with the dedicated device.
- Make sure that the amount of fuel is sufficient.
- Assemble all the accessories required for road circulation depending on the country in which the vehicle is operating.
- Install an overhanging load signal panel on the boom head before the entering onto the road.
- Always evaluate the road to be travelled, taking account of suspended structures (e.g. bridges, underpasses, etc.) that could be damaged by the vehicle.

**4.14 - Momentary stop**



**ATTENTION**

If it is necessary to leave the driving position, follow the steps in the "Parking the vehicle" paragraph.



**WARNING**

Never move away from the vehicle, leaving the engine running or the ignition key on the vehicle.



**WARNING**

Do not stop and leave the vehicle parked on a slope exceeding 15%, even with the parking brake engaged.

- Gradually release the accelerator pedal.
- Stop the vehicle on even ground.
- Engage the parking brake
- Bring the movement selection lever to "N".
- During the running-in of the vehicle (50 h), do not keep the diesel engine at minimum revs for too long.

## 4.15 - Parking the vehicle

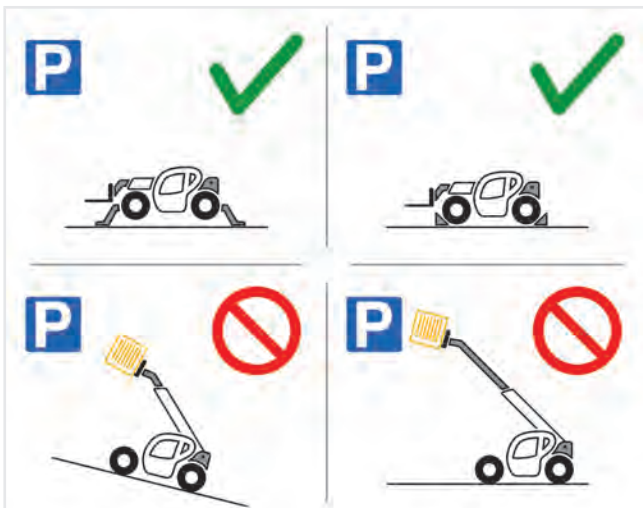

Figure: 150536-1

Never leave in any case the vehicle parked with a raised load.

- Always park on flat, firm and level ground, where there is no risk of falling rocks, landslides or flooding.
- Lower outriggers to the ground (if present).
- Retract the boom completely and lower it to the ground.
- Engage the parking brake
- Bring the movement selection lever to "N".
- Run the engine at idle speed for some seconds before turning it off, in order to allow the engine cooling.
- Turn the ignition key to the engine stop position.
- Remove the key from the ignition switch.
- Lock the hydraulic controls with the special devices (if present).
- Close the windows and lock them with the handles.
- Close the cab door by key.
- Place wedges under the wheels.
- Make sure that the vehicle is parked so as not to impede its movement and at least 5 meters away from the railroad tracks.



### WARNING

Do not stop and leave the vehicle parked on a slope exceeding 15%, even with the parking brake engaged.

## 4.16 - Starting and stopping the vehicle

### 4.16.1 - General warnings regarding starting up the vehicle



#### WARNING

Do not use the vehicle without having first read and understood all parts of this manual, and without having attended an adequate training course.

- Before starting the engine, make sure all control levers are in a neutral position, the parking brake is engaged, the engine hood is closed and that there is nobody in the area surrounding the machine.
- The machine can only be started up or maneuvered when the operator is seated in the driver's seat, with the seat belt fastened and adjusted.
- The machine may move suddenly if started up without following the correct procedure, thus, creating the risk of damage.
- Never start the engine by causing a short circuit between the terminals of the starter.
- Never start-up the engine by pushing or pulling the vehicle. This could seriously harm people or cause serious damage to the vehicle.
- Be careful when using auxiliary batteries as the gas contained in these may explode, causing serious damage. Follow the instructions provided in the "Emergency procedures" chapter, "Start-up using auxiliary batteries" paragraph to start the engine using auxiliary batteries. An incorrect procedure can cause serious damage to the electrical/electronic system, the vehicle could move suddenly, the battery could explode and damage could be caused to objects and/or people.
- Do not start the engine or touch the levers of the machine if a danger sticker or a maintenance in progress sign is placed inside the cab.

### 4.16.2 - Inspections prior to starting-up

#### 4.16.2.1 - Inspecting the machine

Carefully inspect your machine every day or before every shift.

Carry out the following inspections and operating checks:

- Parking brake efficiency
- Intact condition of the tires
- Type of tire suitable for the type of work ground
- Engine oil level (check and top-up, if necessary)
- Hydraulic oil level (check and top-up, if necessary)
- Air filter clogging indicator (check and clean, if necessary)
- Tire inflation and pressure (check)
- Fuel level (check)
- Signaling and warning devices (check)
- Steering efficiency
- Service brake efficiency
- Tightness of all nuts and bolts
- Lighting
- Direction indicators
- Emergency Lights
- Switches
- Indicator lights
- Windscreen wipers
- Reverse movement alarm
- Position and condition of rear view mirrors



## DANGER

**Immediately stop using the machine in case of malfunctions or if it does not comply with safety standards.**

Contact an authorized *Dieci s.r.l.* workshop if the machine shows malfunctions. Refer to the "Maintenance" chapter for information regarding routine maintenance.



## NOTE

A thorough inspection is required if the machine is not used for a prolonged period of time. A detailed description of the operations is provided in the "Machine storage" chapter

### 4.16.2.2 - Inspecting the work area

- Examine the work area when working at the edge of an excavation or on soft ground as the machine could overturn.

- Examine the conformation and condition of the terrain of the work area before beginning to operate.
- Keep the machine well away from the edge of the excavation and the side of the road.
- When working on a slope or near the roadside, have another person present for signaling.
- Pay utmost attention when working on icy ground. The ice will melt as the temperature rises and the ground will become slippery.
- Check for any overhead power lines or underground piping.
- Do not work in places at risk of landslides or falling rocks.
- Take due precautions to prevent any unauthorized persons from entering the working area.
- When moving through or operating in shallow water or soft ground, verify the shape and the conditions of the land, the water depth and flow rate before beginning the operation.

### 4.16.3 - Starting-up the engine

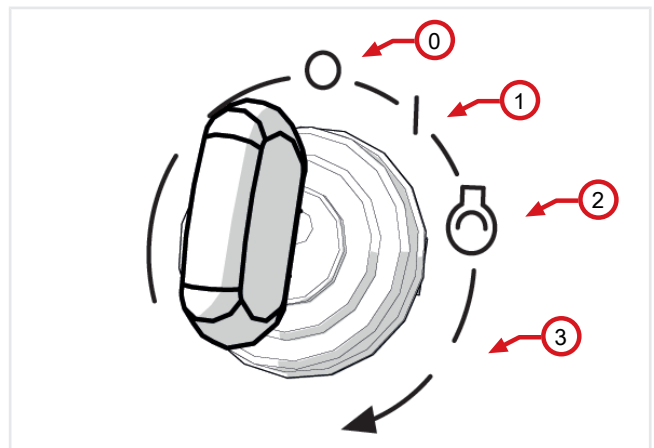

Figure: 150538-1

**Proceed as follows to start-up the engine of the vehicle:**

1. Press the parking brake switch.
2. Bring the movement selection lever to neutral.
3. Remain seated in the driver's seat.
4. Turn the ignition key (fig. 150538-1) clockwise to position "1".

With the key in this position:

- The control panel and instrument panel will be powered
- A buzzer will sound, indicating that the key has been inserted. This buzzer also serves to warn any persons in the surrounding area that the vehicle has been started up.



- A check-up of the instrumentation will be performed with all the indicators lighting up for about 5 seconds. Only the following lights must remain switched on at the end of the check-up:
  - Engine oil pressure warning light
  - Battery charge indicator light
  - General alarm warning light
  - Intermittent buzzer
  - Other indicators of activated functions (e.g.: Parking brake, gears engaged, etc.)

**WARNING! If other indicators remain on signalling malfunctions or if one of the previous conditions does not occur, do NOT start-up the engine and refer to the "Maintenance" chapter or contact the Dieci service centre.**

- Turn the ignition key (fig. 150538-1) to position "3" to start-up the engine. Release the starter within 5 seconds.
- Release the key once the engine has started. The indicators related to the engine oil pressure and battery charge must go off once the engine is started up.
- If the engine does not start within 5 seconds, try again at regular 15 second intervals to prevent overloading the starter motor.

#### 4.16.4 - Warm-up after starting-up

During the first few minutes of use, keep the speed slow in order to warm up the engine and hydraulic oil.



#### WARNING

**Serious damage can be caused to the engine and the hydraulic system if the engine reaches high rpm before the operating oil temperature and pressure levels are reached.**

Let the engine run at 1100 - 1300 rpm for about 5 minutes so as to bring the engine oil to the operating temperature, particularly, with outdoor temperatures below 0 °C.

#### 4.16.5 - Start-up at low environmental temperatures

Consider the following warnings before starting-up at low environmental temperatures and with a cold engine:

- In order to prevent discharging the battery, do not prolong each attempt to start-up by more than 15 seconds; however, if the engine does not seem to be starting-up, extend the time to a maximum of 30 seconds.
- Wait at least one minute before trying to start-up again.
- It is recommended to not exceed six start-up attempts so as not to discharge the battery excessively.



#### NOTE

It is recommended to use anti-freeze diesel at environmental temperatures lower than 0°C, so as to make sure the engine is optimally supplied, without reducing performance.

#### 4.16.6 - Causes of failed start-ups

Check the following if the engine does not start-up:

- The parking brake switch is pressed.
- The gear selection lever is in the neutral position.
- No emergency buttons are pressed.

After checking all the previous conditions, remove the cause of failure to start and try the starting procedure again.



#### NOTE

If the problem persists, contact a *Dieci* after-sales center.

#### 4.16.7 - Turn off the vehicle

It is recommended to perform the following before switching the engine off:

1. Bring all the control levers to the idle position.
2. Bring the engine to low speed for a few seconds.
3. Turn the ignition key to position "0".



**NOTE**

**The images used to describe components and controls refer to a complete vehicle with all accessories; these may vary depending on the attachments and on the configuration chosen.**

Refer to the “Definitions” manual to understand references such as: Right side, Left side, Front and Back used in the manual.

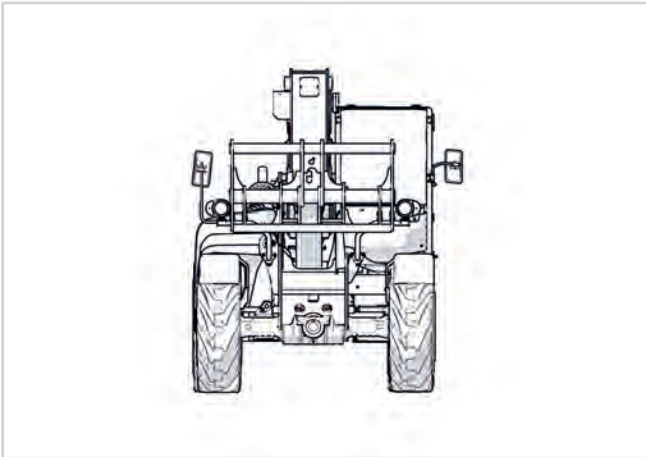

150641-1: Front view

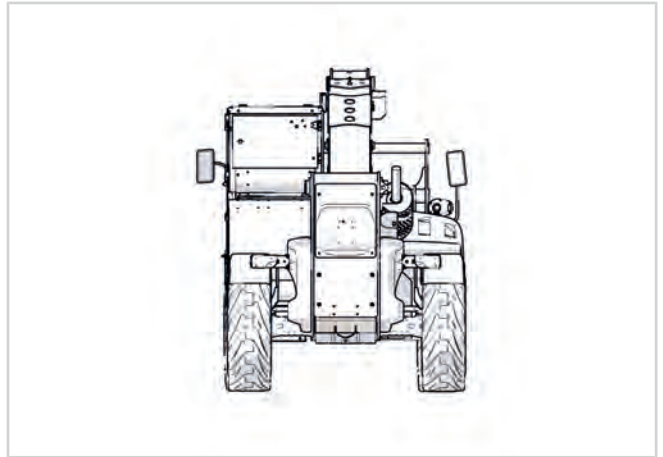

150641-2: Rear view

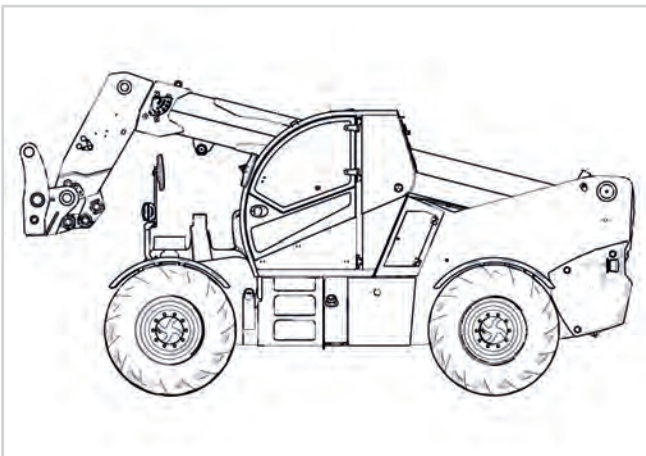

150641-3: Left view

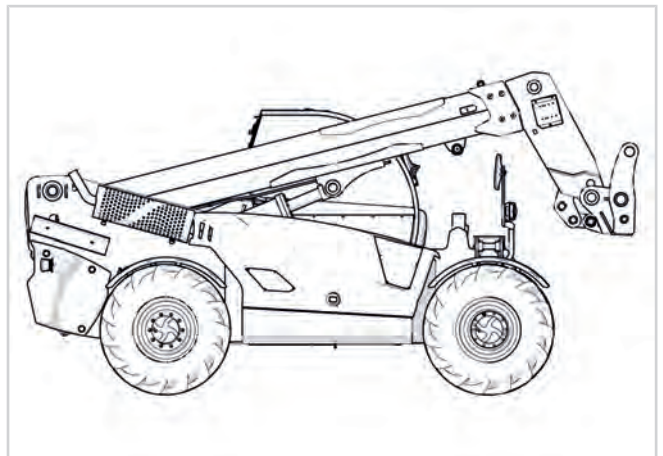

150641-4: Right view

## 5.1 - Left side components description

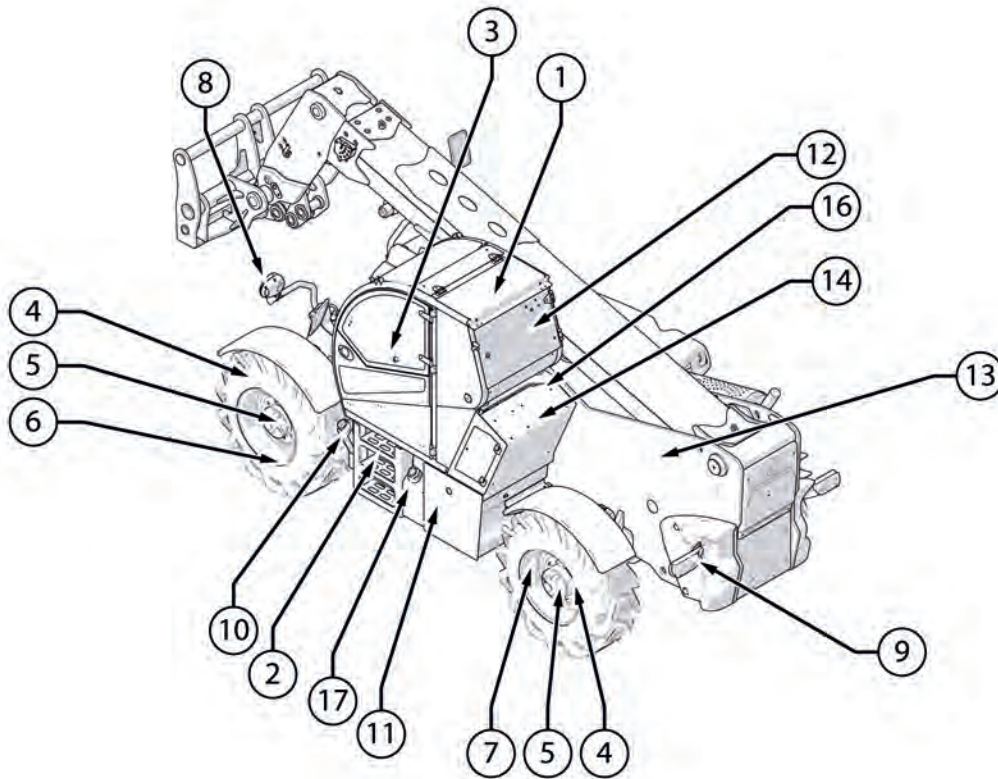

Figure: 150970-1: Left side vehicle description

1 Cab	2 Steps for climbing on
3 Door	4 Wheel
5 Epicycloidal reduction gear	6 Front axle
7 Rear axle	8 Left front headlight
9 Left rear headlight	10 Fuel tank
11 Oil tank	12 Rear emergency exit
13 Radio remote control receiver (optional)	14 Battery
15 Battery compartment	16 Air conditioned (optional)
17 Not present	



**5.2 - Right side components description**

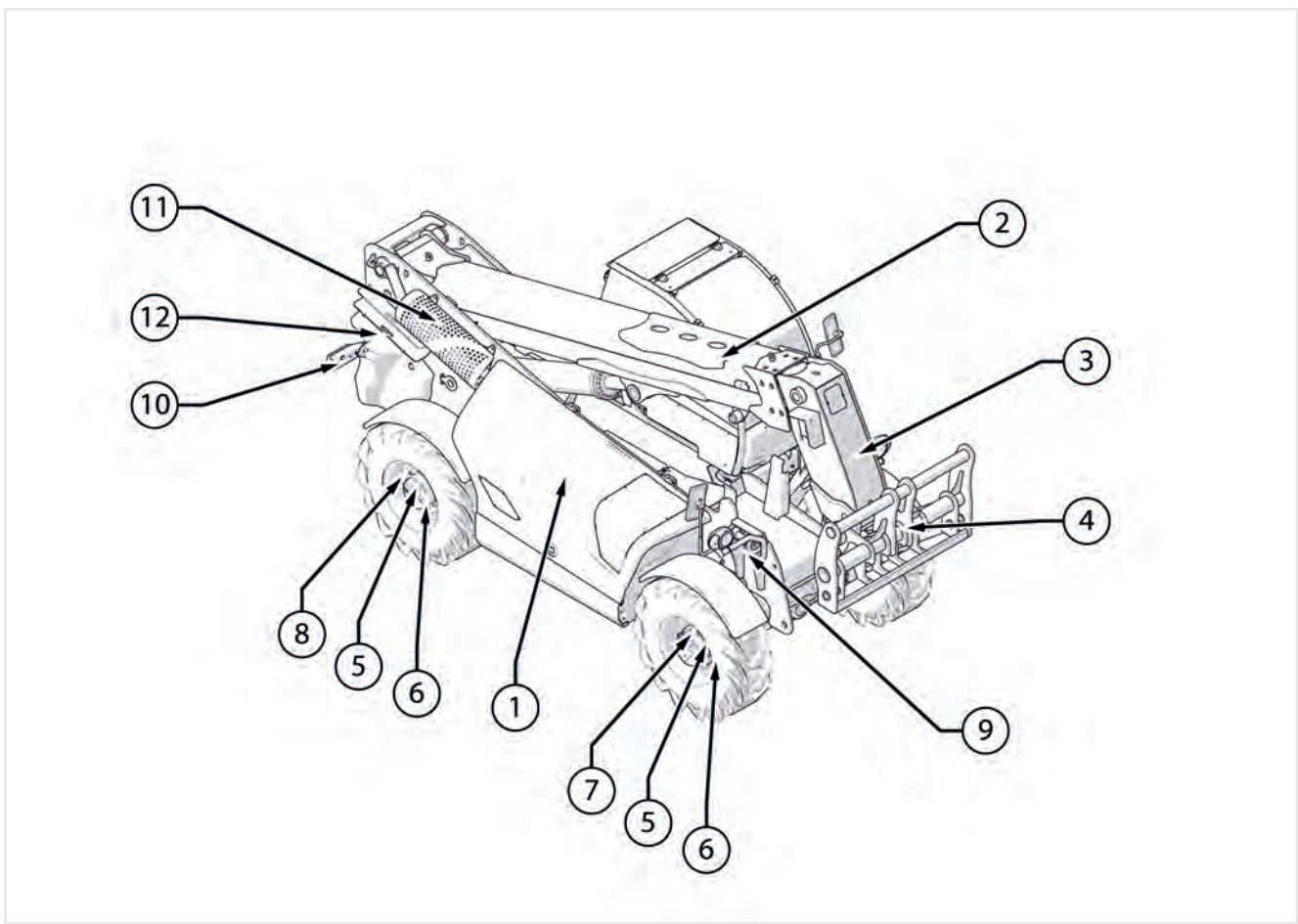

Figure: 150971-1: Right side vehicle description

1 Engine hood	2 Telescopic boom
3 Boom head	4 Attachment holding plate
5 Wheel	6 Epicycloidal reduction gear
7 Front axle	8 Rear axle
9 Right front headlight	10 Right rear headlight
11 Muffler	12 Boom support rod

### 5.3 - Engine components description

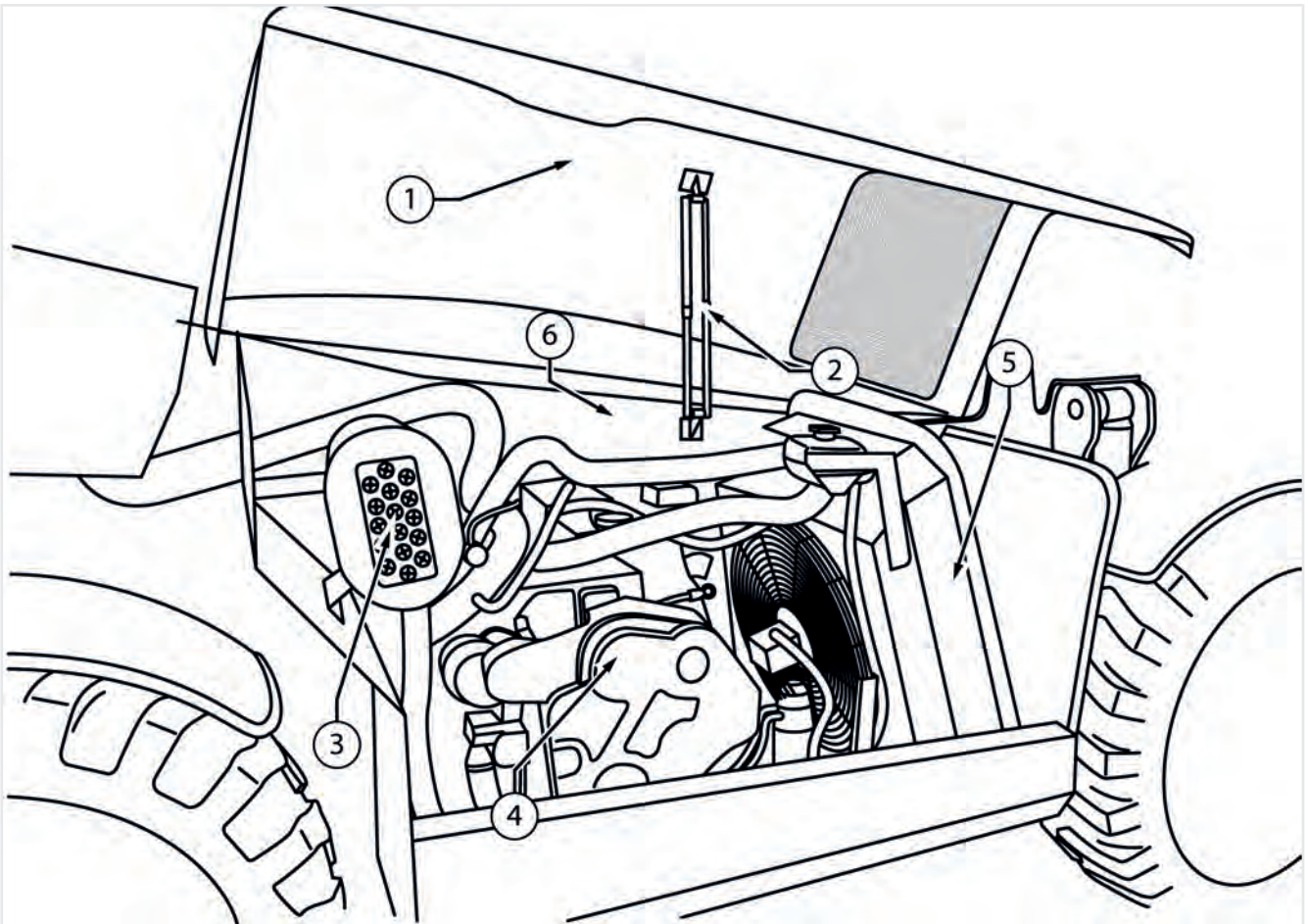

Figure: 150973-1: Engine description

1 Engine hood

3 Air filter

5 Radiator

2 Safety rod

4 Engine

6 Engine control unit

**5.4 - Cab components description**

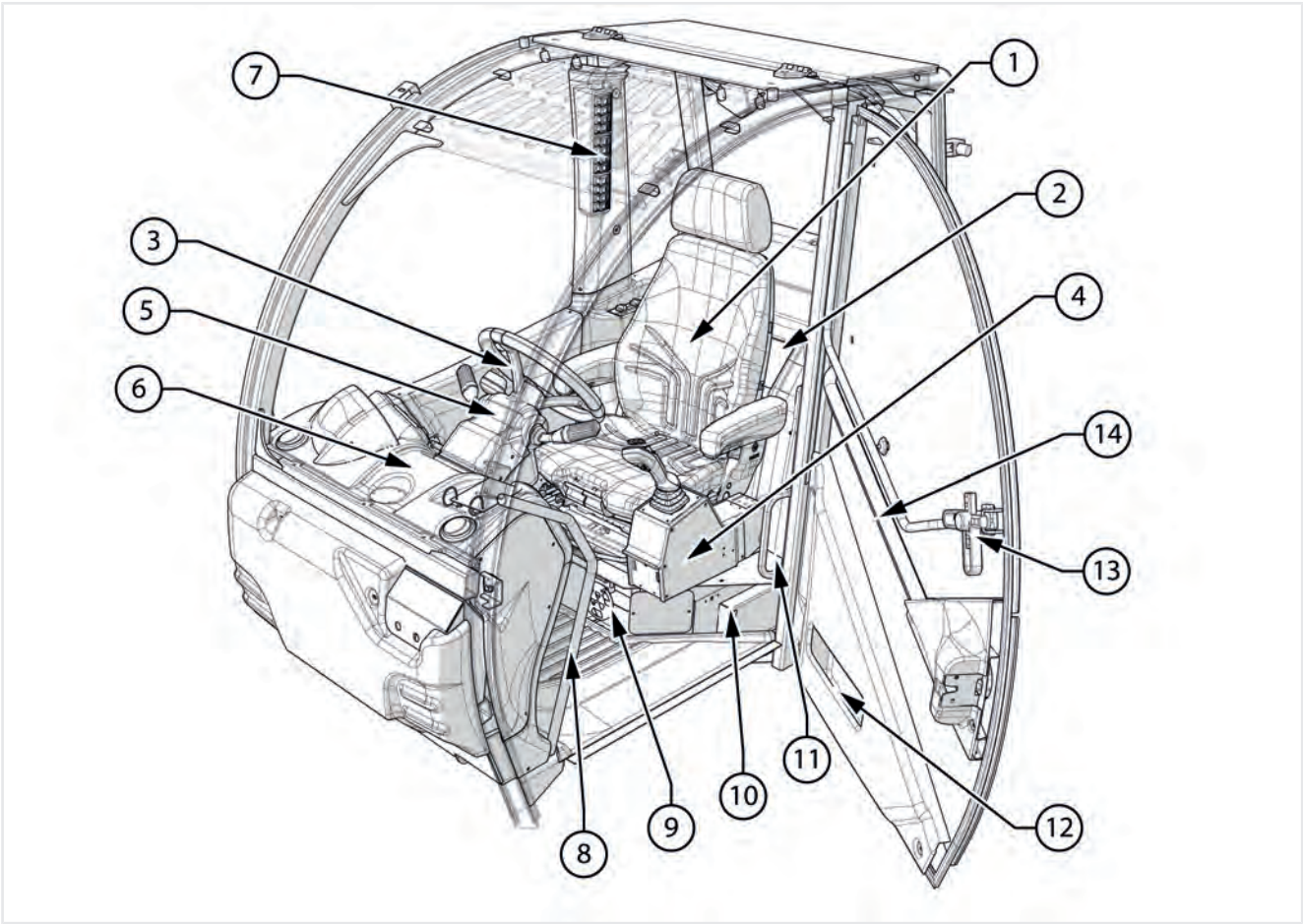

Figure: 161044-1: Cab description

1 Seat	2 Storage compartment
3 Right joystick	4 Not present
5 Steering wheel	6 Central instrument panel
7 High instrument panel	8 Handle for climbing on
9 Cab ventilation adjustment	10 Cab air filter
11 Handle for climbing on	12 Storage compartment
13 Glass opening handle	14 Internal door opening handle

## 6.1 - List of safety devices

Safety devices	Additional information	
Safety devices	7.1	Cab
	7.1.1	ROPS - FOPS Cab
	7.1.17	Emergency Lights
	7.1.18.1	Deadman seat sensor
	7.1.18.3	Seat belts
	7.1.19	Emergency stop
	7.1.21	Emergency exit: Rear glass
	7.3.14	Anti-tipping device
	7.3.14.1	Anti-tipping device description
	7.10	Safety rod
	7.11	Wheel wedge
	7.12	Block valves
	7.13.1	Load Charts

## 6.2 - Safety stickers

### 6.2.1 - Warnings for safety stickers

Some safety stickers have been applied on the vehicle and equipment in the positions shown below. Their purpose is to provide a guide for your own and others safety. Before starting to work, check the content and location of the stickers indicated on this manual. Review the safety stickers with all operators who will use the vehicle and equipment.



#### ATTENTION

**Make sure to have fully understood their correct location and their contents.**

To ensure proper interpretation verify that they are in the correct position and that they are always kept clean.



#### DANGER

**Clean them when they are covered by mud, concrete or debris.**

It is absolutely forbidden to clean the stickers using solvents or gasoline; the labels may become discoloured.

See the summary table in the "Maintenance" chapter for the for safety stickers maintenance and control deadlines.

Replace the safety stickers in case of deterioration, damage or loss, as these must always be read and interpreted correctly.



#### WARNING

Do not under any circumstances remove the safety stickers.



#### NOTE

The purchase order of replacement safety stickers must be made in the same way in which any spare part is ordered (be sure to communicate the model and serial number of the vehicle or equipment when placing the order).





## 6.2.2 - Meaning of safety stickers

SIGNAL	CODE	DESCRIPTION
	AXA1428	Indicates the tire pressure
	AXA1807	Indicates the maximum guaranteed acoustic power
	AXA2209	Outriggers maximum load on the ground (R.max daN=) 10000
	AXA2227	Tires maximum load on the ground (R.max daN=) 10000
SIGNAL	CODE	DESCRIPTION
	AXA1163	Warning, keep the boom fully retracted when digging with buckets.
	DOCAD0000053	Danger, stop the engine and remove the ignition key during maintenance operations
	DOCAD0000054	Danger, comply with the safety distances from electric lines
	DOCAD0000370	Indicates where to refuel
	DOCAD0000371	Indicates the type of fuel to be used
	AXA1431	Indicates the lifting points
	AXA1432	Indicates the points at which to anchor the vehicle for transport or towing
	DOCAD0000090	Position of the hitch for vehicle towing.
	AXA1433	Indicates where to check the hydraulic oil level

SIGNAL	CODE	DESCRIPTION
	AXA1434	Indicates where refueling hydraulic oil
	AXA1435	Danger, moving mechanical parts, do not remove the safety guards and wait that the parts have stopped before carrying out any maintenance
	AXA1436	Indicates the position of the safety rod for lifting cylinders
	AXA1438	Indicates vehicle parts that can not be walked on
	AXA1439	Danger moving mechanical parts
	AXA1440	Danger of hot steam under pressure escaping
	AXA1441	Danger of hot surface
	AXA1492	Indicates the position of the brakes oil tank and the type of oil to use
	AXA1493	Warning, keep a safe distance
	AXA1498	Indicates the position and instructions for using the battery isolation switch
	DOCAD0000063	Battery isolation switch button instructions
	AXA1501	Indicates lubrication points
	AXA1506	Compulsory use of seat belts
	AXA1514	Emergency exit
	AXA1515	Remove the cotter pin
	AXA1773	Warning, do not reach high speeds or over-revving the engine in downhill
	AXA2089	Caution, hydraulic circuit with pressure accumulators

SIGNAL	CODE	DESCRIPTION
	AXA2103	Warning, keep a safe distance
	AXA2430	Do not stand under the forks or transport people with the forks
	AXA2609	Instructions for joystick with capacitive deadman switch and continuous oil function
	AXA2610	Instructions for joystick with capacitive deadman switch and continuous oil function and FNR function
	AXA2613	Instructions for joystick with standard mechanical deadman button
	AXA2614	Instructions for joystick with mechanical deadman button and continuous oil function
	AXA2751	Instructions for joystick with mechanical deadman button and continuous oil function and FNR function
	AXA1803	Instructions for joystick for standard man basket
	AXA2633	Instructions for joystick for man basket with continuous oil function
	AXA2708	Type of oil used in the hydraulic system
	AXA2798	Type of oil used in the hydraulic system ISO 32
	AXA1892	Indicates maximum use of the vehicle in case of wind
	AXA1497 ***	Hand throttle use indication
	AXA1437	Engine hood opening lever indication
	AXA1446	Horizontal boom indication
	AXA2748	Battery maintenance danger
	AXA2042	Steering mode for construction vehicle

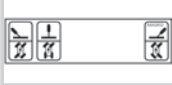

SIGNAL	CODE	DESCRIPTION
	AXA2652 **	Steering mode for tractor vehicle
	AXA1444 *	Danger of feet crushing

\* Stickers present in case of outriggers

\*\*\* Stickers for mechanical engines

### 6.2.3 - Safety stickers position on the vehicle

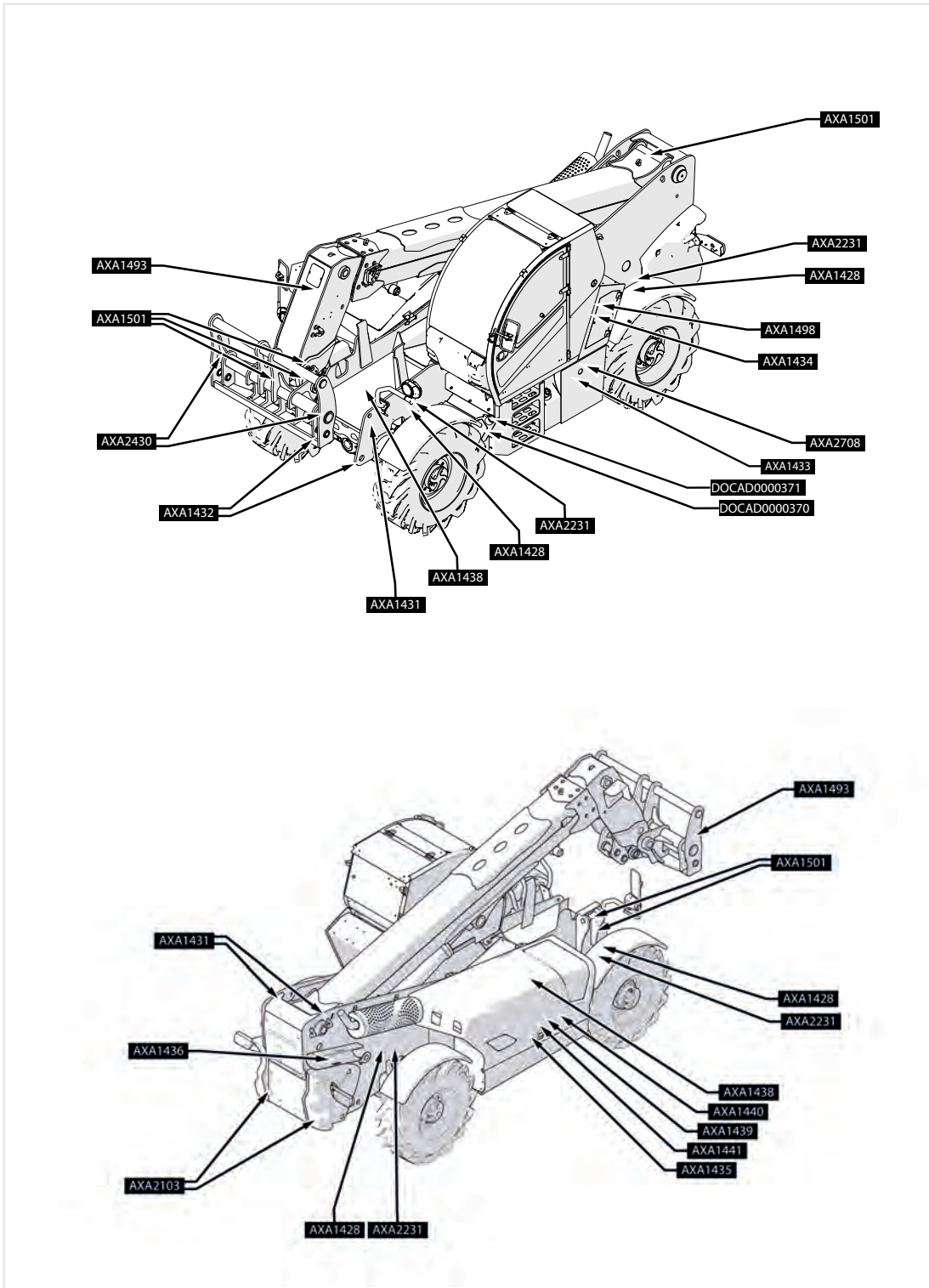

### 6.2.4 - Safety stickers position in the cab

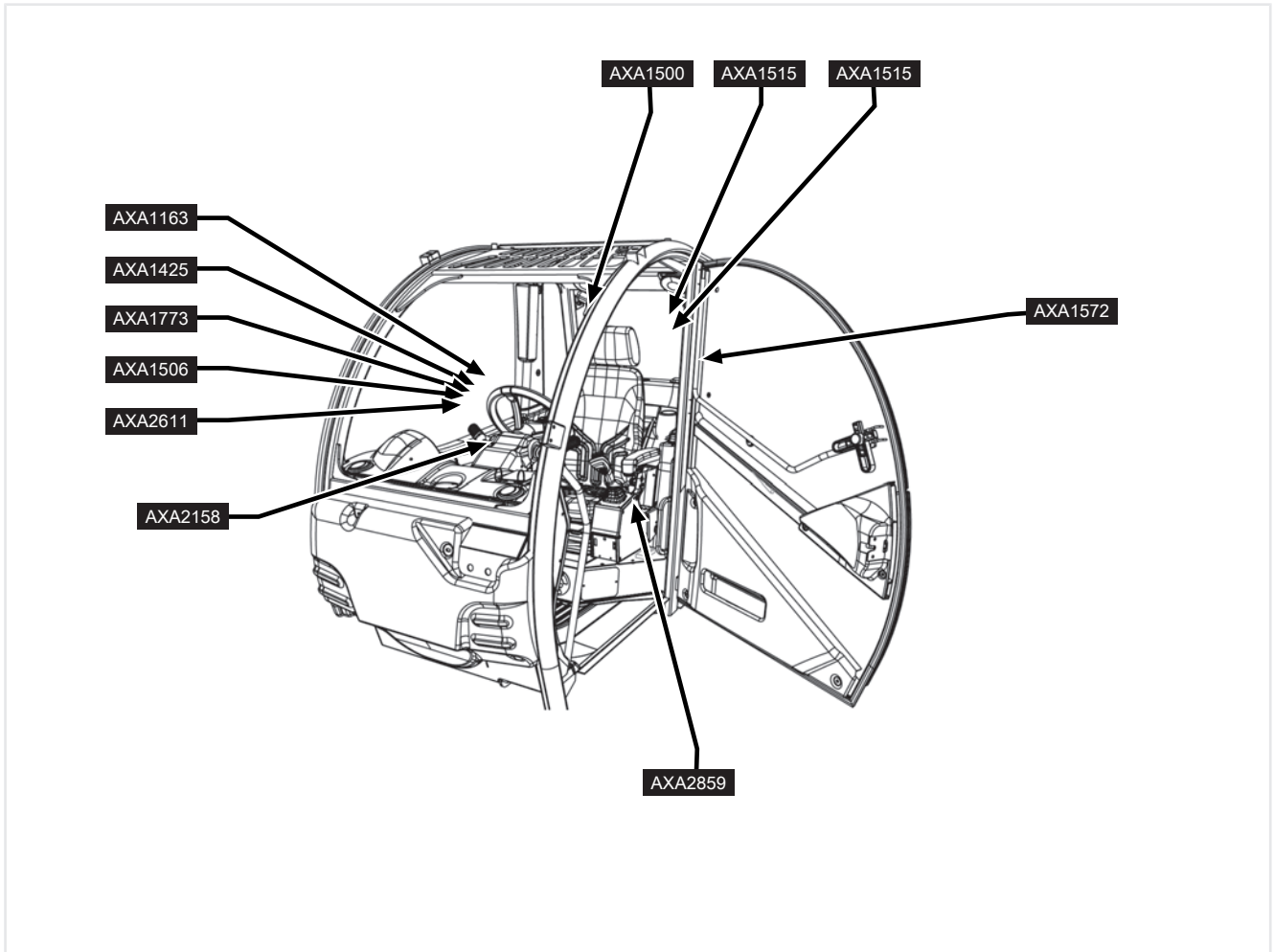

## 7.1 - Cab

### 7.1.1 - ROPS - FOPS Cab

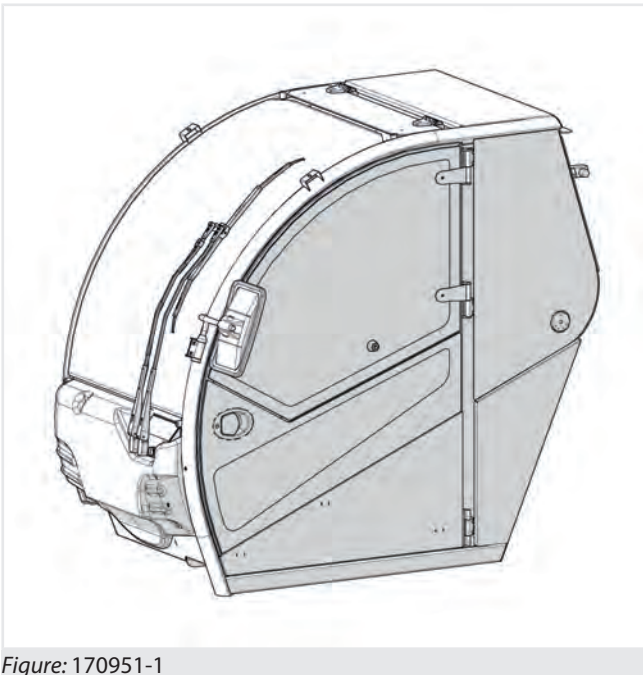

Figure: 170951-1

The vehicle is equipped with an approved cab:

- **ROPS** (Roll Over Protection Structure)
- **ISO 3471**
- **FOPS** (Falling Objects Protective Structure)
- **ISO 3449**

The operator is therefore protected in the event of vehicle tipping and in the event of falling objects, as prescribed for earth moving vehicles.



### ATTENTION

The cab is a safety device and as such must be always kept in the right conditions of use.

In case of cab tampering, the manufacturer has no civil liability in case of an accident, therefore it is absolutely forbidden to:

- Change, drill, or alter in any way the structure of the cab.
- Weld or mechanically connect parts to the cab chassis.
- If the fastening bolts are replaced, use elements of different strength class.
- Connect chains or ropes to the cab for the purpose of towing.



### WARNING



**In the case of vehicle tipping, staying in the cab with fastened seat belts allows to obtain a better protection.**

If the cab has undergone visual damage it must be replaced by consulting the authorized service center or Dieci authorized workshop.

The cab is classified as: CATEGORY "1"

The cab approved as category "1" does not offer full protection against the ingress of dust, aerosols and vapors. Consult and follow the instructions provided by the manufacturer of the chemicals used (such as pesticides, fungicides, herbicides, etc..) and those supplied by the manufacturer of the sprayer. Use the appropriate personal protective equipment and clothing (PPE) when indicated in these instructions, even when you are inside the cab.



### DANGER



**Inhalation danger for operators and bystanders.**

For protection against harmful dust, aerosols and vapors, refer to the instructions provided by the manufacturer of chemicals, by the manufacturer of the sprayer and to the basic rules contained in this manual.

Refer to the packaging of the product used to use the appropriate protective equipment.

**7.1.2 - Door opening**

**7.1.2.1 - External door handle**

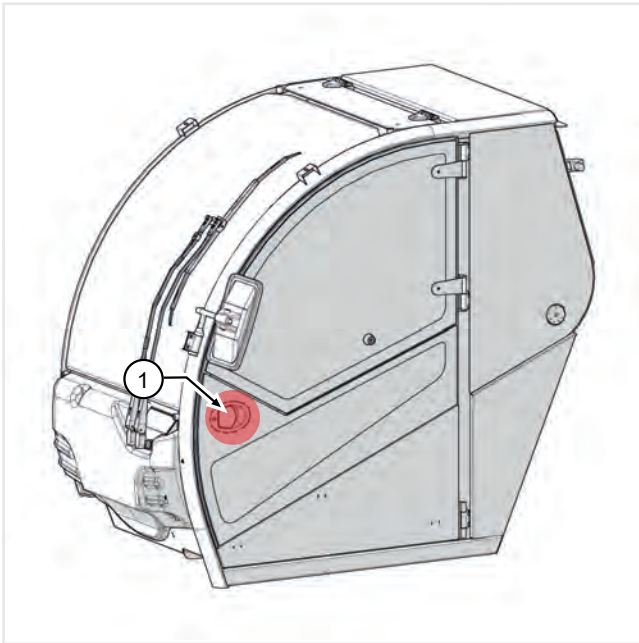

Figure: 150901-1

The door of the cab is equipped with an external handle "1" (fig. 150901-1) with lock.

To open the door from the outside:

- Insert the key into the lock and turn it clockwise/anti-clockwise to engage/disengage the lock.
- Pull the handle towards yourself to release the door with lock disengaged.



**NOTE**

With lock engaged, the door will not open by the handle.



**WARNING**

It is absolutely forbidden to operate with the cab door open.

**7.1.2.2 - Internal door handle**

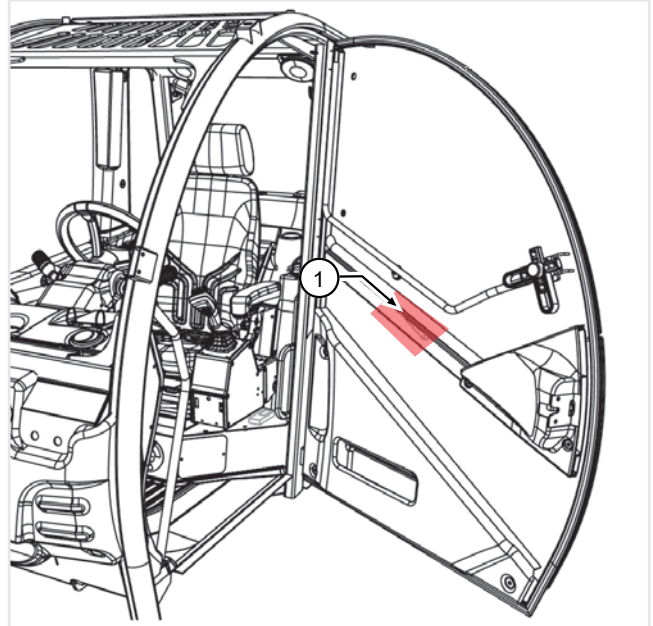

Figure: 150901-2

To open the door from the inside (fig. 150901-2):

- Press the button on the handle to release the door "1".
- Push the door to the outside to complete the opening.
- Accompany the door with one hand while opening it.



**ATTENTION**

Before pushing the door outwards verify that the opening area is free from obstacles of various kinds.

**7.1.3 - Climbing in/out**



**NOTE**

Before climbing into the cab, make sure your hands and your shoes are clean and dry to avoid slipping and falling.

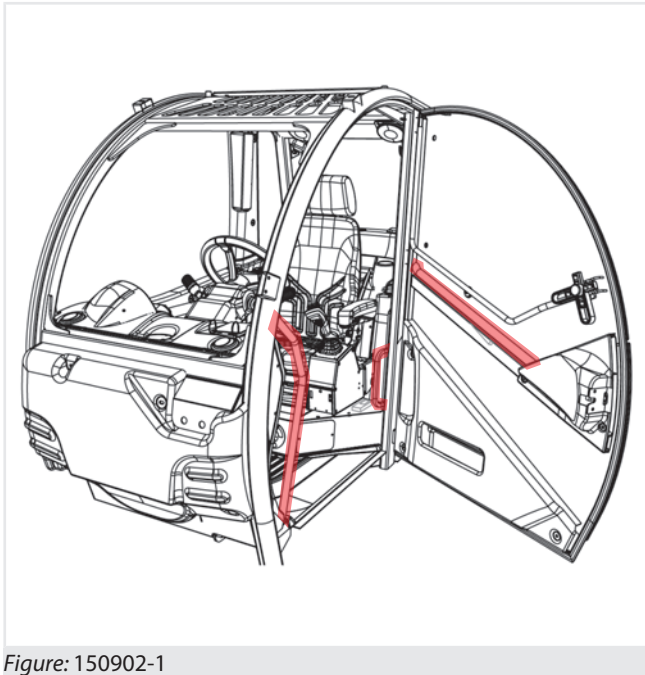

Figure: 150902-1

Use only the appropriate handles and steps to access the cab, do not use the controls and the steering wheel from inside. Climb in and out of the vehicle always turned towards the driver's cab.



## WARNING

### DANGER

Climbing in and out of the cab is allowed only when the vehicle is stopped with the parking brake engaged. Do not leave the cab with the vehicle in motion.

## 7.1.4 - Door glass

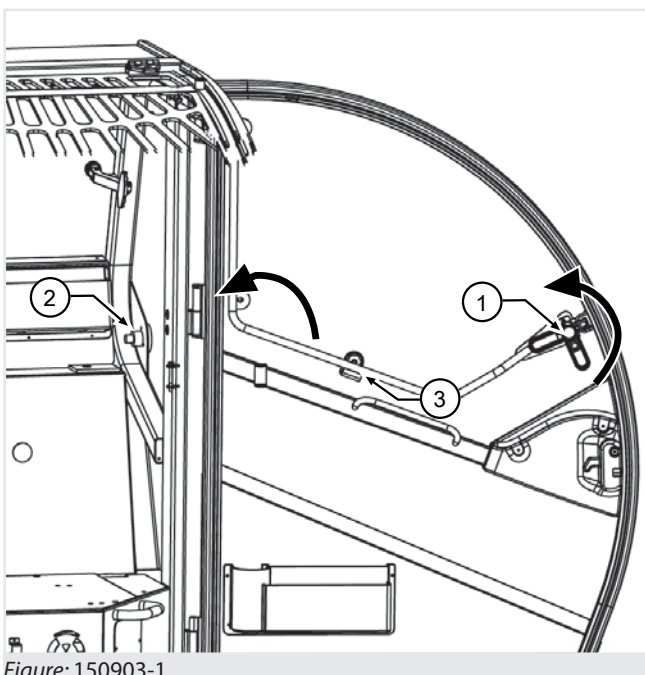

Figure: 150903-1

To open the door glass (fig. 150903-1):

- Lower the grip "1" turning it anti-clockwise and pushing the glass outward.
- To stop the glass in the open position push the bolt of the glass "2" inside the fastener "3" pressing slightly.

To close the door glass it is necessary to:

- Press the button inside the pin "3" to unlock the glass and be able to close it.
- To close the glass pull it towards yourself to the starting position.
- Rotate the grip "1" in clockwise direction to lock the glass in the closed position.



## ATTENTION

**Before opening or closing the glass make sure that the surrounding area is free from obstacles of various kinds.**

Before starting to working make sure that the glass of the door is locked, whether it is in the open or closed position.

## 7.1.5 - Heated mirrors \*



## NOTE

Heated mirrors are optional attachments.

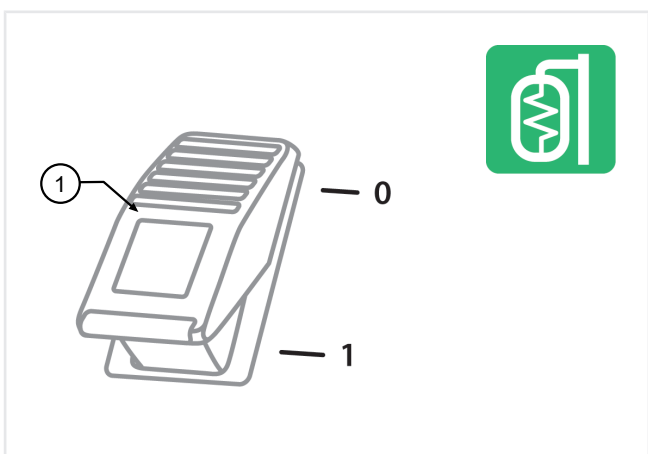

Figure: 160763-1

To start the heated mirrors function press the switch "1" (fig. 160763-1).

The illuminated warning light on the switch indicates that the heated mirrors function is on.



**7.1.6 - Rear glass**

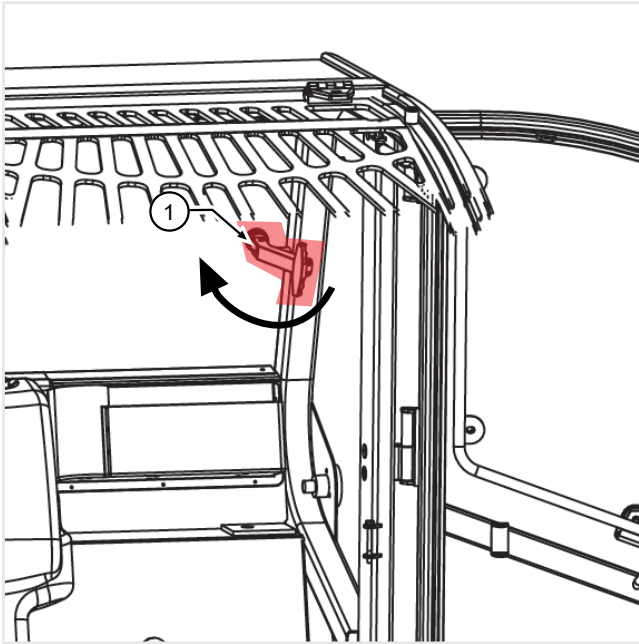

Figure: 150904-1

To open the rear glass, lift the handle "1" (fig. 150904-1) and push the glass outward.

The glass is maintained in the open position by the handle.

To close the rear glass, pull the handle back in the cab and lower until it until the whole unit is completely locked.



**WARNING**

**Danger of crushing**

In case the handle would no longer maintain the open position of the glass, replace it in the shortest possible time.



**NOTE**

The rear glass also serves as an emergency exit, see the "Safety Devices" chapter for more information.

**7.1.7 - Canopy**

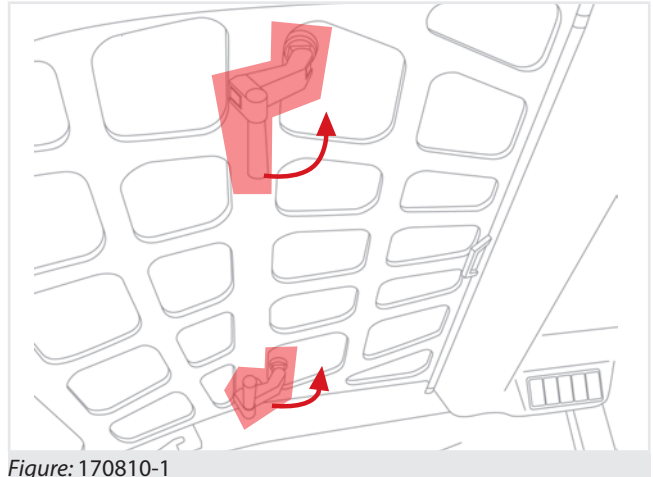

Figure: 170810-1

To open the canopy, hold the handle and push upward with a rotating motion. The position is held by the handles fully extended.

To close proceed with the inverse operation until the handles are locked.



**WARNING**

**Danger of crushing**

In case the handles would no longer maintain the open position of the glass, replace them in the shortest possible time.

**7.1.8 - Sunshade**

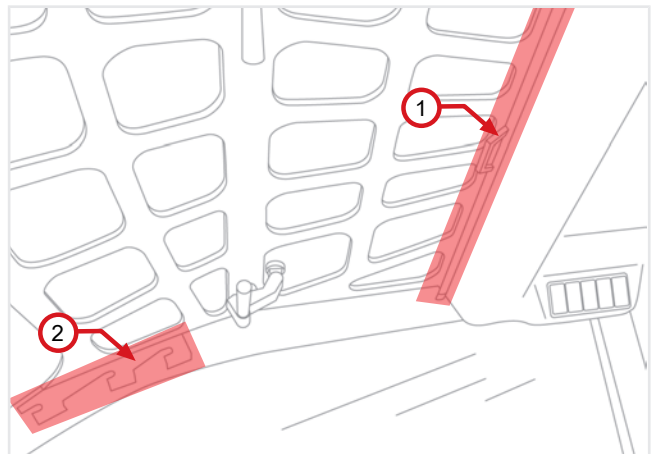

Figure: 170811-1

The Sunshade is located at the top of the cab.

To lower the Sunshade, take the handle located at the centre of "1" and lower it down to lock it with the hooks provided "2".

To close the sunshade, lower the handle "1" to release it from the hooks "2" and take back the sunshade in closure.

### 7.1.9 - Cab ventilation

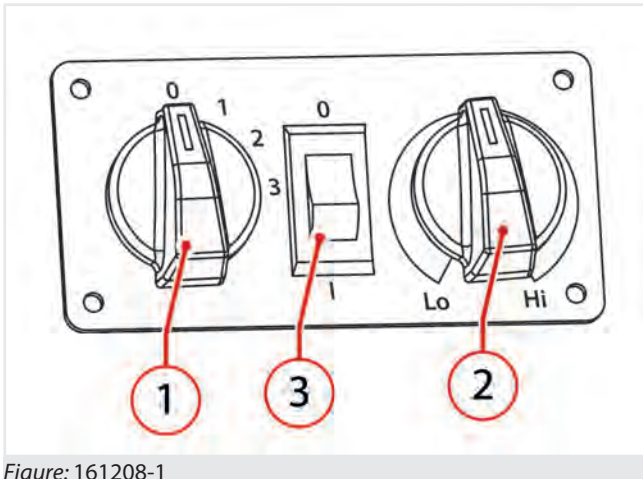

Figure: 161208-1

#### 7.1.9.1 - Ventilation adjustment

To adjust the ventilation turn the knob "1" (fig. 161208-1).

Clicks indicate respectively:

- 0 - Off
- 1 - First speed
- 2 - Second speed
- 3 - Third speed

#### 7.1.9.2 - Air temperature adjustment

To adjust the temperature of the air coming out of the vents, turn the knob "2" (fig. 161208-1):

- Turning the knob clockwise (in the red scale) the temperature increases.
- Turning the knob counterclockwise (in the blue scale) the temperature decreases until it is next to the outside temperature.

### 7.1.9.3 - Air vents

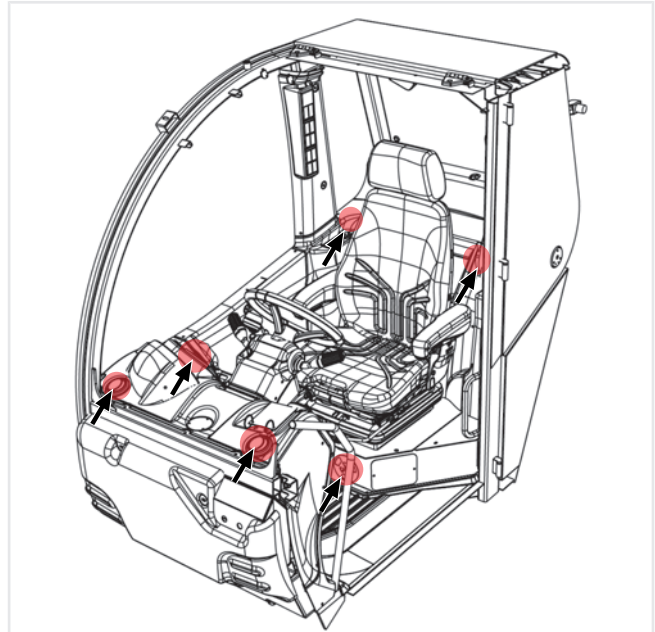

Figure: 150905-1

To open the air vents press on one side of these and adjust the air flow direction using the fins or rotating the vent.

To close the vents push the fins bringing them to the horizontal closing position.

### 7.1.9.4 - Air recirculation inside the cab

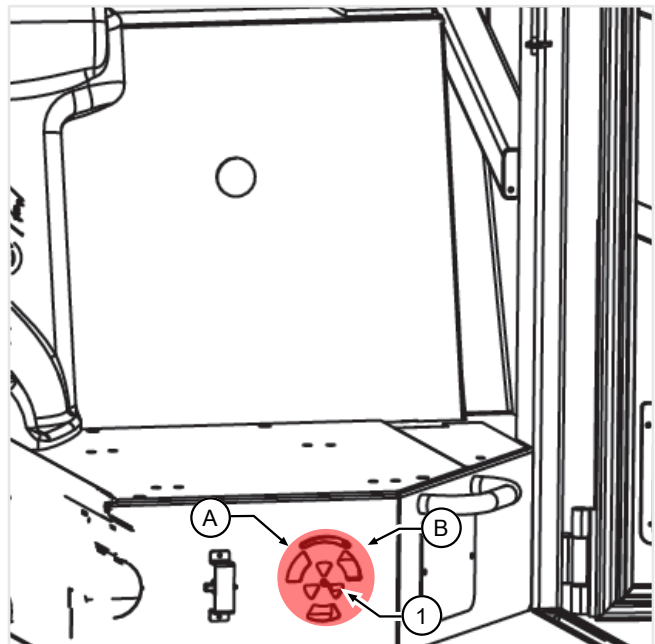

Figure: 170950-1

To enable or deactivate the air circulation in the cab use the lever "1":

- In "A" position to enable air recirculation inside the cab.



- In "B" position to disable the air recirculation inside the cab and allow the ventilation system to draw air from the outside.



**NOTE**

The lever acts on the air "draw" by the ventilation system. The air flow and temperature must always be controlled by the ventilation system inside the cab.

7.1.10 - Air conditioning \*



**NOTE**

\* Air conditioning is an optional accessory.

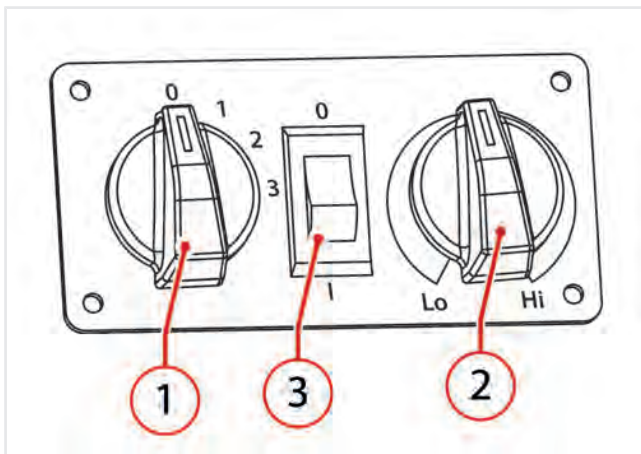

Figure: 161209-1

For a correct use of air conditioning, follow the following steps (fig. 161209-1):

1. Check that all doors and windows are closed.
2. Check that the heater is turned off by moving the lever towards the end of the blue scale.
3. With the engine running, turn on the air conditioning moving the switch "3" in position "1".
4. Turn the knob to adjust the airflow "1" to select the desired intensity.
5. Open and adjust the vents to obtain the best cooling according to the ambient temperature.
6. Turn the temperature knob "2" to obtain the desired temperature.



**ATTENTION**

**Turn on the air conditioning two minutes, every 15 days, even in the colder seasons with the engine idling (without**

**accelerating). In this way the moving parts, such as the compressor and the system in general are lubricated.**

To keep the air conditioning system efficient keep the condenser clean.



**DANGER**

**Do not loosen any hose of air conditioning systems in order to reach the capacitor since the contact between the skin and the refrigerant can cause frostbite.**

For maintenance and deadlines, see the "Maintenance" chapter.

7.1.11 - Cab lighting

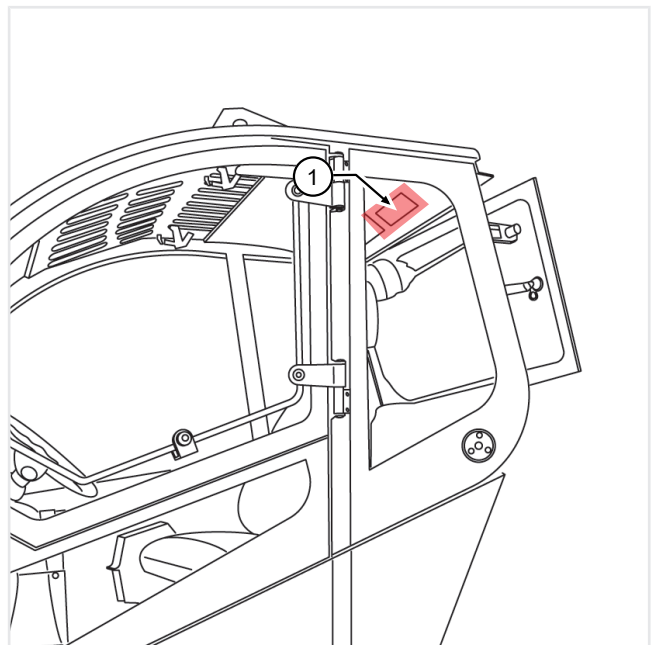

Figure: 150906-1

To turn on the lighting inside the cab act on the overhead light pressing one of the ends "1" (fig. 150906-1).

In the centre position the lighting is turned off.

### 7.1.12 - 12V Socket

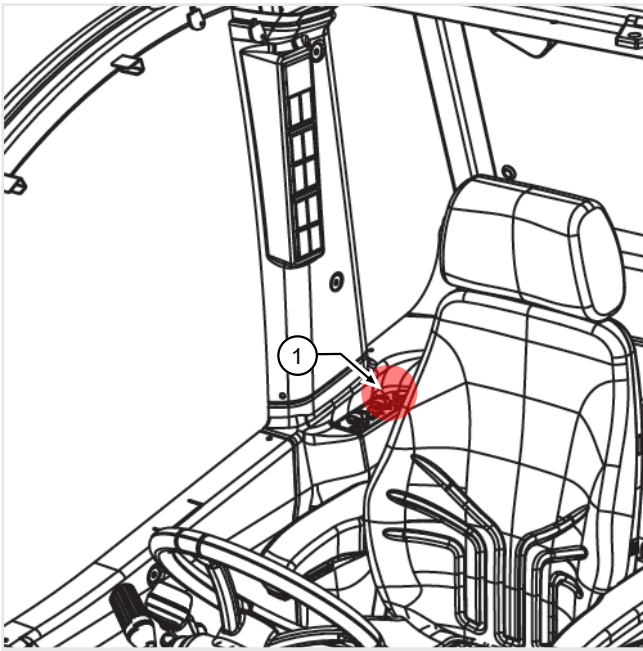

Figure: 150908-1

The 12V-180W socket "1" (fig. 150908-1) allows to connect direct current devices (battery chargers, cell phones, etc.).



#### WARNING

**Do not connect users with nominal voltage greater than 12V and power consumption greater than 180W.**

Risk of damage to the electrical system.

### 7.1.13 - Storage compartment

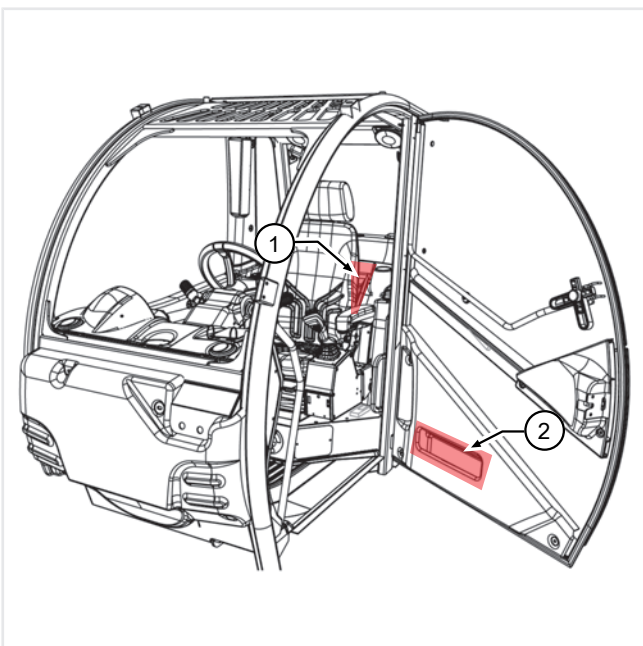

Figure: 150907-1

There are different storage compartments on the vehicle (fig. 150907-1):

1. Behind the seat
2. On the door

### 7.1.14 - Steering wheel

The steering wheel of the vehicle allows steering the vehicle wheels according to the steering mode set.



#### NOTE

Refer to the "Steering selector" chapter.

#### 7.1.14.1 - Steering wheel adjustment



150401-1



150401-2

To adjust the steering wheel angle (fig. 150401-1):

- Turn the steering wheel adjustment lever "1" (fig. 150401-2) down to unlock the movements.
- Push the steering wheel forward or pull it towards yourself to the desired position.
- Push down or pull up on the steering wheel to the desired height.
- Turn the steering wheel adjustment lever up to lock the steering wheel in the position in which it is located. For correct locking, screw firmly.



#### NOTE

The steering wheel is properly adjusted when the operator, with the back firmly against the backrest of the seat, is able to grasp the furthest side of the steering wheel while keeping the elbow slightly bent.

### 7.1.15 - Multifunction lever

The multifunction lever contains several functions: direction indicators, horn, headlights turning on, window wipers and washers.

7.1.15.1 - Direction indicators

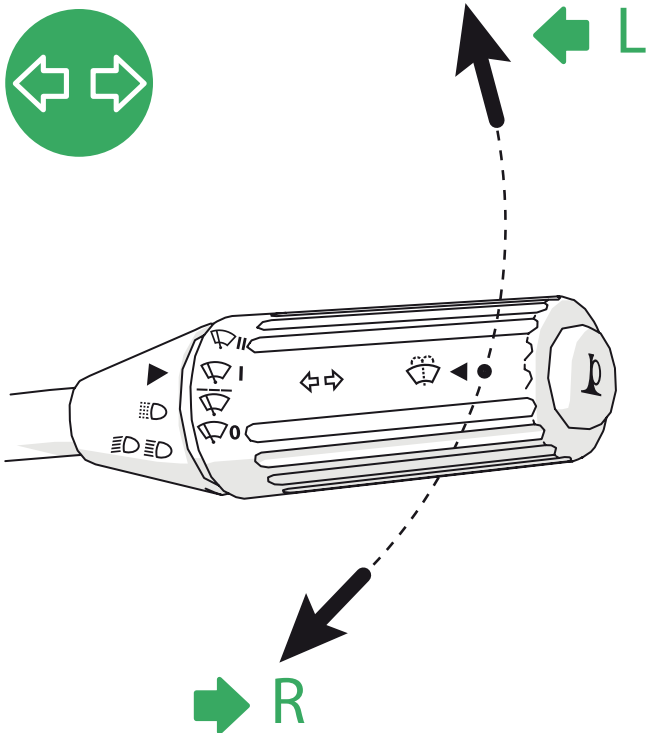

Figure: 150402-1

Move the lever (fig. 150402-1):

- Towards yourself to indicate a curve to the right (**R**).
- Forward to indicate a curve to the left (**L**).

The indicators only work when the ignition switch is in the position of instrumentation on.

The indicator light "1" on the central instrument panel will activate the direction indicators.



**ATTENTION**

Push the multifunction lever in stand-by position after making the turn, return to the neutral position is not automatic.

7.1.15.2 - Horn

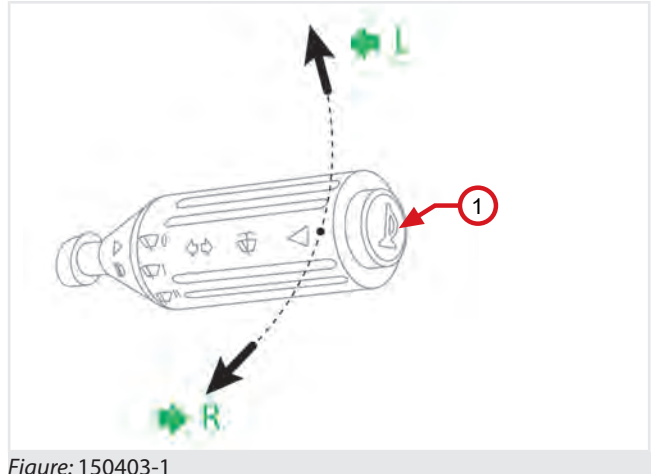

Figure: 150403-1

Press the button on the end of the lever "1" (fig. 150403-1), to activate the horn.

7.1.15.3 - Front window wiper

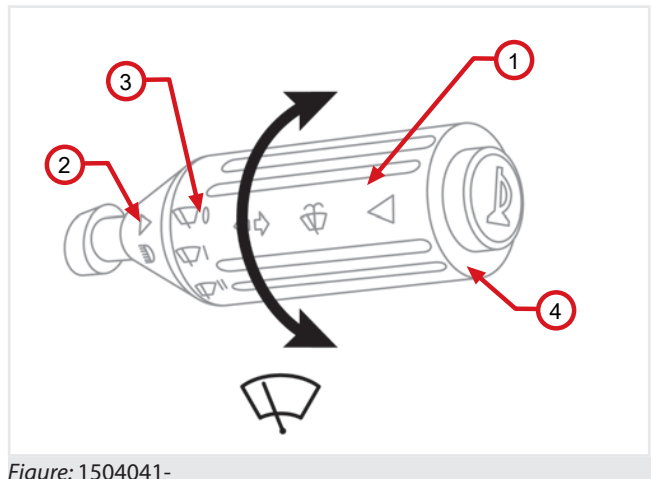

Figure: 150404-1

Turning the knob to "1" (fig. 150404-1) activates the front window wiper.

The arrow "2" indicates which window wiper mode "3" is currently active:

- 0 - Off
- I - Slow
- II - Fast



**WARNING**

**Worn blades cause viewing difficulties and scratches to the glass.**

Replace the blades if they are damaged or worn.

## 7.1.15.4 - Window washer

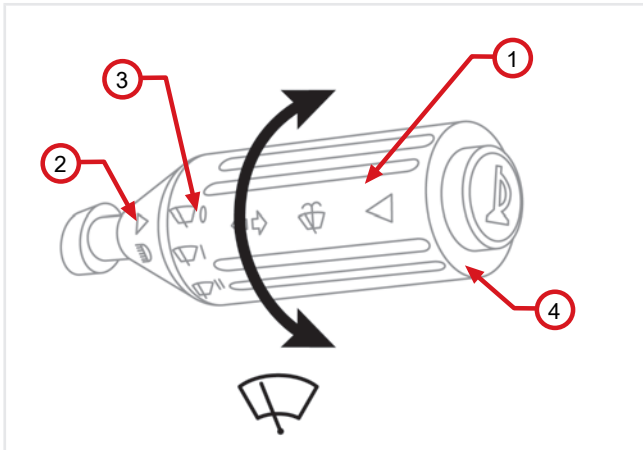

Figure: 150405-1

Press the middle button on the lever "4" (fig. 150405-1) to turn on the front window washer.

## 7.1.15.5 - Rear window wiper and washer

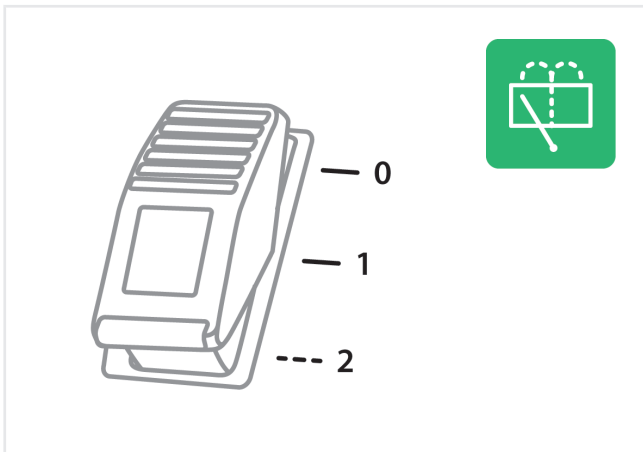

Figure: 150406-1

The switch of the rear window wiper and washer (fig. 150406-1) has 3 positions, 2 of which are stable and 1 unstable:

- 0 - Window wiper off
- 1 - Window wiper on
- (2) - Rear window wiper in operation, until pressed

## 7.1.16 - Lights turning on

## 7.1.16.1 - Sidelights and low beam lights

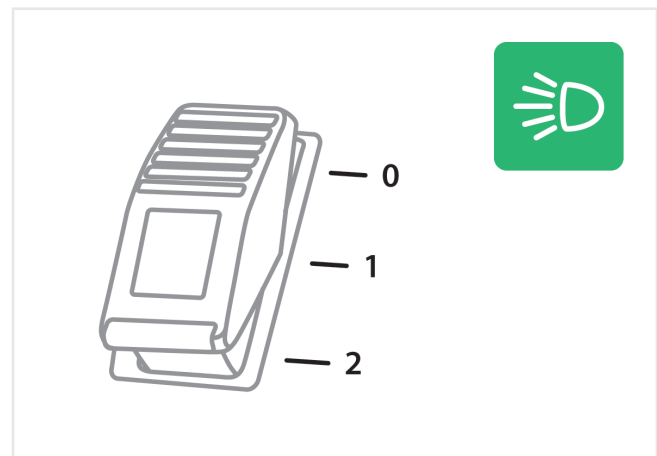

Figure: 150407-1

To turn on the front and rear side lights of the vehicle it is necessary to use the switch on the left instrument panel (fig. 150407-1).

The switch has 3 stable positions:

- 0- Lights off
- 1- Side lights on
- 2 - Low beam lights on

The side lights turned on is indicated by the indicator on the switch that turns on.

When the side light are activated the instrument panel of the vehicle lights on.

**NOTE**

It is possible to turn on the side lights with the ignition key in "0" position, while it is necessary to bring the ignition key in position "1" to turn on the low beam lights.

## 7.1.16.2 - High beam lights

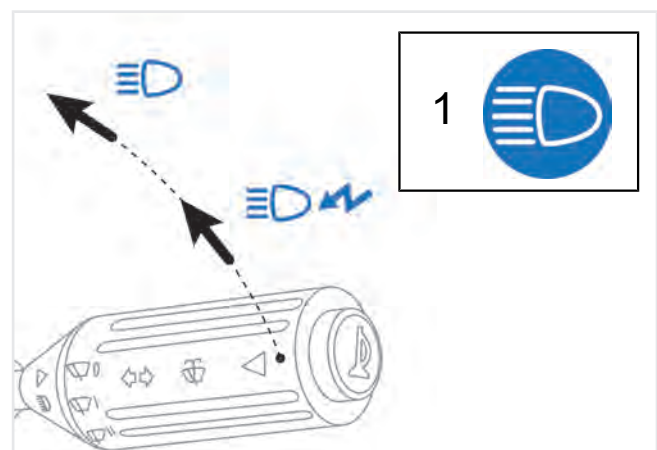

Figure: 150408-1

To turn on the high beam lights it is necessary to move the multifunction lever (fig. 150408-1).

- To make individual flashes with the high beam lights, pull the multifunction lever toward the steering wheel to the first click. It is possible to use this function with the lights off and the ignition key in position "0".
- To turn on the high beam lights, pull the multifunction lever toward the steering wheel to the second click. It is possible to turn on the high beam lights only with the ignition key in position "1" and low beam lights on. The high beam lights turned on is indicated by the warning light "1" on the instrument panel.

In both cases, once obtained the desired click, the multifunction lever returns to its rest position.

**7.1.16.3 - Cab front light \***



**NOTE**

\* The cab front light is an optional accessory.

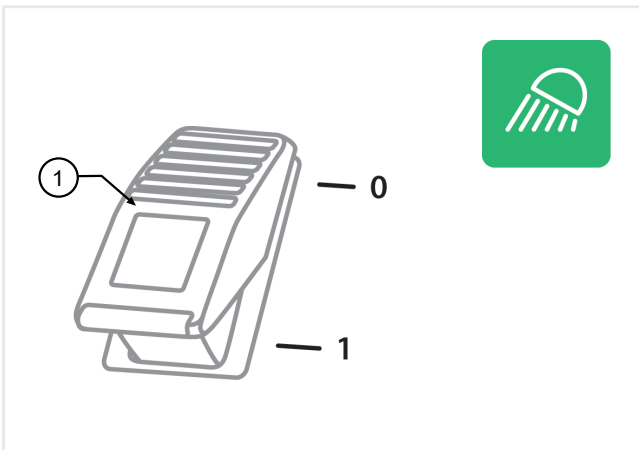

Figure: 150409-1

Press the switch "1" (fig. 150409-1) to turn on the front work light.

The warning light on the same switch indicates that the light is turned on.



**NOTE**

To turn on the headlight it is necessary to bring the ignition key in position "1".

**7.1.16.4 - Cab rear light \***



**NOTE**

\* The cab rear light is an optional accessory.

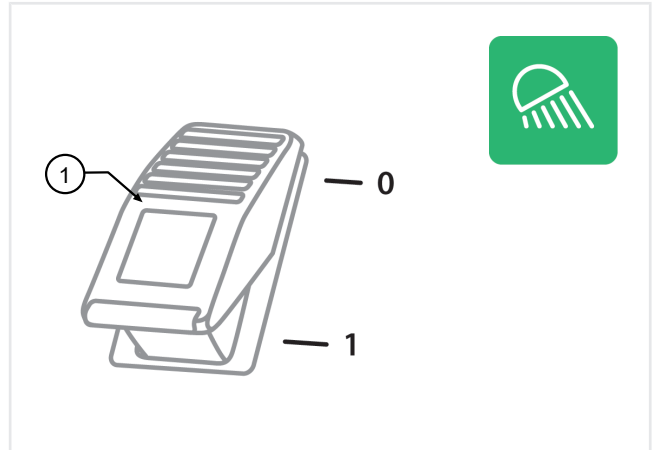

Figure: 150410-1

Press the switch "1" (fig. 150410-1) to turn on the rear work light.

The warning light on the same switch indicates that the light is turned on.



**NOTE**

To turn on the headlight it is necessary to bring the ignition key in position "1".

**7.1.16.5 - Work light on the boom head\***



**NOTE**

\* The work light on the boom head is an optional accessory.

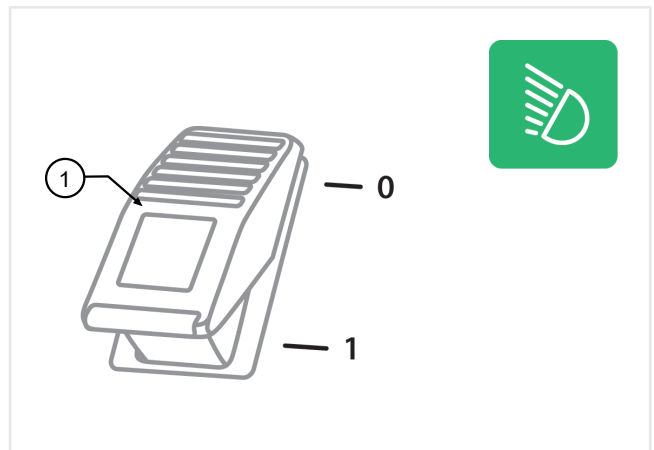

Figure: 150411-1

Press the switch "1" (fig. 150411-1) to turn on the work light on the boom head.

The warning light on the same switch indicates that the light is turned on.



**NOTE**

To turn on the headlight it is necessary to bring the ignition key in position "1".



### 7.1.16.6 - Rotating light

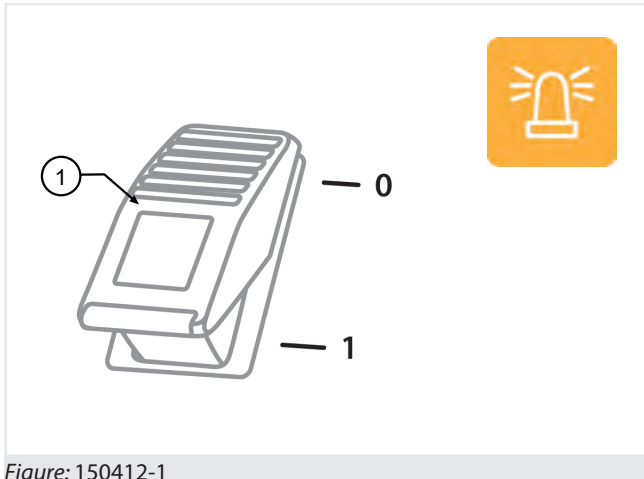

Figure: 150412-1

The rotating light "1" (fig 150412-1) must be positioned onto the driver's cab.

To activate and position the rotating light, perform the following steps:

1. Clean and dry the top of the driver's cab.
2. Place the rotating light on the cab.
3. Insert the plug of the rotating light into the electrical socket on the rear left side of the cab, under the rear glass.
4. Turn on the rotating light using the switch on the canopy instrument panel.

The rotating light turned on is indicated by the indicator light on the switch.



#### ATTENTION

##### Do not use the rotating light improperly.

Refer to the manager in charge of the work and to the regulations in force in the country of use of the vehicle to know the cases in which it is necessary and/or allowed to use the rotating light.



#### NOTE

It is possible to turn on the rotating light even if the ignition key is in the "0" position.



#### WARNING

##### Risk of damage to the electrical system.

Do not connect users with nominal voltage greater than 12V and power consumption greater than 180W.

### 7.1.17 - Emergency Lights

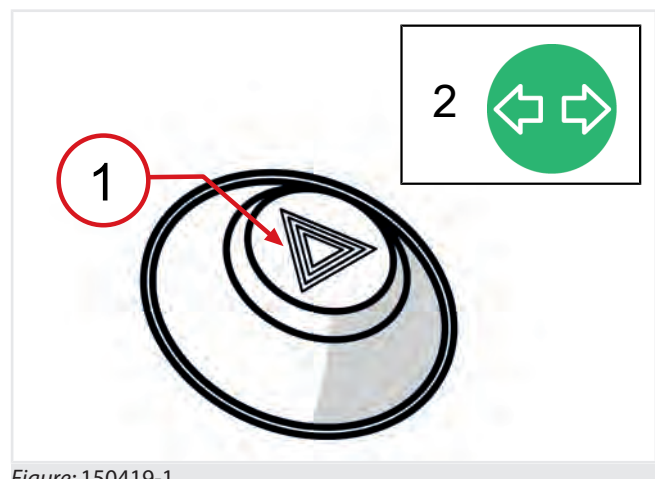

Figure: 150419-1

Press the emergency lights switch "1" (fig. 150419-1) to turn on all four direction indicators.

The side lights turning on is indicated by the switch flashing and by indicator "2" on the instrument panel of the vehicle.

### 7.1.18 - Seat

The seat of the vehicle is equipped with specific safety belts designed to protect the operator during the movement or handling operations.



#### WARNING

Always fasten the seat belts when operating the vehicle.

#### 7.1.18.1 - Deadman seat sensor



Figure: 150413-1

The vehicle is equipped with a safety system called "deadman" which consists of a magnetic sensor inside the seat cushion "1" (fig. 150413-1).

If the engine is running and the operator is not sitting properly in the driver's seat for a time longer than 3 seconds, the transmission is automatically disabled and the parking brake is engaged.

To continue moving the vehicle, the operator must sit in the driver's seat and set the movement selection lever in position "N".



**NOTE**

The engine can be started only if the operator is seated properly in the driving seat and the gear lever is in neutral "N".

7.1.18.2 - Seat adjustment



**ATTENTION**

**Correctly position the seat.**

The seat is properly positioned when the operator is able to perform a full stroke to the brake pedal by holding the back against the backrest of the seat itself.

The seat can be adjusted to different positions:

**Backrest inclination**

To adjust the inclination of the backrest (fig. 150418-1), lift the lever on the left side and let the backrest adapt to the required position. Release the lever to block the backrest.

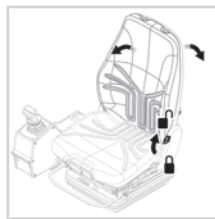

150418-1

**Back cushion**

Adjust the back cushion (fig. 150418-2) by turning the knob behind the backrest.

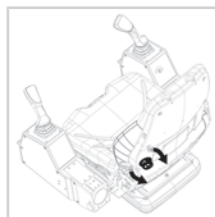

150418-2

**Horizontal position of the seat unit**

Adjust the entire seat unit longitudinally by moving the lever (fig. 150418-3) upwards and sliding the seat unit on the guides. Once established the desired position, release the lever. Perform small movements to make sure that the seat is fastened properly.



150418-3

**Horizontal seat position**

To adjust the seat longitudinally move the lever (fig. 150418-4) upwards and slide the seat unit on the guides. Once established the desired position, release the lever. Perform small movements to make sure that the seat is fastened properly.



150418-4

**Horizontal seat position**

To adjust the seat longitudinally, press the right handle (fig. 150418-5) and slide the seat along the guides. Release the handle when the desired position is reached. Perform small movements to make sure that the seat is secured properly.



150418-5

**Seat inclination**

To adjust the seat inclination, press the left handle (fig. 150418-6) and adjust the seat to the desired position. Release the handle when the desired position is reached. Perform small movements to make sure that the seat is secured properly.



150418-6



## Mechanical suspension degree

To adjust the degree of suspension (fig. 150418-7), turn the knob towards "+" to soften the suspension. Turn the knob towards the "-" to harden the suspension.

Optimal adjustment is achieved when the weight indicated at the side of the lever corresponds to the weight of the operator.



150418-7

## Pneumatic suspension degree \*



### NOTE

The pneumatic suspension of the seat is an optional accessory.

To adjust the pneumatic spring rate, pull the knob (fig. 150418-8) to let out pressure and soften the suspension. Push the knob to add pressure and harden suspension.

Pneumatic adjustment can only be performed with the engine running.



150418-8

## Adjusting the armrest

It is possible to lift or lower the armrest by hand (fig. 150418-9).

To adjust the height of the armrest when it is down, turn the knob located under it to the right to raise it, or to the left to lower the armrest.



150418-9

Before starting the vehicle, carefully examine the straps, buckles and fastening devices to the structure. If some component is damaged or worn, replace the seat belt or the component before operating the vehicle.

Remain seated with the seat belts fastened properly for all the time of operation of the vehicle to reduce the risk of injury in case of accident.

Following an accident of a certain importance, replace the seat belts, even if they do not appear damaged.

## To fasten the seat belt is necessary to:

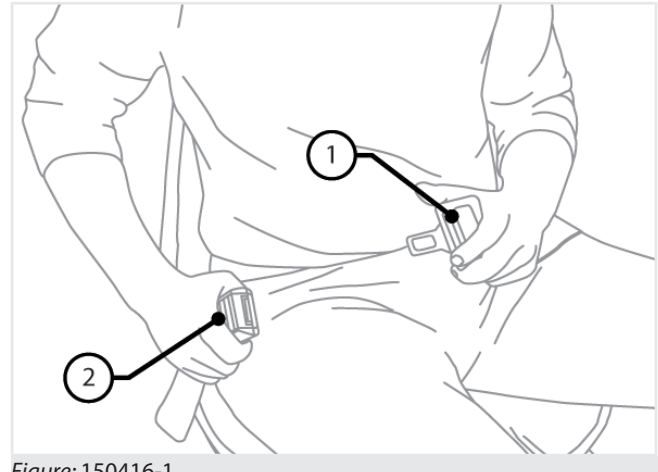

Figure: 150416-1

- Insert the latch plate "1" in the buckle "2".

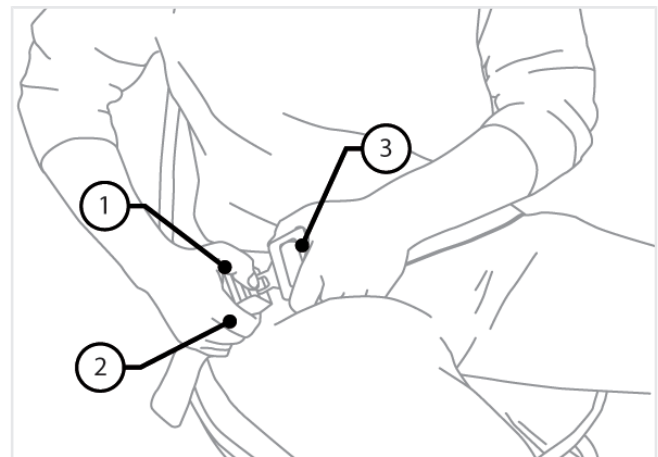

Figure: 150416-2

- Make sure of that the hooking occurred, and then adjust the belt around the body.
- The belt is considered properly connected when it is close to the body.

### 7.1.18.3 - Seat belts



### WARNING

**Always fasten the seat belts when operating the vehicle.**

The machine is equipped with a cab that can withstand the weight of the machine in the event of rollover (ROPS), it is therefore necessary that the operator remains tied to the seat by the seat belt not to be swept out and possibly crushed.

To remove the belt it is necessary to:

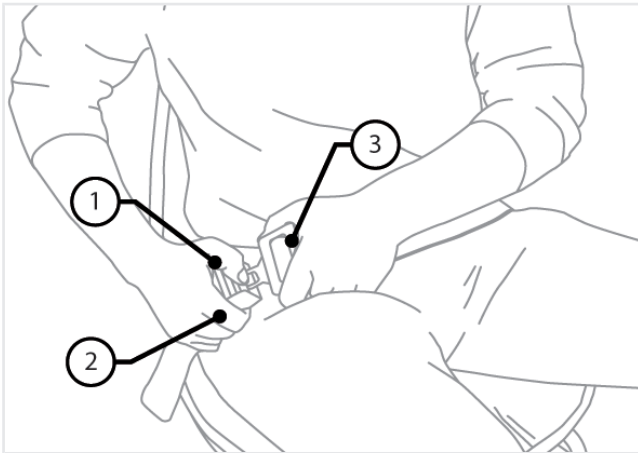

Figure: 150416-3

- Press the red button "1" on the buckle "2".
- Then remove the latch plate "3".



**WARNING**

**Drive the vehicle only with safety belt properly worn, fastened and adjusted.**

Operating without the seat belt fastened increases the risk of accidents.

Do not use damaged or worn seat belts. If worn, damaged or yielded belts are used, they can break or yield in case of collision resulting in serious injury to the operator.

**7.1.19 - Emergency stop**



In emergency conditions, the machine can be stopped using the Emergency stop buttons.



**ATTENTION**

It is recommended to use the emergency stop button only in case that there is an immediate danger to the operator, to the load and/or to the integrity of the vehicle.

The pressure exerted on the emergency stop button activates the power supply cut-off and the consequent complete shutdown of the vehicle and any connected equipment.

The return to normal working conditions, after a stop caused by the emergency stop button, is only possible after:

- Removal of the cause that caused the stop
- Releasing the emergency stop button

To release the emergency stop button, rotate it in the direction indicated by the arrow printed on the button.

**7.1.20 - Spirit Level**

The spirit level is located in the center of the instrument panel. It is used to verify the correct transverse leveling of the vehicle.

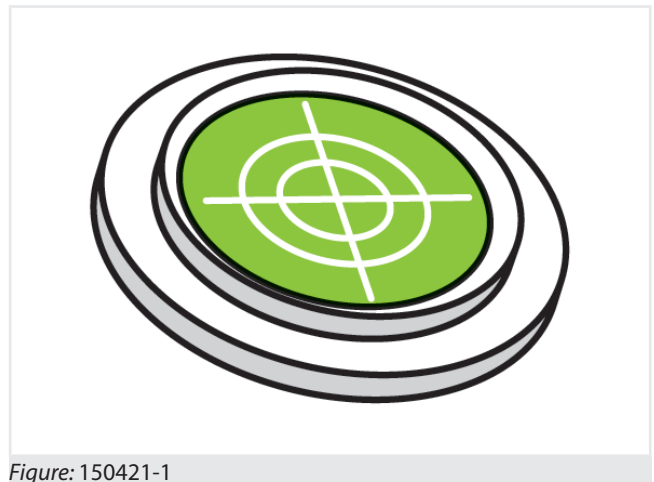

Figure: 150421-1

To safely operate the spirit level must in the center, with a maximum approximation of 2° to the right or left.

In the standard spirit level, the angle exceeds 2° when the spirit level moves completely outside the 2 limit marks of 2°.



**DANGER**



**DANGER OF TRANSVERSE TIPPING.**

To safely operate the spirit level must in the center, with a maximum approximation of 2° to the right or left.

### 7.1.21 - Emergency exit: Rear glass

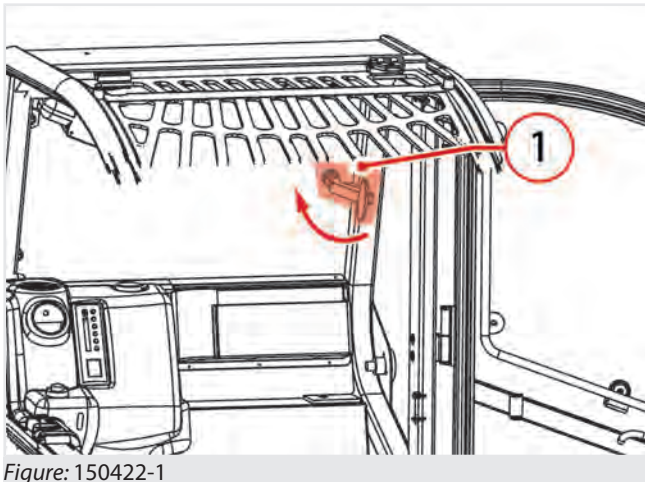

Figure: 150422-1

The rear glass of the cab (fig. 150422-1) can be used as an emergency exit in case the vehicle doors are locked.

To open the window fully, slide the fastener to "1" and push the glass outward.

The fastener must always be positioned as shown in the figure during normal work operations.



#### DANGER

##### **Danger of crushing.**

It is prohibited to fully open the glass during the use of the vehicle, because of the shearing risks between the boom and the chassis.

The rear glass is near the telescopic boom.



#### WARNING

Be very careful when opening and/or removing the glass, as this may chip or crush and may cause injury to the operator in the cab and to who is near the vehicle.

### 7.1.22 - Cab front glass protection \*



#### NOTE

\* **The windscreen protection grill is an optional accessory.**

Consult your dealer in case of doubts or information on your vehicle.

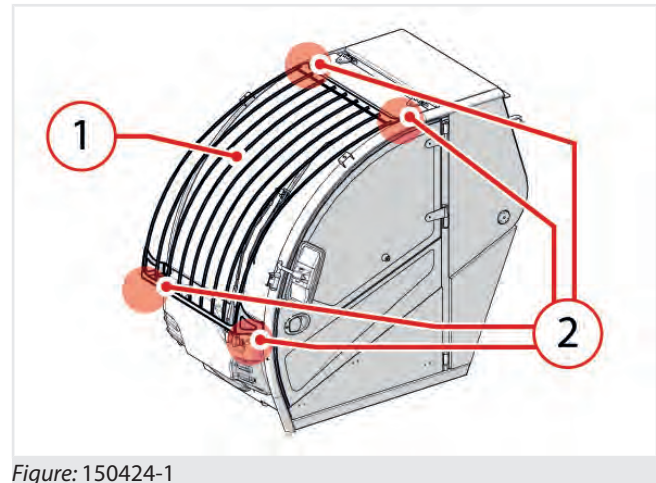

Figure: 150424-1

The Cab front glass protection "1" (fig. 150424-1) provides a higher protection level against any large/heavy loads or objects, which may fall on the cab.



#### ATTENTION

**Driving the vehicle on public roads is allowed only with the Cab front glass protection disassembled.**

Carry out the following operations to disassemble the cab front glass protection:

- Lay the load, if any, on the ground,
- Place the vehicle on a level ground,
- Lift the vehicle boom,
- Turn off the vehicle,
- Get off the vehicle and climb on the walkable surface on the front of the vehicle,
- Loosen the knobs "2" (fig. 150424-1) that fasten the Cab front glass protection, starting from the top,
- Lift the Cab front glass protection and place it on the floor.

### 7.1.23 - Warnings in case of vehicle tipping

- The seat belt is the best guarantee of protection for you in case of lateral or front tipping of the vehicle
- Stay calm: stay on board, do not try to jump out of the driver's seat
- Hold the steering wheel with both hands
- Push your feet strongly on the floor, keeping them within the driver's seat
- Tilt your body in the opposite direction to that of the fall

- To avoid head impact, move your head as much as possible towards the steering wheel

## 7.2 - Parking brake

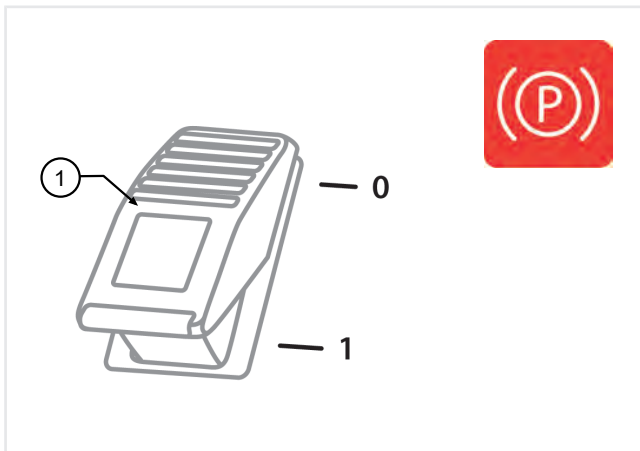

Figure: 150454-1

To engage the parking brake, press the switch to "1" (fig. 150454-1).



150454-2



150454-3

The parking brake properly engaged is indicated by the lighting of the switch and by the indicator on the instrument panel of the vehicle (fig. 150454-2).

With the parking brake engaged, the vehicle cannot move; the hydrostatic transmission is switched off and the wheels are braked.

The parking brake must be engaged:

- Every time the operator leave the vehicle, even in case of momentary stop
- Whenever the vehicle operates from a standstill even with outriggers down (if any)

The brake engages automatically when the engine is stopped.



### WARNING

Unauthorized modification of axle ratios, vehicle weight, size of wheels and tires can affect the efficiency of the parking brake.



### NOTE

To verify the efficiency of the parking brake contact a **DIECI** authorized workshop.



### DANGER

**RISKS: In case of failure of the parking brake do not use the vehicle.**

If the warning light (fig. 150454-3) turns on intermittently, it indicates a low brake fluid level.

If the warning light (fig. 150454-3) turns on in a fixed way, the parking brake is stuck or damaged.

Do not use the vehicle until the problem has been solved. Contact a **DIECI** service center.

## 7.2.1 - Pressure gauge



Figure: 150742-1

The pressure gauge (fig. 150742-1) is used to control the servo brake pressure. In case of anomalies and faults, the pressure may drop.



### DANGER

**The pressure should not drop below 18 bar (1.8 MPa – 260 psi).**

In the case of low pressure (below 18 bar) stop the vehicle and contact an authorized Dieci dealer to eliminate the defect.



### DANGER

It is absolutely forbidden to operate with servo brake accumulator pressure less than 18 bar (1.8 MPa – 260 psi).

## 7.2.2 - Braking circuit errors list



### NOTE

In case the vehicle is in error, contact a **Dieci** service center to solve the problem, indicating the error code reported.

For more information about the errors display, refer to the "Instrument panel" chapter.

Icon	Example	Description
	000000000	Parking brakes errors or brakes failure

Code	Description
100	Service brakes low oil level reporting
101	Parking brake system failure
102	Parking brake accumulator low pressure

## 7.2.3 - Deactivating the internal parking brake manually

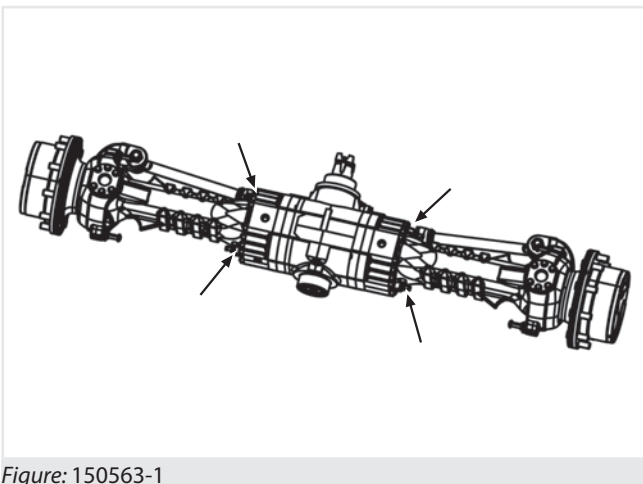

Figure: 150563-1

The parking brake must be disengaged directly on the axle to allow the vehicle to be towed.

- Place safety wedges under the wheels to prevent the vehicle from moving suddenly
- Loosen the lock nuts on both sides of the central body of the axle.
- Tighten the screws until they meet resistance; check the turns made in order to return the screws into the starting position when the towing operations are completed.
- Tighten the screws further 1.5 turns.
- In this way the brake will be released. After the towing return everything to the initial conditions.

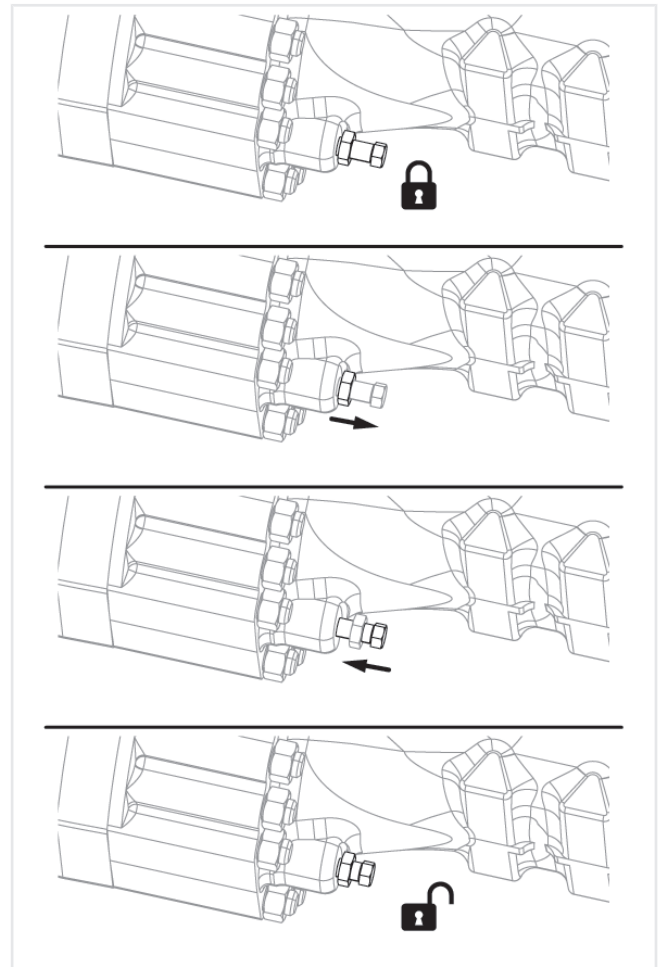

Figure: 150563-2



### DANGER

**Never use the vehicle with the negative parking brake disengaged/disconnected.**

After the towing return everything to the initial conditions.

It is very important to re-tighten the screws with the same number of turns with which they are loosened.



## 7.3 - TFT Instrument panel

### 7.3.1 - Components

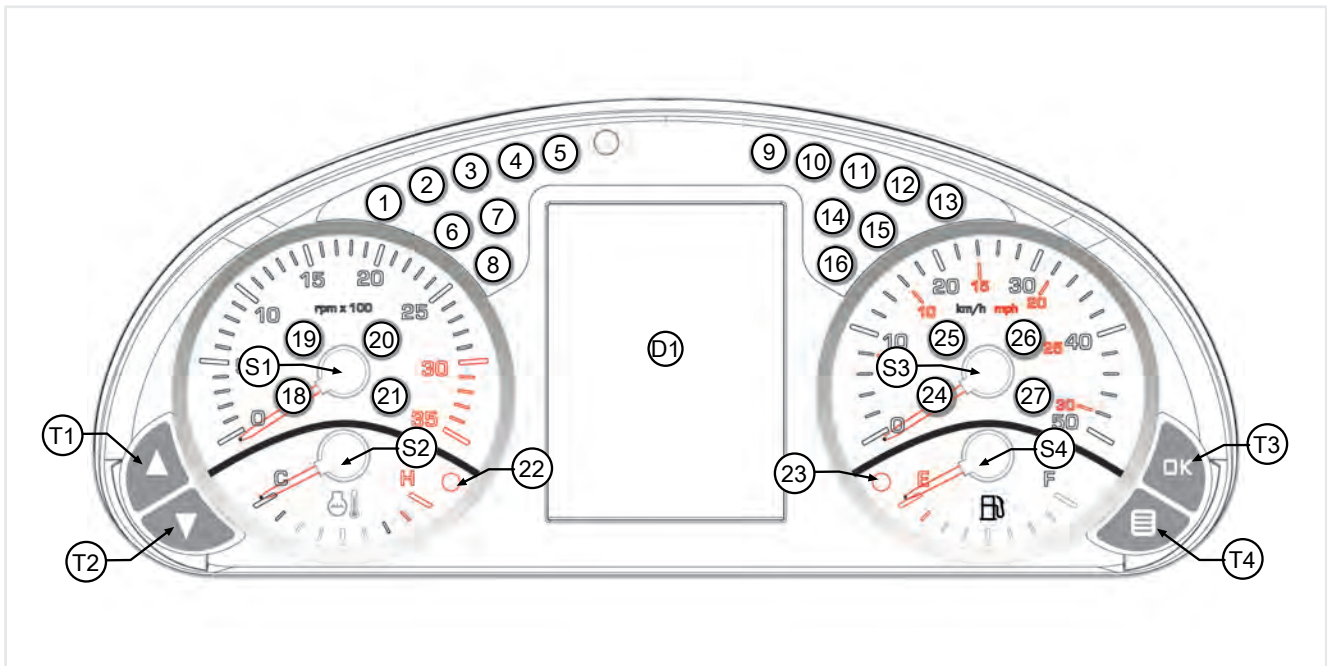









Figure: 150425-1 - Instrument panel components

Position	Indicator light	Description		
T1	-	-	-	UP button
T2	-	-	-	DOWN button
T3	-	-	-	OK button
T4	-	-	-	MENU key
D1	-	-	-	Display
S1	-	-	-	Tachometer indicator
S2	-	-	-	Engine water temperature indicator
S3	-	-	-	Speed indicator
S4	-	-	-	Fuel level indicator
1		Red	Fixed	Generator, battery failure
2		Red	Fixed	Engine oil low pressure
3		Yellow	Fixed	Glow plugs
4		Red	Fixed	Parking brake insufficient pressure
5		Red	Fixed	Engine air filter clogging
6		Red	Fixed	Hydrostatic oil filter clogging
7		Red	Fixed	Hydraulic oil high temperature

Position	Indicator light		Description
8		Green Fixed	Forward movement engaged
9		Red Fixed	Parking brake engaged
10		Flashing	Brakes oil low level
		Fixed	Braking system failure
11		Green Fixed	
12		Yellow Fixed	Slow gear engaged *
13		Yellow Fixed	Fast gear engaged *
14		Yellow Fixed	Front axle wheels alignment *
15		Yellow Fixed	Rear axle wheels alignment *
16		Green Fixed	Backward movement engaged
17	-	- -	Not used
18		Blue Fixed	High beam
19		Green Fixed	Direction indicators
21		Green Fixed	Side lights
22	-	Red -	Engine water high temperature
23	-	Yellow -	Fuel reserve

\* Indicator lights used depending on configurations or optional equipment.

Position	Indicator light		Description
20		Red Fixed	General alarm
24		Yellow Fixed	Not used
25		Yellow Fixed	Not used
26		Yellow Fixed	Not used
27		Red Fixed	Not used



**7.3.2 - Initial check**

When the panel is switched on, the system will perform a check of all the indicator lights and all the indicators. During the check, the screen will show the software versions "1" and a loading bar "2" (fig. 150922-1).

After completing the initial check the display shows the main Home screen.

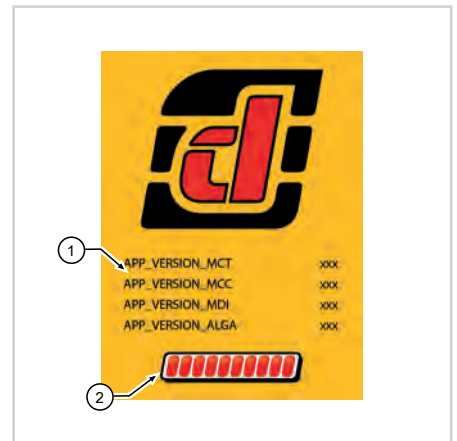

150922-1

**7.3.3 - Home**

The Home screen (fig. 150428-1) is the standard display, containing the information required by the operator to use the vehicle.

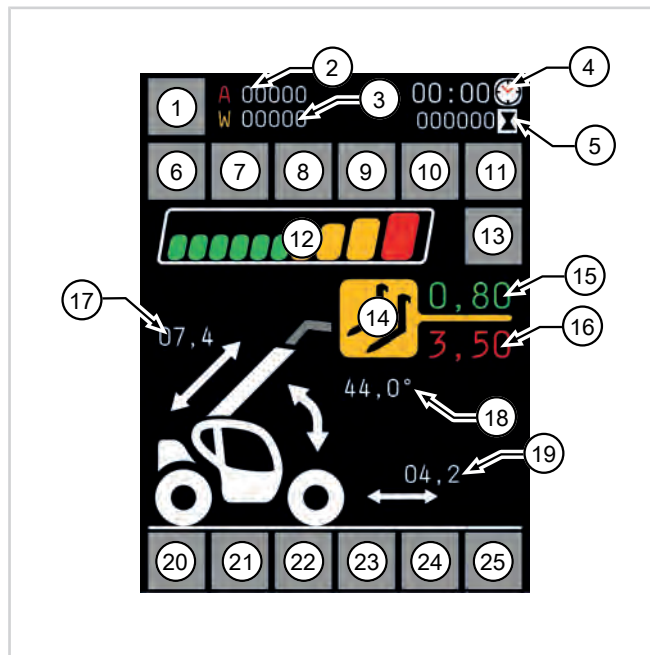

150428-1

Position	Description
1	General alarm icon
2	Indicates the active alarms codes
3	Indicates the active warning codes
4	Clock and clock setting [ ▶ 84]
5	Hour meter [ ▶ 84]
6	Levelness Icon [ ▶ 85]
7	Service [ ▶ 89]
8	Not used
9	Steering mode icon [ ▶ 85]

Position	Description
10	Limits [ ▶ 90]
11	ByPass key [ ▶ 92]
12	Longitudinal movement indicator and anti-tipping icon [ ▶ 93]
13	Longitudinal movement indicator and anti-tipping icon [ ▶ 93]
14	Selected equipment
15	Weight currently carried
16	Maximum transportable weight according to the equipment installed and vehicle working mode
17	Length of extension
18	Degrees of inclination of the boom with respect to the turret
19	Load height from the ground
20	Function Icon for special equipment [ ▶ 85]
21	Change Direction Alarm Icon [ ▶ 86]
22	Not used
23	Not used
24	--- MISSING LINK ---
25	Not used

### 7.3.4 - Clock and clock setting

On the home screen there is the indication of the time next to the related icon (fig. 150927-1).



150927-1

To adjust the time it is necessary to (fig. 150927-2):

- Press the **MENU** button,
- Select the clock setting icon,
- Press the **OK** button,
- Use the **UP** and **DOWN** to set the hour digits,
- Press the **OK** button,
- Use the **UP** and **DOWN** to set the minutes digits,
- Press the **OK** button to set the new time.

Press the **MENU** button at any time to cancel the process and return to the Home screen.

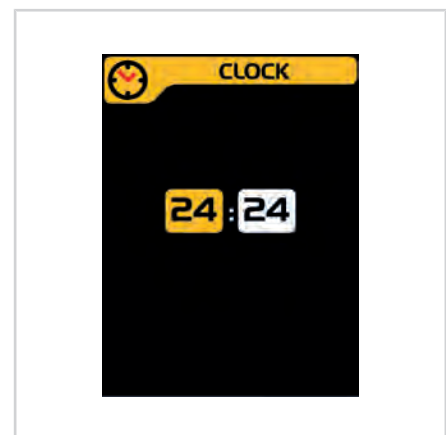

150927-2

### 7.3.5 - Hour meter

On the home screen there is the indication of the hour meter next to the related icon (fig. 150928-1).





150928-1

The separation of the decimal point flashes when the hour meter is active.

### 7.3.6 - Levelness Icon

The levelness icon indicates when the vehicle is in a working condition within the maximum tilting limits set by the manufacturer.

A		Green	The icon indicates that the vehicle is within the working limits and can operate normally.
B		Red	The icon indicates that the vehicle is out of the allowed tilting limits and must be levelled in order to proceed with the work.

When working with the man basket, the pilot light "B" turns on together with an acoustic signal that can be silenced by pressing the "OK" button on the instrument panel.

It is possible to see the exact values on the outriggers page, by holding down the "Outriggers consent" button.

### 7.3.7 - Steering mode icon

The Steering mode icon shows the steering mode currently selected and operating.

Icon	Description
	Front steering wheels
	Four steering wheels
	Transverse steering

To change the steering mode refer to chapter Electrical steering selector [▶ 98].

### 7.3.8 - Function Icon for special equipment





#### NOTE

The Function Icon for special equipment is an optional accessory.

The Function Icon for special equipment indicates the function of the active equipment.

For more information, refer to the manual of the special equipment installed on the vehicle.

A		Blue	Function 1
B		Blue	Function 2
C		Blue	Function 3

D		Blue	Function 4
---	---	------	------------

### 7.3.9 - Change Direction Alarm Icon

The "Change Direction Alarm" icon (fig. 151170-1) lights up when the vehicle is being reversed with the movement selection lever at high speed.

To prevent damage to the vehicle, the system reduces the engine rpm, puts the vehicle in neutral and brakes up to the speed at which the reversing is permitted.



151170-1

**7.3.10 - Menu**

From the Home screen, it is possible to access the menu (fig. 150923-1) pressing the **MENU** key.

Use the **UP** and **DOWN** buttons to scroll through the menu items and press the **OK** button for 3 seconds to make a selection and go to the related page.

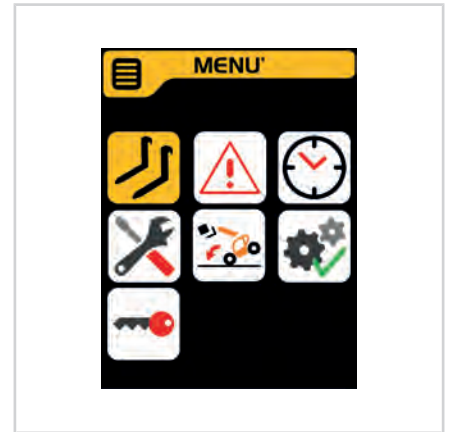

150923-1

The menu items are:

Icon	Menu
	Available equipment menu
	Active errors [ ▶ 88]
	Clock and clock setting [ ▶ 84]
	Service [ ▶ 89]
	Anti-tipping calibration (Reserved to qualified personnel)
	Diagnostics (Reserved to trained personnel)
	Settings (Reserved to qualified personnel)
	Limits [ ▶ 90]

### 7.3.11 - Active errors

The presence of errors will be reported by the general warning icon, by the acoustic signal lasting 1.5 sec. and by the displaying of the error code on the Home screen instead of the time.



150432-1

In the presence of more than one error, the error codes will be displayed cyclically every 2 sec. on the Home screen. At the end of the cycle showing all the active errors, an icon will be displayed that indicates the user to access the Active Errors page to view all active errors in that time.

In case of an error from the SAR, the acoustic signal will be continuous and the error code will remain fixed on the Home screen. Press the **OK** button to stop the sound of the acoustic signal and resume the active errors displaying cycle.

To enter the Active errors page it is necessary to:

- Press the **MENU** button,
- Select the Active errors icon,
- Press the **OK** button,

Use the **UP** and **DOWN** buttons to scroll through the pages if there are several errors. The arrows at the bottom of page "1" indicate the presence and directions in which the additional pages flow.

Press the **MENU** button at any time to return to the Home screen.

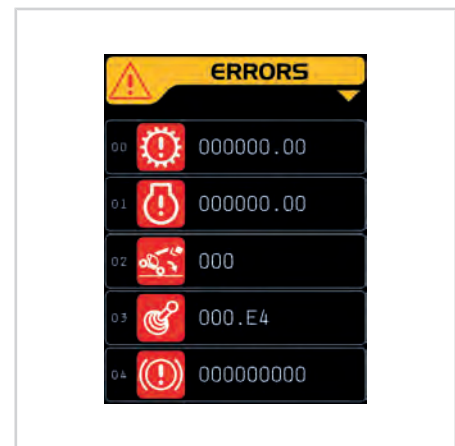

150432-2

Each error code is associated with an icon that identifies the nature of the error:

Icon	Example	Description
	000000000	Parking brakes errors or brakes failure
	000	SAR errors
	000000.00	Transmission errors
	000000.00	Engine errors
	000.E4	Joystick errors

### 7.3.12 - Service

The Service icon indicates intervals at which to carry out maintenance on the vehicle (fig. 150925-1).

20 hours before the deadline, the icon stays on for 3 seconds after switching on the instrument panel.

The Service indicator icon stays on permanently if, at the end of deadline, maintenance is not carried out by specialized personnel.

To find out the hours remaining to next maintenance, it is necessary to access the Service page (fig. 150925-2):

- Press the **MENU** button,
- Select the Service icon,
- Press the **OK** button.

To return to the Home screen, simply press the **MENU** button or select the **BACK** icon "1" and press the **OK** button.



150925-1

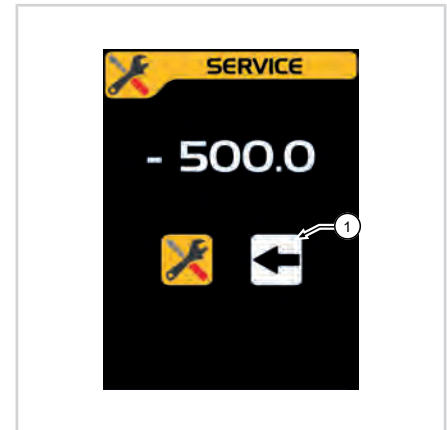

150925-2



#### NOTE

Contact the Dieci technical service to perform maintenance and reset the Service hour counting.



### 7.3.13 - Limits

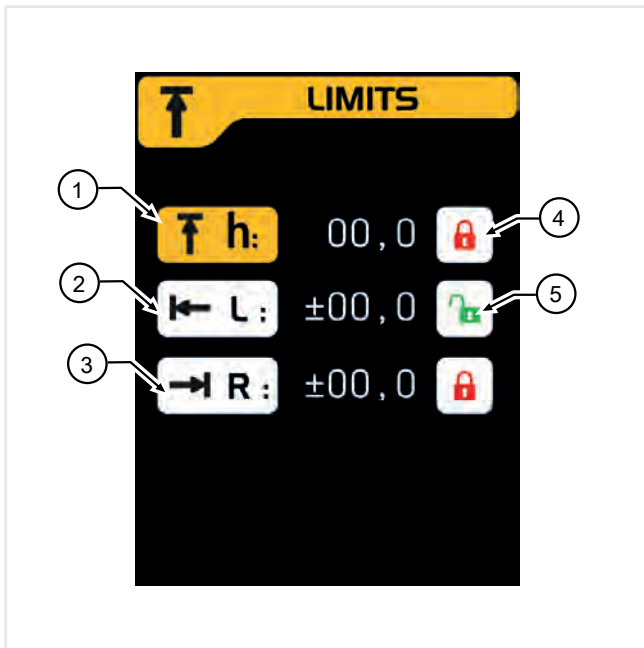

Figure: 150933-1

To access the Limits page:

- Press the **MENU** button,
- Select the Limits icon,
- Press the **OK** button.

On the Limits window it is possible to set a limited work area for the boom and turret movement, for example in case it is necessary to work in the vicinity of buildings or dangerous structures.

This page includes (fig. 150933-1):

- 1 - Upper area limit
- 2 - Left area limit
- 3 - Right area limit
- 4 - Active limit indicator light
- 5 - Deactivated limit indicator light

#### Setting a limit

To set a limit, take the machine to the limit position of the area in which it must stop automatically during the work, select the desired limit with the **UP** and **DOWN** arrows and press **OK**. The value will be blocked and indicated by the active limit indicator light.

After setting a limit the HOME window will show the active Limit indicator light.

During the working process, when a set limit is reached, the following indicator lights will be displayed:

Icon	Description
	Active limit indicator light
	Upper limit reached indicator light
	Right limit reached indicator light (only for rotary vehicles)
	Left limit reached indicator light (only for rotary vehicles)

#### Removing a limit

To remove a previously set limit, it is necessary to access the Limits window and select the limit to be removed with the **UP** and **DOWN** buttons and press **OK**. The correct deactivation will be indicated by the deactivated Limit indicator light "5" (fig. 150933-1) located aside of the value.

### 7.3.14 - Anti-tipping device

The vehicle is equipped with an anti-tipping device that has the purpose to help the operator to use the vehicle safely with different acoustic and visual warning signals according to the vehicle overturning danger.

The anti-tipping device is always active.



#### WARNING

**This device can not replace the good experience of the operator in using the vehicle safety; the operator is the only one responsible for the safe operation of the vehicle and compliance with all safety standards prescribed.**

The operator must be able to determine if the data provided by the instrument are correct and real, using them for a safe use of the vehicle. When checking the loaded weight, make sure that this is lifted from the ground. When turned on, the device starts a self-diagnostic program to check the proper operation of itself and of the transducers. In case of failure, the device sets itself in a safety state and stops the operations.

Therefore the operator, before starting to work, must make sure that the instrument operates correctly:

- Correct settings check.
- Check for messages and alarms on the panel.
- Check that the device operates correctly.

The operator must, in case of any type of anomaly, to immediately contact an authorized workshop or a DIECI authorized service center.



#### WARNING

**The operator is responsible for selecting the correct settings depending on the equipment installed on the vehicle. When it is turned on, the last configuration used is set automatically until it is changed.**

An incorrect setting of the accessory may cause undesired operation of the device and therefore create a dangerous situation of operation.

It is not possible to use the vehicle with equipment other than that set on the device.

### 7.3.14.1 - Anti-tipping device description

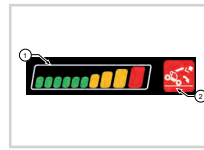

150931-1



150931-2

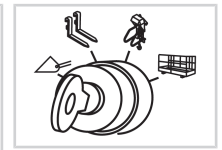

150931-3

The device is composed of:

- Longitudinal momentum indicator (fig. 150931-1)
- Bypass key (fig. 150931-2)
- Mode selection key (fig. 150931-3)

**The device is always in operation.**

The device is not intended for warning about the risk of tipping in case of:

- Transverse overturning
- A sudden overload,
- Transport/movement with the load in an elevated position,
- Movement on rough terrain, with obstacles or holes;
- Transport/movement on a slope or in the vicinity of a slope;
- High speed of movement on straight lines and on turns.



#### ATTENTION

When the limit load is reached, the device automatically locks all the aggravating movements for the stability of the vehicle. Only the movements that allow to return the vehicle in safety conditions will remain active.

### 7.3.14.2 - ByPass key



## DANGER



### Danger of tipping

The ByPass Key must be used only if all of the following conditions occur:

- In case the maximum tipping limit and danger of vehicle overturning has been reached.
- By skilled and properly trained personnel
- For short periods of time
- After trying to restore the safety conditions through the vehicle movements that remained active.
- In case it is not possible to restore the safety conditions through the vehicle movements that remained active.

The ByPass Key (fig. 150932-1) is with hold down action, therefore, must be maintained rotated during the operation for setting the vehicle in safe conditions.



Figure: 150932-1

Keep the ByPass key turned and simultaneously use the joystick to return the vehicle in safety conditions.

When using the ByPass key, the display will show the related icon "3" (fig. 150932-2).



150932-2

The ByPass Key function turns off automatically after 30 seconds, even if the key continues to be rotated.

After reaching the safety zone, the alarm stops and the ByPass key can be released.



## DANGER



It is prohibited to use the Bypass key to operate with loads that exceed the capacities established by the manufacturer.



## DANGER



**DO NOT MAKE THE DESCENT OR THE EXTENSION OF BOOM MOVEMENTS AS THEY ARE AGGRAVATING MOVEMENTS FOR THE TIPPING.**

When using the bypass key, only make the return or the slope of the telescopic boom, bringing this in safety situation.



## WARNING



When using the bypass key the anti-tipping systems are disabled.

It is mandatory to consult the load charts of the vehicle and the equipment installed before performing any manoeuvre.

Use the data displayed on the instrument panel and the letters on the boom to know the exact position of the load.

In these conditions do not perform aggravating movements for the stability of the vehicle, there is a danger of loss of stability and tipping.



## NOTE

The bypass function is performed by a key to give the possibility to the Safety Officer to extract the key to prevent deactivating the anti-tipping system during normal working conditions.

**7.3.14.3 - Longitudinal movement indicator and anti-tipping icon**

The tipping indicator is displayed by a bar "1" (fig. 150931-1), which indicates the vehicle risk of tipping.

When the vehicle is about to reach the tipping, the Tipping hazard icon "2" starts flashing. It will stop flashing when the vehicle returns within the safety parameters.

The degree of stability of the vehicle is indicated by:

- Tipping status bar "1"
- Signalling icons "2"
- Acoustic signalling

The signalling increases proportionately to the vehicle tipping risk increase during load handling operations, as described in the table below.

When the limit load is reached, the device stops the movements of the vehicle considered aggravating, the alarm stops when the safety conditions are restored.

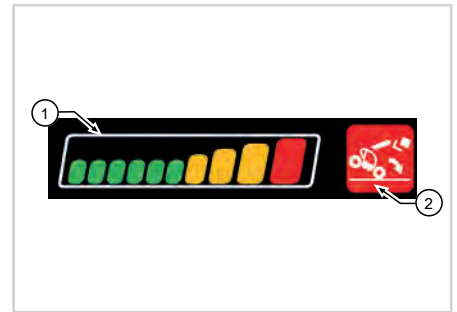

150931-1

Load	Icon	Status bar	State	Condition	Acoustic signalling
Load 90% less than the maximum allowed load		Within the green zone	Steady on	Work in safe conditions	None
Load 90% greater than the maximum permitted load		Yellow zone start	Flashing	Pre-alarm condition	Intermittent
Load at 100% of maximum allowed load		Red zone start	Steady on	Vehicle at the tipping limit	Continuous
Load 100% greater than the maximum permitted load		Red zone end		Aggravating movements lock	Continuous

### 7.3.14.4 - Operating modes key

The vehicle is designed for use with different types of equipment, therefore it is necessary to set the correct operating mode according to the equipment used at that time.

To select the operating mode required for the equipment, use the operating mode key moving it to the work mode symbol (fig. 150437-1).

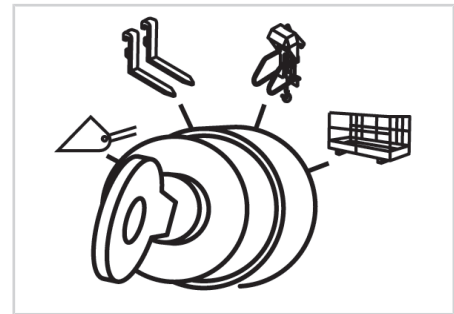

150437-1

The operating modes are:

Symbol	Operating mode	Description	Combined equipment
	Bucket	To be used during digging	<ul style="list-style-type: none"> <li>• Bucket</li> <li>• Mixing buckets</li> </ul>
	Telescopic elevator	To be used to transport materials	<ul style="list-style-type: none"> <li>• Forks</li> <li>• Ladles</li> <li>• Material basket</li> </ul>
	Mobile crane	To be used to lift materials	<ul style="list-style-type: none"> <li>• Equipment with hook</li> <li>• Equipment with winches</li> </ul>
	Elevating work platform *	To be used to lift persons, it enables the controls on the basket	<ul style="list-style-type: none"> <li>• Man basket</li> </ul>

\* The "Elevating Work Platform" operating mode for lifting persons is provided only with the "Man basket pre-arrangement" option.



## WARNING



**The anti-tipping device state can be changed by a key to give the possibility to the Safety Officer to extract the key preventing to use a mode different than the selected one.**

The safety officer must ensure that the operator is informed, educated and trained in the use of the vehicle in the set mode.



## WARNING

**It is forbidden to use the vehicle with equipment other than that selected using the "Operating mode selector".**

The equipment applicable to vehicles in question refer to **DIECI** price list.

### Operating mode: Bucket

Bucket Mode, boom fully retracted, the anti-tipping device is automatically disabled. In case the boom is extracted or is subsequently extracted the operation will be with the same mode of the forks.

In this mode:

- The device always works properly and only indicates the load status.

- With closed boom the acoustic signal is not working to report the state of the load, but it starts operating only for reporting system errors.

**DANGER**

If accessories other than those specified as combined equipment is used in "Bucket" mode there is a risk of tilting.

---

### Operating mode: Elevating work platform

**WARNING**

It is allowed to use the basket from the cab with "forks" operating mode only to return the basket to the ground in the event of illness or injury of the operator is in it.

---

### 7.3.14.5 - Operation check with anti-tipping device load



#### ATTENTION

It is mandatory to check the proper operation of the anti-tipping device at the beginning of each work restart.

For a proper check of the device carry out the following operations (fig. 150438-1):

- Place the vehicle on a flat, level surface and engage the parking brake.
- Make sure that the equipment is properly installed on the vehicle and that it is suitable for its capacity.
- Make sure that the anti-tipping device is set for the equipment currently used.
- Perform the test with warm vehicle engine.
- Refer to the load charts of the equipment installed and with closed boom pick up a load approximately weighing 50% of maximum capacity.
- Raise the load at about 50 cm from the ground.
- With the engine idling, extend the boom slowly. During this operation, check the display of the anti-tipping device. When the red zone is reached, the continuous audible signal will operate and the extension movement will stop simultaneously.
- At this point, check that aggravating movements for the equipment assembled are not permitted.
- Check that the stopping occurs at the point indicated in the load chart shown in notebook inside the cab.
- In the event that everything is working properly, it is possible to begin the work.

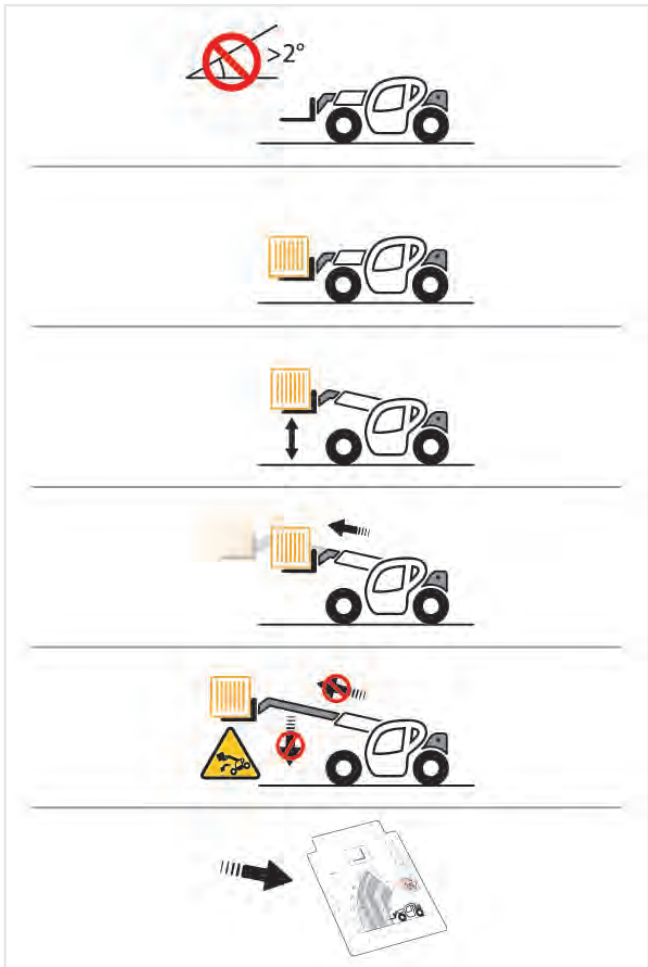

Figure: 150438-1



#### DANGER



**If there are any faults of the safety devices, stop the work until it has been repaired.**

Contact the *Dieci* service centre.

### 7.3.14.6 - Anti-tipping device errors list



#### NOTE

In case the vehicle is in error, contact a *Dieci* service center to solve the problem, indicating the error code reported.

For more information about the errors display, refer to the "Central instrument panel" chapter.

Icon	Example	Description
	000	SAR errors



Error code	Description	Error code	Description
11	CRC error in the memory area that contains the software		<ul style="list-style-type: none"> <li>(Valid only with Vishay cell) CAN-BUS messages receiving time-out</li> </ul>
12	CRC error in the memory area that contains the parameters	39	Load cell A: LIN bus message control meter error
13	Program flow control error	41	Load cell B: CRC error of the load sensor internal parameters
14	Data exchange error between the two micro controls	42	Load cell B: <ul style="list-style-type: none"> <li>Off range signal reading error ( 10 - 990 )</li> <li>With Vishay cell:               <ul style="list-style-type: none"> <li>± 12.55 mV/V</li> <li>Sensor not installed</li> <li>Faulty sensor (power supply or CRC error sensor temperature table)</li> <li>Sensor code not aligned with the supply voltage</li> <li>Faulty A/D converter</li> </ul> </li> </ul>
15	Out of range +7Vdc, +18Vdc power supply voltage error	43	Load cell B: Internal off range offset reading error (526-586)
16	Internal power supply voltage of the first channel out of range 4.8 Vdc, 5.2Vdc error	44	Load cell B: Internal 5Vdc power supply error
17	Internal power supply voltage of the second channel out of range 4.8 Vdc, 5.2Vdc error	45	Load cell B <ul style="list-style-type: none"> <li>Thermal calibration not present error</li> <li>(Valid only with Vishay cell) Temperature reading outside the permitted limits, typically -20° +85°</li> </ul>
21	Cut Off1 output status consistency error	46	Load cell B: LIN bus message check error
22	Cut Off 2 output status consistency error	47	Load cell B: Transmitted data CRC error
23	WDO1 output status consistency error	48	Load cell B: <ul style="list-style-type: none"> <li>LIN bus message receiving error</li> <li>(Valid only with Vishay cell) CAN-BUS messages receiving time-out</li> </ul>
24	Output 1 status consistency error	49	Load cell B: LIN bus message control meter error
25	Output 2 status consistency error	51	Too big difference between the readings of load cells A and B
26	WDO2 output status consistency error	52	Too big difference between load rates detected by channels 1 and 2
31	Load cell A: CRC error of the load sensor internal parameters.	61	Outriggers on the ground double safety input consistency error.
32	Load cell A: <ul style="list-style-type: none"> <li>Off range signal reading error ( 10 - 990 )</li> <li>With Vishay cell:               <ul style="list-style-type: none"> <li>± 12.55 mV/V</li> <li>Sensor not installed</li> <li>Faulty sensor (power supply or CRC error sensor temperature table)</li> <li>Sensor code not aligned with the supply voltage</li> <li>Faulty A/D converter</li> </ul> </li> </ul>	62	Closed boom reading safety double input consistency error
33	Load cell A: Internal off range offset reading error (466-526)	63	Mode selector inputs consistency error
34	Load cell A: Internal 5Vdc power supply error	64	Exclusion key active at the start up error
35	Load cell A <ul style="list-style-type: none"> <li>Thermal calibration not present error</li> <li>(Valid only with Vishay cell) Temperature reading outside the permitted limits, typically -20° +85°</li> </ul>	65	Movements in block reset input active at the start up error.
36	Load cell A: LIN bus message check error	66	Frequency feedback signal reading error
37	Load cell A: Transmitted data CRC error		
38	Load cell A <ul style="list-style-type: none"> <li>LIN bus message receiving error</li> </ul>		

Error code	Description
67	External actuator 1 feedback signal reading error
68	External actuator 2 feedback signal reading error
71	Analog signal from joystick out of range reading signal error
72	Pressure transducer for joystick reset check reading error
73	CAN BUS messages receiving from the optional external unit error
81	Buttons pressed at the start up error
90	Message Counter error (10FF80E3)
91	Message Timeout error (10FF80E3)
92	Message Counter error (18FFF0E3)
93	Message Timeout error (18FFF0E3)
94	SARL response error, different response value
95	Calibration pin not connected any more during the calibration phase
96	Safe Road Traveling Position inconsistency error
97	Internal errors to the panel available
98	Internal errors to the panel available
99	Internal errors to the panel available

## 7.4 - Electrical steering selector

The steering selector (fig. 150312-1) is used to change the wheels steering mode.

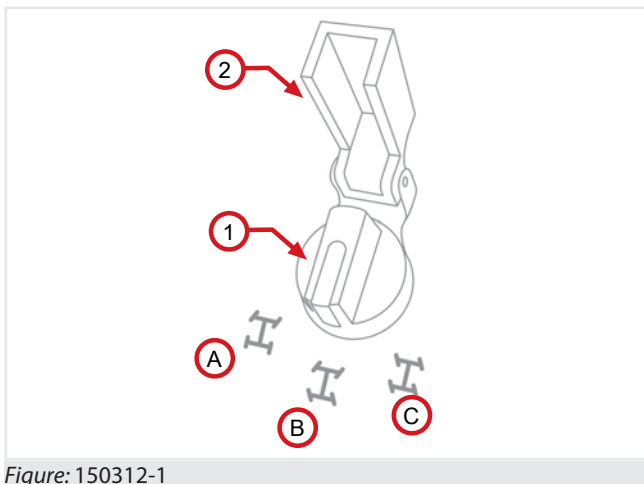

Figure: 150312-1

To select a steering mode, turn the knob "1" that indicates the corresponding symbol:

### A - Front-steering wheels

This type of steering allows to carry out a steering with only the 2 front wheels.

### B - Four-steering wheels

This type of steering allows to carry out the steering with all 4 wheels, so as to have the smallest turning radius possible.

### C - Transverse

This type of steering allows a transverse or crab steering, so as to have a lateral displacement of the vehicle.



## DANGER

**Make the steering selection only with the vehicle stopped.**

Before selecting a new type of steering, align the wheels with stopped vehicle.



## WARNING

When the transverse steering is selected, always operate at low speed.



## ATTENTION

For road travel is mandatory to select the 2-wheel steering mode and lock the selector with the dedicated fastener "2".

## Manual wheel alignment



## ATTENTION

Perform the wheel alignment periodically (every 8-10 hours) depending on the continuous use of the vehicle.

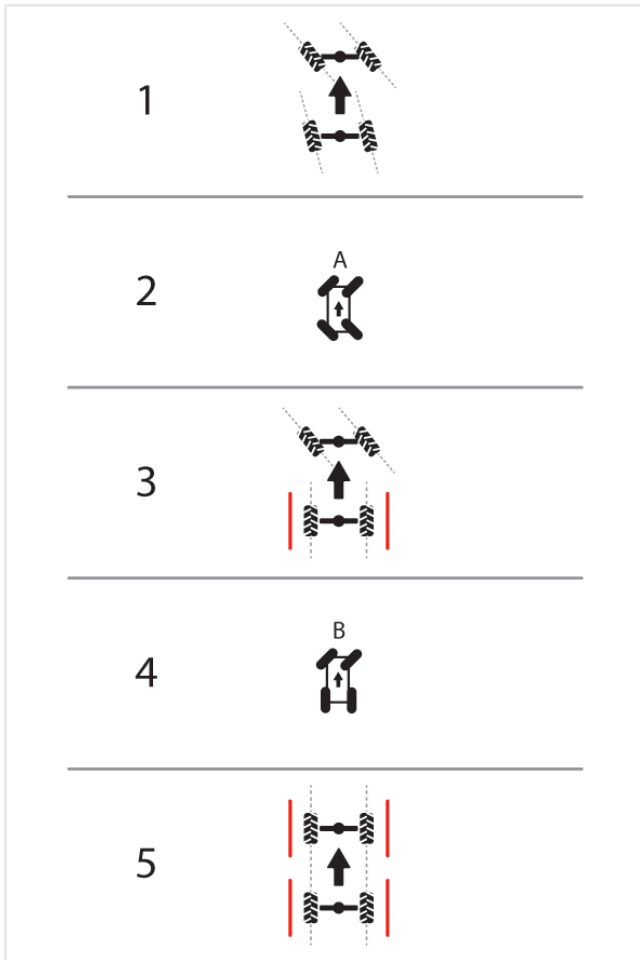

Figure: 150312-2

During normal use of the vehicle, frequently changing the steering modes, it is possible that the wheels are no longer perfectly aligned with each other.

To perform a proper wheel alignment, perform the following steps:

1. Stop the vehicle on a level ground.
2. Select the **B** or **C** steering mode
3. Turn the steering wheel until the rear wheels are aligned to the machine.
4. Select the **A** steering mode
5. Turn the steering wheel until the front wheels are aligned to the machine.
6. Try to move slowly for a few meters to verify that the vehicle travels properly in a straight line.

**If at the end of the alignment the machine still does not proceed in a straight line, repeat the wheels alignment.**

## 7.5 - Automatic wheels alignment \*



### NOTE

The automatic wheels alignment is an optional accessory.



### ATTENTION

Perform the wheel alignment periodically (every 8-10 hours) depending on the continuous use of the vehicle.

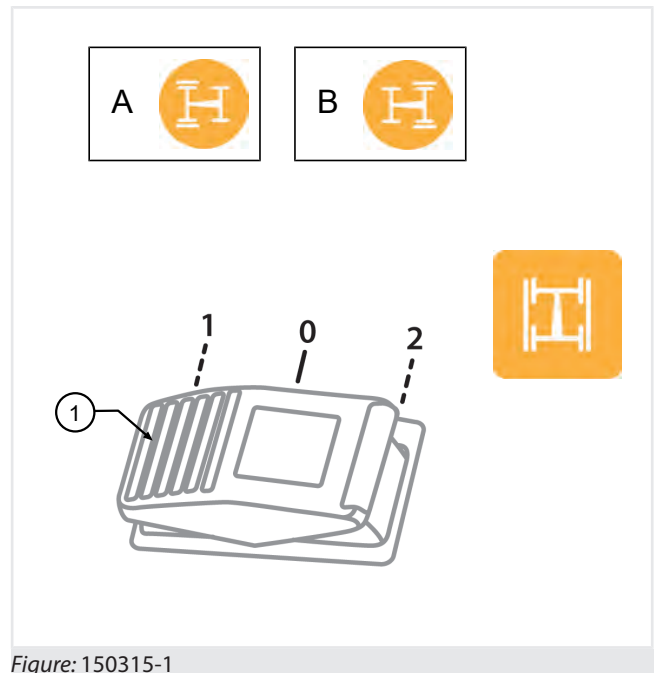

Figure: 150315-1

During normal use of the vehicle, frequently changing the steering modes, it is possible that the wheels are no longer perfectly aligned with each other.

The automatic wheels alignment allows to quickly and accurately align the wheels.

To align the wheels using the automatic wheel alignment, it is necessary to (fig. 150315-1):

1. Stop the vehicle on a level ground.
2. Select the 4-wheel or transverse steering mode.
3. Press the button. After pressing the buttons the indicator lights "A" and "B" will start flashing.
4. Turn the steering wheel to bring the rear wheels aligned to the vehicle, until the indicator light "A" stops flashing.
5. The steering mode is automatically changed to "front steering wheels".
6. Turn the steering wheel to bring the front wheels aligned to the vehicle, until the indicator light "B" stops flashing.

7. The wheel alignment is now completed, the steering wheel will return to the mode originally selected.



**WARNING**

Do not use the vehicle until the alignment procedure has been completed.



**NOTE**

Press the button "1" for more than 3 seconds to activate the display mode. In display mode all the indicator lights "A" and "B" will turn on only if the wheels are aligned to the chassis.

**7.6 - Joystick**

**7.6.1 - Joystick with capacitive deadman sensor**

The Joystick allows you to operate all the telescopic boom movements.

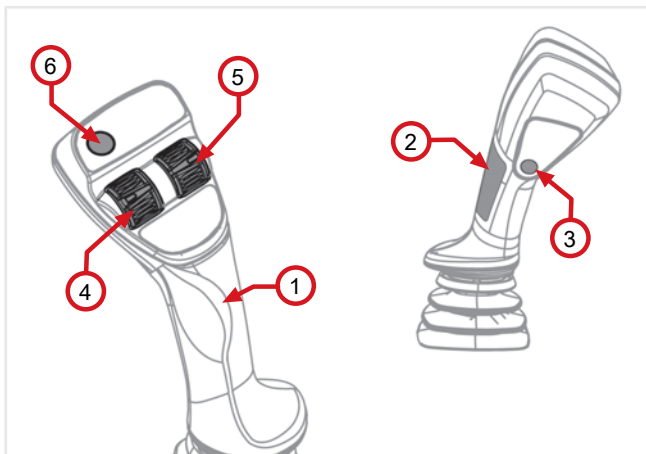

Figure: 150450-1

It consists of (fig. 150450-1):

1 Grip	2 Capacitive sensor
3 Deadman button	4 Extension/retraction roller
5 Services roller	6 Continuous oil function button **

\*\* Components depending on optional equipment or pre-arrangements.



**ATTENTION**

**The deadman joystick function prevents any accidental movements of the boom.**

The Joystick features a "deadman" capacitive sensor: to enable it to function you need to place your hand on the grip "1" correctly so as to activate the capacitive sensor "2".

If your hand is not resting on the capacitive sensor "2", boom movements are disabled.



**WARNING**

Before operating the boom, make sure that the area around the vehicle is clear.

Make sure that the loads to be lifted are included in the vehicle load charts.

Adjust the seat so you can hold the joystick correctly (fig. 150450-2).

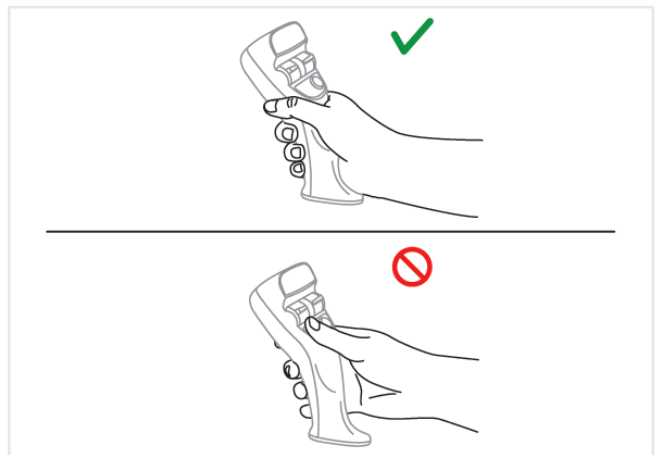

Figure: 150450-2

It is possible to use the deadman button "3" if the sensor "2" fails to work properly.

Unless you hold the joystick correctly or press the deadman button, all the joystick functions are disabled.

The movements that are possible using the joystick are:

CONTROL	MOVEMENT	
Grip forwards	Boom lower	
Grip backwards	Boom up	
Grip to the left	Tilting upwards	
Grip to the right	Tilting downwards	

CONTROL	MOVEMENT	
Extension/ retraction roller forwards	Boom extension	
Extension/ retraction roller backwards	Boom retraction	
Services roller forwards	Oil to the hydraulic socket selected (colour <b>blue</b> or sign "+")	
Services roller backwards	Oil to the hydraulic socket selected (colour <b>red</b> or sign "-")	



**NOTE**

The joystick controls correspond to proportional movements of the vehicle.

**7.6.2 - Joystick for man basket prearrangement**

Joystick with standard mechanical deadman button.

The Joystick allows you to operate all the telescopic boom movements.

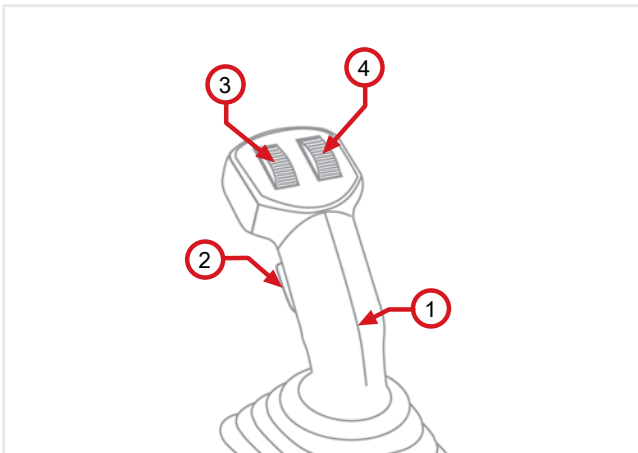

Figure: 150452-1

It consists of (fig. 150452-1):

1 Grip	2 "Deadman" button
3 Extension/retraction roller	4 Services roller



**ATTENTION**

**The deadman joystick function prevents any accidental movements of the boom.**

The Joystick is with mechanical "deadman" sensor: to enable its operation it is necessary to hold down the deadman button "2" on the joystick grip for the duration of the operation.

Without pressing the Deadman button, all joystick functions are disabled.



**WARNING**

Before operating the boom, make sure that the area around the vehicle is clear.

Make sure that the loads to be lifted are included in the vehicle load charts.

The movements that are possible using the joystick are:

CONTROL	MOVEMENT	
Grip forwards	Boom lower	
Grip backwards	Boom up	
Grip to the left	Tilt upwards	
Grip to the right	Tilt downwards	
Extension/ retraction roller forwards	Boom extension	
Extension/ retraction roller backwards	Boom retraction	
Services roller forwards	Oil to the hydraulic socket selected (color <b>blue</b> or sign "+")	
Services roller backwards	Oil to the hydraulic socket selected (color <b>red</b> or sign "-")	



**NOTE**

The joystick controls correspond to proportional movements of the vehicle.

### 7.6.3 - Joystick error list



#### NOTE

In case the vehicle is in error, contact a **Dieci** service center to solve the problem, indicating the error code reported.

For more information about the errors display, refer to the "Central instrument panel" chapter.

Icon	Example	Description
	000.E4	Joystick errors

CODE	COMPONENT	ALARM
006.E4		Power supply voltage 5V low with Engine ON
007.E4		Power supply voltage 5V high with Engine ON
010.E4	SAR	Invalid input voltage
011.E4		Invalid input voltage
015.E4		SLOW MOTION signal inconsistent with the active SAR alarm Pre-Alarm not active
016.E4		SAR alarm active
017.E4		SLOW MOTION pre -alarm active
018.E4		Inconsistency between 2 CUT OFF signals
025.E4	Hand Throttle	One of the 2 switches pressed or broken at the ENGINE START
026.E4		Pressed simultaneously
030.E4	Pedal Throttle	Redundancy control out of tolerance
031.E4		At least one signal out of range
041.E4	Swiveling Rod Microswitch	ENGINE START with mechanical lever not released or broken microswitch
050.E4	FNR	Invalid input voltage
090.E4	Power supply +5Vdc	Output voltage lower than the lower limit of operation of the Joystick and of the rotation sensor (Control Unit Malfunction)
091.E4		Output voltage higher than the upper limit of operation of the Joystick and of the rotation sensor (Control Unit Malfunction)
101.E4	SWITCH JOYSTICK	ENGINE START with deadman switch not released or broken

CODE	COMPONENT	ALARM
110.E4	Roller JOYSTICK	Redundancy control out of tolerance
111.E4		At least one signal out of range
114.E4		Redundancy control out of tolerance
115.E4		At least one signal out of range
118.E4		Redundancy control out of tolerance
119.E4		At least one signal out of range
140.E4	Low Idle Up solenoid valve	Output not commanded but a too high current consumption has been detected
141.E4		Output commanded but a too low current consumption has been detected
142.E4		Output commanded but a too high current consumption or a short circuit have been detected
145.E4		Button pressed during the engine starting
150.E4	Solenoid valve Distributor	Not commanded but a current consumption exceeding the threshold has been detected (Control Unit Malfunction)
151.E4		Commanded but the control unit does not detect a current consumption exceeding the threshold (Control Unit or Distributor Malfunction)
152.E4		Output commanded but the control unit detects a high consumption (Control Unit or Distributor Malfunction)
160.E4	Solenoid valve Servo control	Not commanded but a current consumption exceeding the threshold has been detected (Control Unit Malfunction)
161.E4		Commanded but the control unit does not detect a current consumption exceeding the threshold (Control Unit or Distributor Malfunction)
162.E4		Output commanded but the control unit detects a high consumption (Control Unit or Distributor Malfunction)



CODE	COMPONENT	ALARM
170.E4	Forward Command	Not commanded but a current consumption exceeding the threshold has been detected (Control Unit Malfunction)
172.E4		Output commanded but the control unit detects a high consumption (Control Unit or Distributor Malfunction)
180.E4	Reserve Command	Not commanded but a current consumption exceeding the threshold has been detected (Control Unit Malfunction)
182.E4		Output commanded but the control unit detects a high consumption (Control Unit or Distributor Malfunction)
190.E4	Transmission Disconnect Command	Not commanded but a current consumption exceeding the threshold has been detected (Control Unit Malfunction)
192.E4		Output commanded but the control unit detects a high consumption (Control Unit or Distributor Malfunction)
200.E4	Extension OUT distributor solenoid valve command	Not commanded but a current consumption exceeding the threshold has been detected (Control Unit Malfunction)
201.E4		Commanded but the control unit does not detect a current consumption exceeding the threshold (Control Unit or Distributor Malfunction)
202.E4		Output commanded but the control unit detects a high consumption (Control Unit or Distributor Malfunction)
210.E4	Extension IN distributor solenoid valve command	Not commanded but a current consumption exceeding the threshold has been detected (Control Unit Malfunction)
211.E4		Commanded but the control unit does not detect a current consumption exceeding the threshold (Control Unit or Distributor Malfunction)

CODE	COMPONENT	ALARM
212.E4		Output commanded but the control unit detects a high consumption (Control Unit or Distributor Malfunction)
220.E4		Auxiliary distributor A solenoid valve command
221.E4		Commanded but the control unit does not detect a current consumption exceeding the threshold (Control Unit or Distributor Malfunction)
222.E4		Output commanded but the control unit detects a high consumption (Control Unit or Distributor Malfunction)
230.E4	Auxiliary distributor B solenoid valve command	Not commanded but a current consumption exceeding the threshold has been detected (Control Unit Malfunction)
231.E4		Commanded but the control unit does not detect a current consumption exceeding the threshold (Control Unit or Distributor Malfunction)
232.E4		Output commanded but the control unit detects a high consumption (Control Unit or Distributor Malfunction)
240.E4	Hydraulic power function	Output not commanded but a too high current consumption has been detected
242.E4		Output commanded but an anomalous current consumption or a short circuit have been detected

## 7.7 - Hydraulic sockets and electrical contact on boom head \*



### NOTE

\* The presence and number of hydraulic sockets and electrical contacts present on the boom head may vary depending on optional equipment.



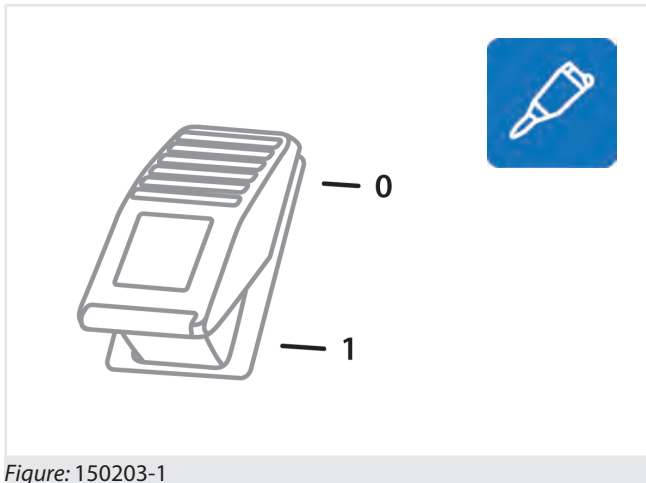

Figure: 150203-1

The sockets switch on the boom head (fig. 150203-1) has several functions and positions depending on the optional attachments installed on the vehicle.

Once selected the desired hydraulic socket, it is necessary to use the services lever on the joystick to operate the desired movement.



**DANGER**

**Danger of moving the wrong hydraulic socket.**

Do not operate the hydraulic sockets using the joystick during the selection of the hydraulic socket. Make the selection of the hydraulic socket and use the joystick to control the hydraulic socket selected only at a later time.

After connecting the equipment to the hydraulic sockets before starting the job, check in a safe location that all the controls are working properly. During the test, be careful not to create danger or damage to persons, animals or things.



**WARNING**

Pay attention to the connections of the hydraulic socket: moving the service lever placed on the joystick forward, towards the open padlock (see Joystick chapter), will send oil to the sockets marked with the colour **BLUE** or by the symbol "+".

Attachments	Diagram	Switch description
Standard hydraulic socket		0 - Electrical contact off
+ Electrical contact		1 - Electrical contact on

Attachments	Diagram	Switch description
Standard hydraulic socket		0 - Standard hydraulic socket
+ Additional hydraulic socket		1 - Electrical contact on
+ Electrical contact		2 - Additional hydraulic socket

**7.8 - Electrical contact on boom head \***



**NOTE**

\* The electrical contact on the boom head is an optional accessory.

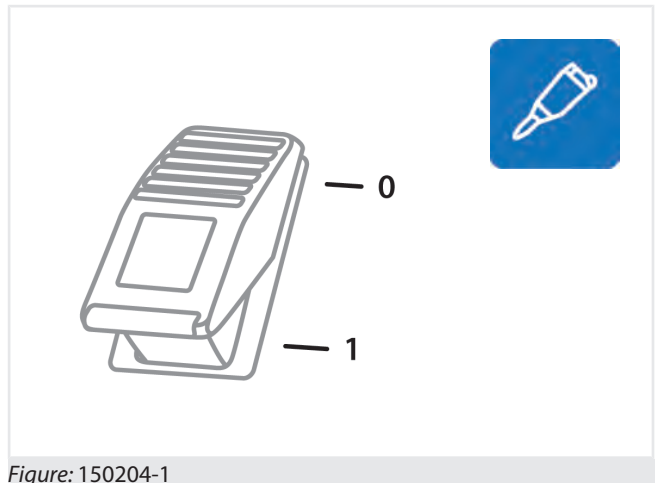

Figure: 150204-1

At the socket of the electric contact on the telescopic boom head (fig. 150204-1) it is possible to connect:

- The plug of the solenoid valve of the Second Additional hydraulic socket
- The plug of any equipment installed on the attachment holding plate.

To activate the electric contact, place the Sockets switch on the boom head in position "1" - See table in the previous chapter.



**NOTE**

For information on how to make the connections to the electrical socket, refer to the "Electrical connections" chapter.



**WARNING**

**Do not connect users with nominal voltage greater than 12 V and amperage greater than 3 A.**

Risk of damage to the electrical system.



**DANGER**

Do not operate without having properly secured the equipment to the plate, danger of load and equipment falling.

**7.9 - Equipment quick coupling \***



**NOTE**

\* The equipment quick coupling is an optional accessory.

The equipment quick coupling allows the operator to install and fasten the equipment to the attachment holding plate directly from the cab.

There are different models of quick couplings for equipment, they can be with a single block cylinder lock or double block cylinder, the procedures for use change according to the type of hydraulic system of the vehicle.

**7.9.1 - Quick coupling with single lock on open circuit vehicle**

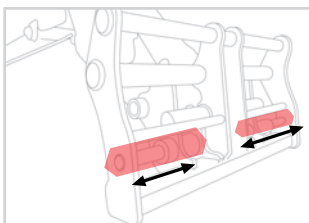

150206-4

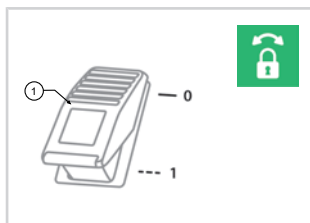

150206-5

To use the quick coupling (fig. 150206-4) for the equipment installation it is necessary to:

- Carry out the normal hooking operations set out in paragraphs 1, 2, 3 and 4 of the chapter "Equipment installation procedure".
- Press the Quick Coupling button "1" (fig. 150206-5) and at the same time operate the roller on the services joystick to open the quick coupling.
- Tilt the plate upward to make sure that the equipment is fully resting on the attachment holder plate.
- Press button "1" and the roller to close the quick coupling and lock the equipment.
- If the equipment is not properly fastened, repeat the installation.

**7.10 - Safety rod**

The safety rod must be used as a safety measure during maintenance operations, to prevent the descent or fall of the boom in case of failures.

To insert the safety rod "1" (fig. 150459-1) operate as follows:

- Lay a load on the ground
- Completely close the extensions of the telescopic boom
- Lift the boom to the minimum height necessary to apply the safety rod
- Apply the safety rod around the lifting cylinder rod

Lock the safety rod by means of the appropriate hooks "2".

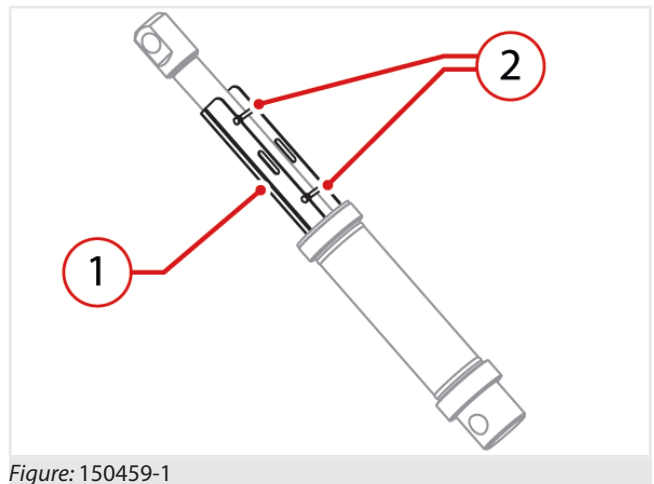

Figure: 150459-1



**WARNING**

**DANGER OF CRUSHING**

In case of maintenance to the boom lifting cylinder or the relative block valve it is required to support the boom by means of an appropriate lifting device with minimum capacity of at least 3000 kg (6613.87 lb).

## 7.11 - Wheel wedge

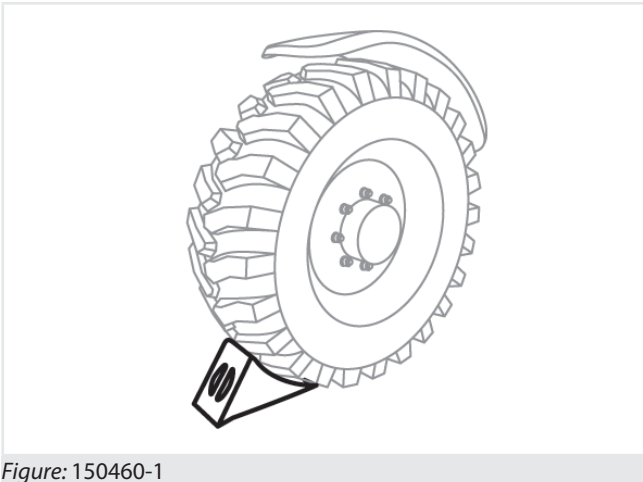

Figure: 150460-1

The wheel wedge (fig. 150460-1) must be used as a safety measure to prevent accidental or unwanted movements of the vehicle.

It is advisable to use them when parking the vehicle during stops along slopes or during maintenance operations.

## 7.12 - Block valves

The block valves (fig. 150461-1) for cylinders prevent uncontrolled movement of the pistons of the cylinders in the event of hydraulic pressure failure or bursting of a flexible pipe.

The valves are installed directly on all the cylinders.

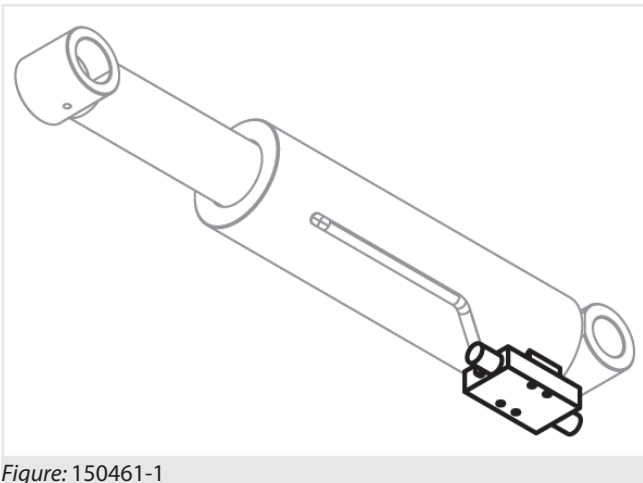

Figure: 150461-1

## 7.13 - Diagrams notebook

The diagrams notebook (fig. 150462-1) summarizes the main information for safe use of the vehicle for easy reference by the operator during the various processing phases.

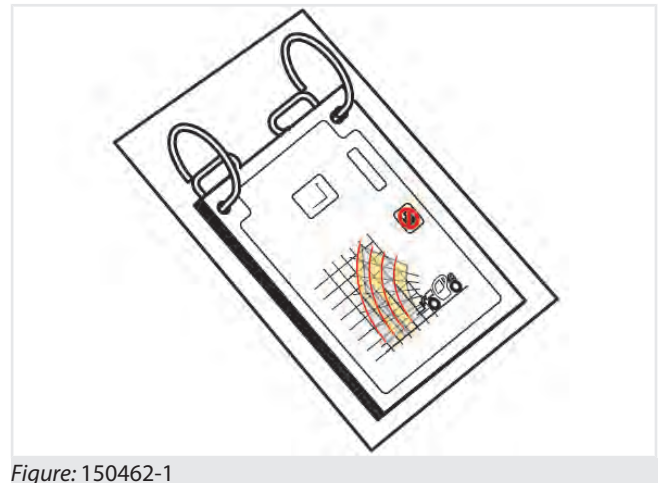

Figure: 150462-1

### 7.13.1 - Load Charts

The Safe Working Load (SWL) of the vehicles depends on the extension extent and the boom angle.

The load charts show the maximum height and extent allowed by certain equipment and loads, in order to work safely, without the risk of tipping of the vehicle during work operations.

This vehicle is however equipped with an anti-tipping device that monitors in real time the status of the load and the risk of tipping of the vehicle (see the "Anti-tipping device" chapter in the vehicle manual). It is however necessary to use and adhere to the load charts in relation to the load and type of accessory used.



#### ATTENTION

**It is mandatory to have in the cab, the load chart referred to the equipment and the vehicle that is being used.**

Refer to the correct load chart before handling a load.



#### DANGER

**Danger of tipping.**

Do not raise or extend the boom when the vehicle is in motion. Fully lower and retract the boom before moving a load.



#### ATTENTION

The load charts refer to stopped and levelled vehicle.



**ATTENTION**

The diagrams of the vehicle and equipment being used must always be present in the Diagram notebook found in the cab, used by the operator.

Replace the load charts if they deteriorate, are damaged or lost.

The load charts are ordered just like spare parts (make sure you provide the relative identification code when placing the order).

Before handling a load it is necessary to:

- Have read and understood the use and maintenance manual of the vehicle and equipment.
- It is mandatory to know the weight of the load that must be handled.
- Locate the centre of gravity of the load to be handled. The centre of gravity may not be at the centre of the load.

**7.13.1.1 - Read the load charts**

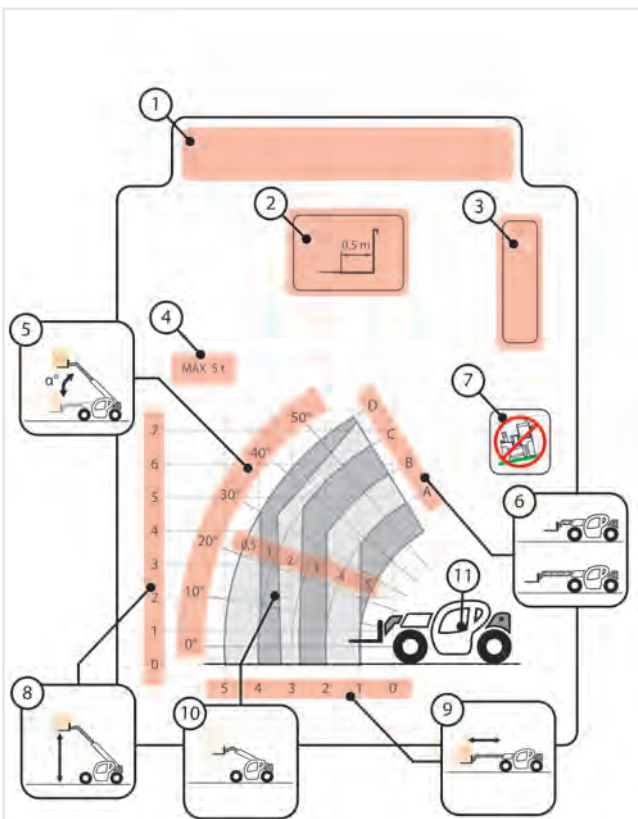

Figure: 150464-1 - Load Chart

1	<b>Vehicle name and model</b>
2	<b>Equipment model</b> Equipment model with the indications of centre of the load.

	For more information, see chapter Equipment legend for load charts [▶ 109].
3	<b>Load Chart code</b>
4	<b>Equipment maximum capacity</b> The maximum capacity of the equipment is also reported by the sticker placed on the equipment itself.
5	<b>Boom angle</b> The boom angle is indicated by the inclinometer on the left side at the end of the boom (if any), or on the display of the anti-tipping device (if present).
6	<b>Boom extension</b> The boom extension is indicated by letters of the alphabet ("A", "B", "C", "D", etc...). The same letters are shown as stickers on the boom extension, so that the user in the cab can know the boom extension by reading the letters on it.
7	<b>Vehicle operating mode</b> For more information, see chapter Operating modes legend for load charts [▶ 109].
8	<b>Load height from ground</b>
9	<b>Horizontal distance of the vehicle load</b>
10	<b>Load weight</b>
11	<b>Vehicle position</b>

**7.13.1.2 - Use the load charts**

The Load charts indicate the areas in which it is possible to operate with the vehicle and load in safe conditions.



**DANGER**



**Danger of tipping.**

Operating the vehicle without observing the Load charts related to the equipment installed may result in hazardous conditions, up to the tipping limit and the operation of the Anti-tipping device.

The whole working area of the boom is divided into these areas (position "1", fig. 150465-1). Each area corresponds to a maximum capacity. The area closest to the vehicle will have a capacity equal to the maximum loading capacity of the vehicle; as moving away from the vehicle, the maximum capacity of the areas decreases.

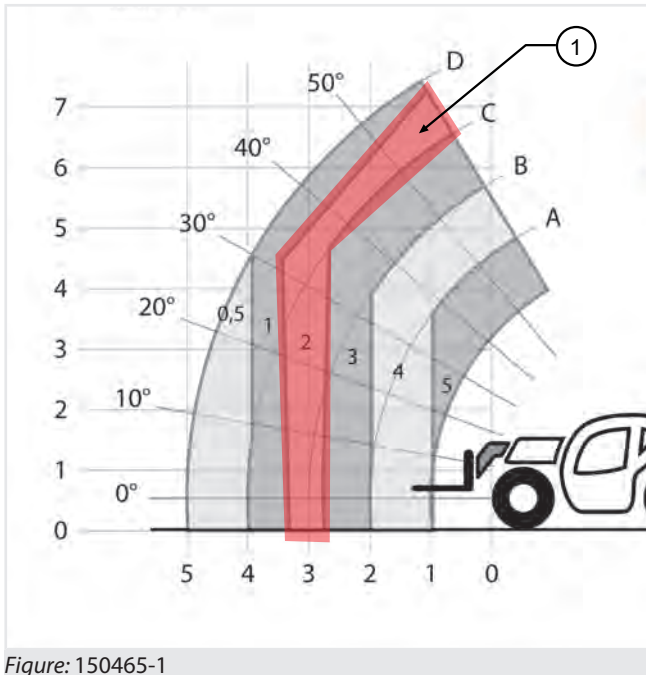

Figure: 150465-1

Before starting to work, it is necessary to know:

- Load weight
- Height from ground at which the load must be handled
- Distance from the vehicle at which the load must be handled

Locate the area of the load charts, showing a value just above the weight of the load to be handled; for example if the load should weigh 1.5 tons, the area to which it is necessary to refer is the area with a capacity of 2 tons (position "1").

Knowing the area, the following will be known:

- the vertical and horizontal distance to which it will be possible to handle the load
- the boom extension and angle values at which it is possible to operate.

In order to know the vertical and horizontal distance to which it will be possible to handle the load, use the horizontal and vertical lines that cross the reference area; for example, it will be possible to carry the load at a distance of 3 m from the vehicle and 4 m in height remaining in safety conditions (position "2", fig. 150465-2).

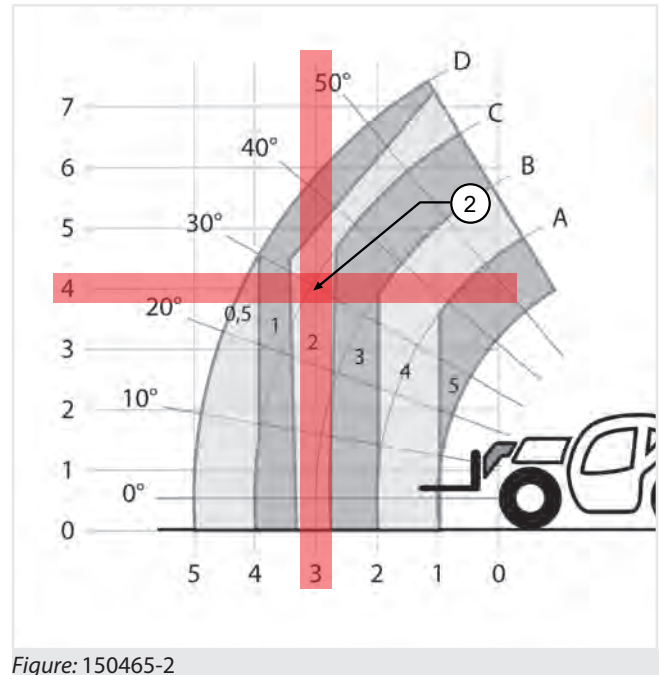

Figure: 150465-2

To avoid operating in conditions of tipping danger, use the boom angle and extension indications. For example, we could operate with the boom extended to letter C at an angle of 30° (position "3", fig. 150465-3).

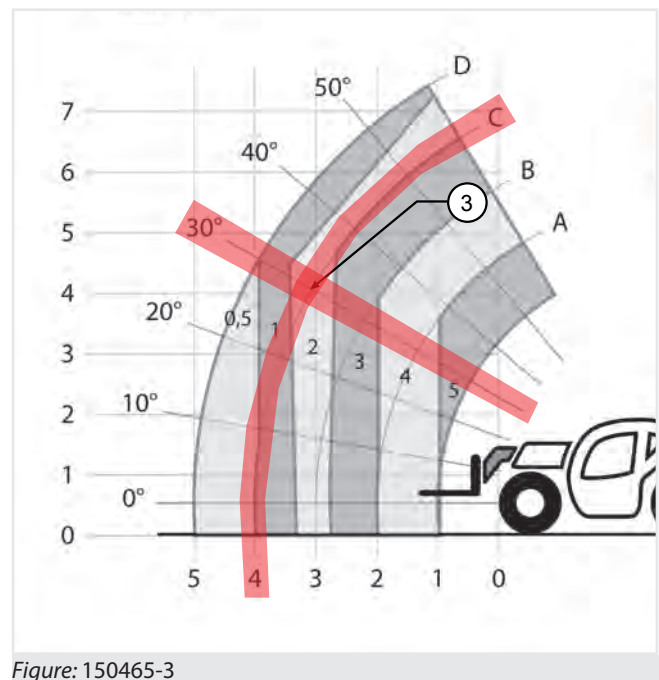

Figure: 150465-3





**DANGER**



**Taking the load beyond the permissible area, we would enter in danger conditions of tipping over and the anti-tipping device, locking all the movements considered aggravating to the stability of the vehicle and of the load.**

Use the load charts for each load handling to determine the working area.

It is possible to start operating only under safety conditions and if within the predetermined safe work area.

**7.13.1.3 - Equipment legend for load charts**

	Forks xxx = Centre of gravity of the load
	Forks Spreader / Shifter xxx = Centre of gravity of the load
	Winch xxx = Capacity
	Crane extension xxx = Centre of gravity of the load
	"Gooseneck" jib (Dimensions) xxx = Centre of gravity of the load
	Hook for fork carrier plate
	Gripper for pipe with pipe locker xxx = Centre of gravity of the load
	Cylinders manipulating gripper
	Wheels manipulating gripper
	Sheets holding gripper
	5 teeth orange-peel grabber

	Centring layer
	Negative jib
	Positive jib
	Fixed front basket xxx = length, yyy = width
	Extensible front basket xxx = length, yyy = width, zzz = maximum width
	Fixed trilateral basket xxx = length, yyy = width
	Extensible trilateral basket xxx = length, yyy = width, zzz = maximum width
	Front basket for tunnels xxx = length, yyy = width
	Fixed trilateral basket for tunnels xxx = length, yyy = width

**7.13.1.4 - Operating modes legend for load charts**

	Prohibition to operate on tyres
	Prohibition of operating with unlevelled vehicle
	Crossbeam outriggers lowered, 0% extended
	Crossbeam outriggers lowered, 50% extended
	Crossbeam outriggers lowered, 100% extended
	Crossbeam outriggers lifted
	Flap down outriggers lifted

	Flap down outriggers lowered
	On wheels
	Front position
	In non-continuous Rotation
	In continuous Rotation

## 7.14 - Water heater \*



### NOTE

The Water heater is an optional accessory.

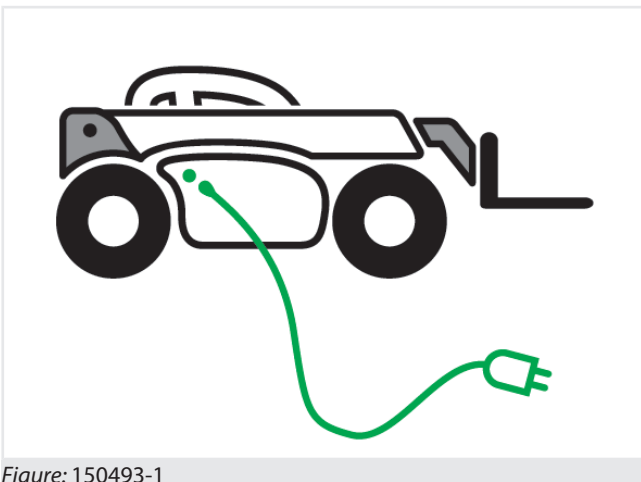

Figure: 150493-1

The water heater is connected to its own control unit and is used to facilitate the ignition of the engine in the winter period or in case of cold climates.

The water heater is placed in the rear side of the hood.

To use the water heater it is necessary to:

- Make sure the vehicle is off.
- Enter the extension in the socket at the rear of the hood.
- Enter the extension in the **220 V** socket.
- Wait until the water is adequately heated.
- Remove the water heater extension from the socket and from the socket on the hood.



### DANGER

Do not use the water heater with the engine running or the machine in travel.



### WARNING

**Remove the water heater power connections before turning on and/or moving the machine.**

Check the good condition of the power cord before starting up the device.



### NOTE

In case of malfunction contact the *Dieci* service center.

## 7.15 - Transmission

### 7.15.1 - Movement selection lever \*



### NOTE

**The movement selection levers are an optional equipment.**

FNR movement levers can be of two types:

- Stay-put control lever.
- Spring-return control lever.

#### Stay-put control lever



### ATTENTION

In order to select a direction of movement, it is necessary to move the movement selection lever towards the steering wheel. This shifting protects the lever from accidental operation.

With the movement selection lever in position other than "N", it is not possible to start the engine.

The Movement selection lever, at the left of the steering wheel, allows setting the direction of travel of the machine.

- Pull the lever towards the steering wheel and push it forward ("F" direction) to proceed forward.
- Pull the lever towards the steering wheel and pull it back ("R" direction) to proceed in reverse. When driving in reverse, an alarm sounds intermittently.



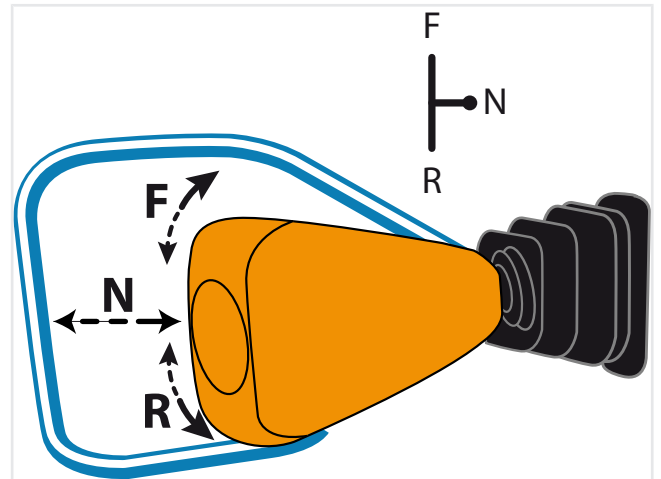
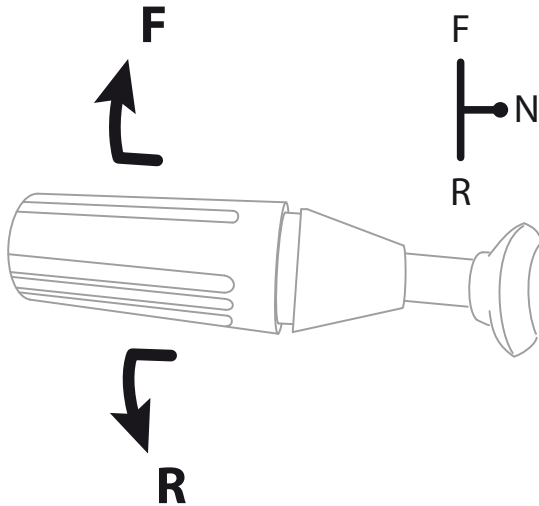

While holding the lever in an intermediate position "N" the transmission is in neutral and the vehicle is partially braked.

With the forward/reverse movement gear selection lever in position other than "N", the engine will not start.



After selecting a direction of movement, the corresponding indicator lights on the instrument panel turn on:

	"F" forward movement
	"R" reverse movement

**Spring-return control lever**



**ATTENTION**

With the movement selection lever in position other than "N", it is not possible to start the engine.

The Movement selection lever, at the left of the steering wheel, allows setting the direction of travel of the machine.

- Move the lever upward ("F" direction) to travel forward.
- Move the lever downwards ("R" direction) to proceed in reverse. When driving in reverse, an alarm sounds intermittently.
- Move the lever toward the steering wheel ("N" position), the transmission is in neutral and the vehicle is partially braked.



**NOTE**

**Once the direction has been selected, the spring inside the lever will return it to its central position while maintaining the desired direction.**

The movements of the lever are not active when:

- The handbrake is engaged
- The operator is not properly seated in the driver's seat



**NOTE**

**If the operator is not sitting properly in the driver's seat, the transmission is automatically switched off.**



**WARNING**

**After selecting the vehicle movement direction, it starts suddenly to move in the selected direction.**

Before selecting the movement direction make sure that nobody is standing near the vehicle.



## WARNING

It is dangerous to operate the movement selection lever with the engine at high rpm or at a speed higher than 2 km/h (1.2 mph).

Before reversing the direction of movement, minimize the engine speed and select the new direction. Danger of vehicle overturning severe breakage of mechanical parts.



## NOTE

Shift the first gear to operate on the work site.

Shift the second gear for long trips with no load, at clear work sites, with good visibility, in the absence of obstacles, with consistent and level ground floor, without transit of people.



## WARNING

Never try to shift gears with the vehicle in motion.



## NOTE

The "1" and "2" gear selection on the movement selection lever is not active.

### 7.15.2 - Manual gear shift selection

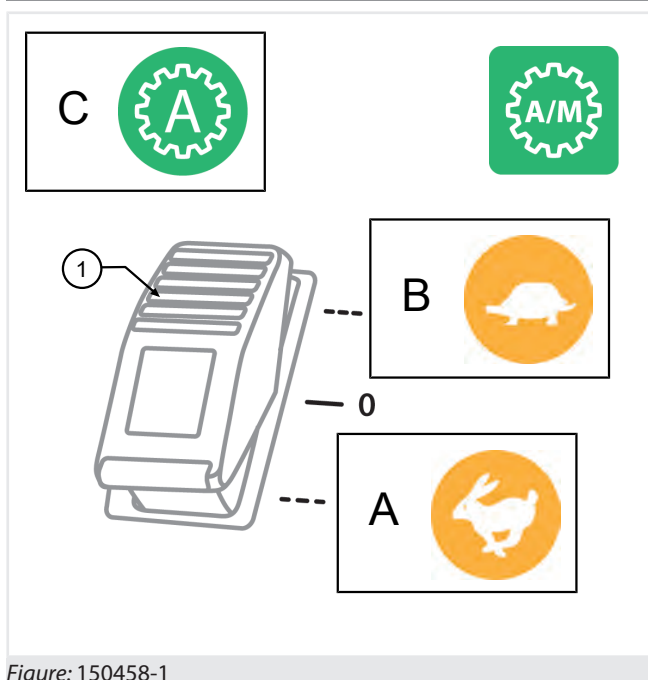

Figure: 150458-1

The "1" button (fig. 150458-1) allows changing the manual gear shift.

#### To change the manual gear shift:

- Stop the vehicle completely.
- Press the inching and brake pedals and hold.
- Press "1" for a few seconds:
- Down to shift the **Fast** gear, the indicator light "A" on the instrument panel turns on to indicate its selection.
- Up to shift the **Slow** gear, the illumination of the "B" on the instrument panel turns on to indicate its selection.
- Wait that the related indicator light turns on.
- Release the inching and brake pedals.
- Drive slowly and gradually to allow the gear to fit properly. The indicator light "C" indicates the gear properly shifted.

### 7.15.3 - Service braking pedal

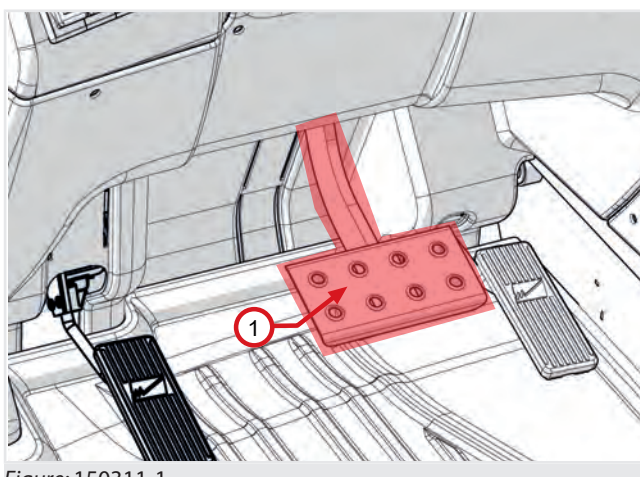

Figure: 150311-1

Press the service brake pedal "1" (fig. 150311-1) to slow down or stop the vehicle.

The pedal acts directly on the service brakes inside the differential axles.

When the brake pedal is pressed the stop lights of the rear lights go on. The lights remain in operation until the pedal is released.

Periodically check that both lights are working.



150311-2



## WARNING

In the case of restricted use of the pedal periodically check its proper operation. In case of problems contact the *Dieci* service center.



**DANGER**

If the warning light (fig. 150311-2) turns on intermittently, it indicates a low brake fluid level.  
 If the warning light (fig. 150311-2) turns on in a fixed way, the parking brake is stuck or damaged.  
 Do not use the vehicle until the problem has been solved. Contact a *Dieci* service center.

**7.15.4 - Inching Pedal**

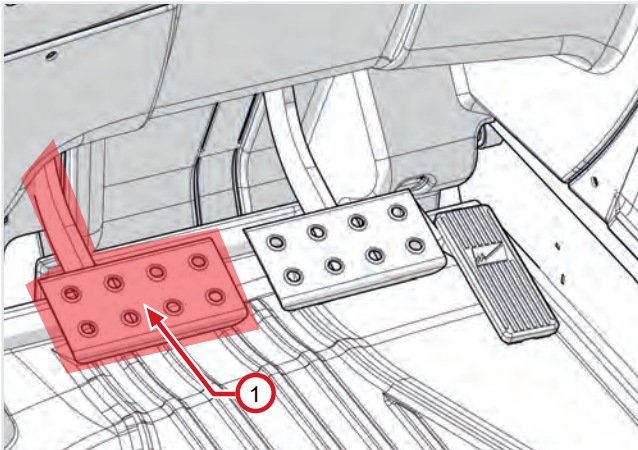

Figure: 150740-1

The inching pedal "1" (fig. 150740-1) acts directly on the hydrostatic transmission and allows to slow down the vehicle forward movement.

The pedal allows slow and precise forward movements with high rpm heat engine.

With pedal fully pressed, the vehicle stops the forward movement.



**DANGER**

Do not press the inching pedal at high speeds, the vehicle brakes suddenly and the diesel engine risks over-revving.

**7.15.5 - Accelerator pedal**

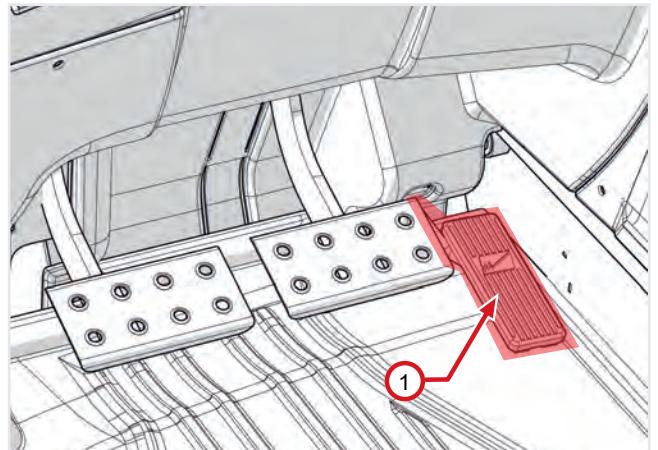

Figure: 150741-1

Press the accelerator pedal "1" (fig. 150741-1) to increase the engine speed, when the pedal is released the engine rpm will decrease.

The pedal acts directly on the injection pump of the engine.



**WARNING**

**If while driving, the vehicle exceeds the maximum allowed speed, the "Over speed protection" transmission electronic control goes into operation. The function automatically limits the vehicle speed in order to prevent transmission and diesel over revving. Triggering of the "Over speed protection" function is signaled by the general alarm indicator light switching on and the intermittent acoustic signal.**

If the function intervenes, the operator must lift his foot from the accelerator pedal and reduce the speed of the vehicle.



**NOTE**

The maximum speed of the vehicle varies with the inflation pressure and the size and wear of the tires.

### 7.15.6 - Manually disable off the 2-gear hydrostatic transmission



#### DANGER

Deactivate the traction only in case it is necessary to tow the vehicle in case of damage to the engine and/or transmission.

In case it is necessary to tow the machine with the engine and/or transmission failure, it is possible to manually disable the transmission.

Carry out the following operations:

- Make sure that the vehicle engine is turned off
- Place chocks under the wheels to prevent sudden movements of the vehicle
- Turn the lever of the hydraulic valve (fig. 150745-1), to turn off the hydraulic supply to the reduction gear (the valve is located under the vehicle, near the reduction gear).

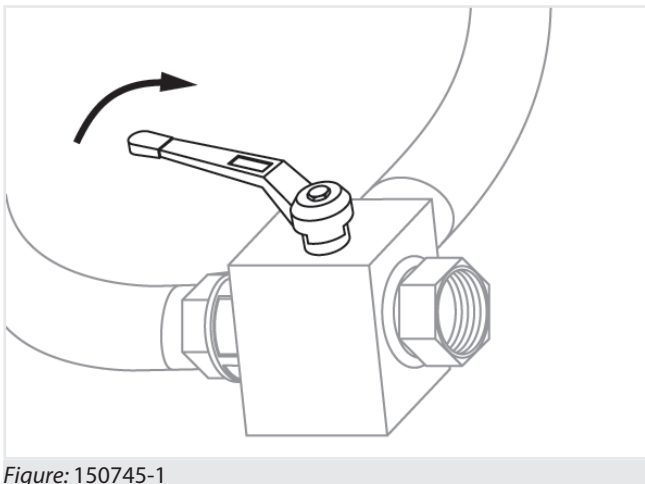

Figure: 150745-1

**DANGER! Rotating the handle a jet of oil under pressure may leak out from the valve. Use appropriate safety equipment to protect eyes and skin from hot oil under pressure.**

- Using a screwdriver, move the gear selection pin in neutral, at half stroke "2" (fig. 150745-2)
- If possible, before towing the vehicle turn on the instrument panel and check that the indicator lights of the forward and reverse gear are off.

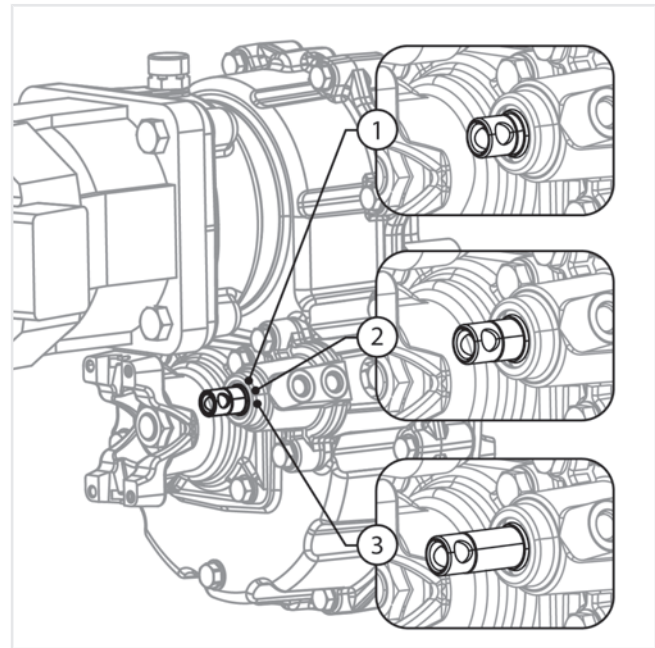

Figure: 150745-2



#### ATTENTION

Once the towing operations are completed open the valve again returning the lever (fig. 150745-1) to the starting position.



**7.16 - Remote Control \***



**NOTE**

\* The Remote control is an optional accessory.

**7.16.1 - Remote Control: Description**

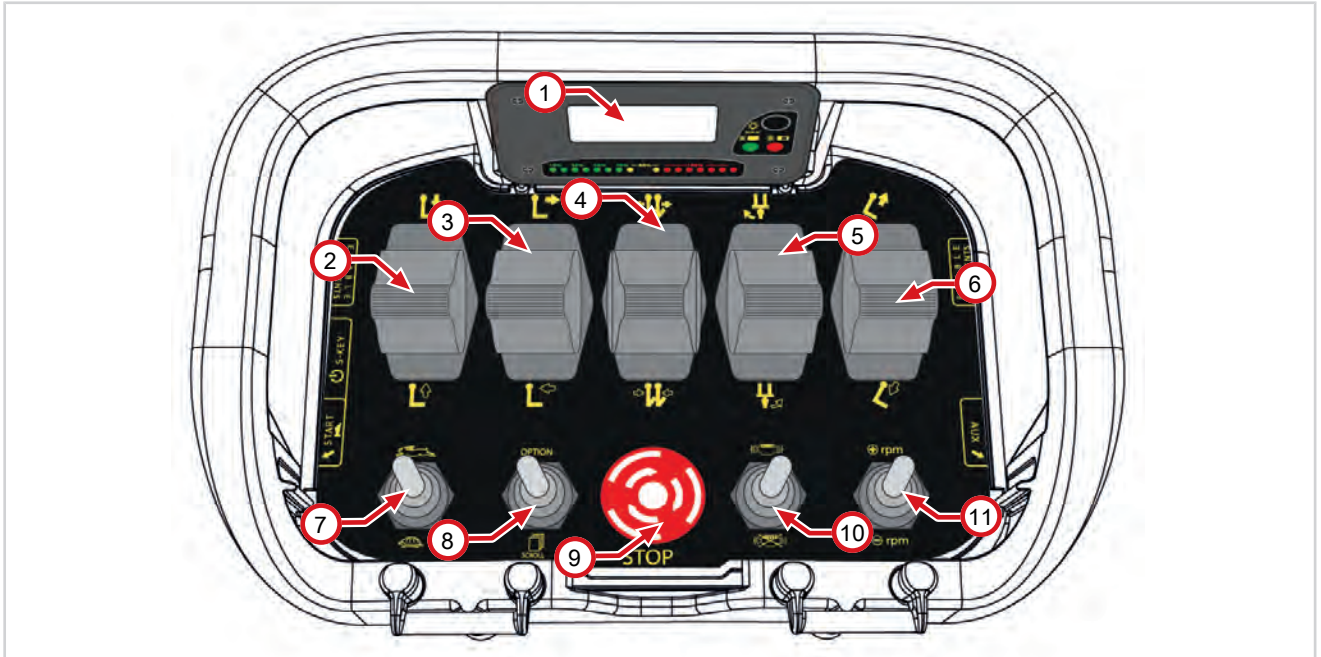

Fig. 160601-1

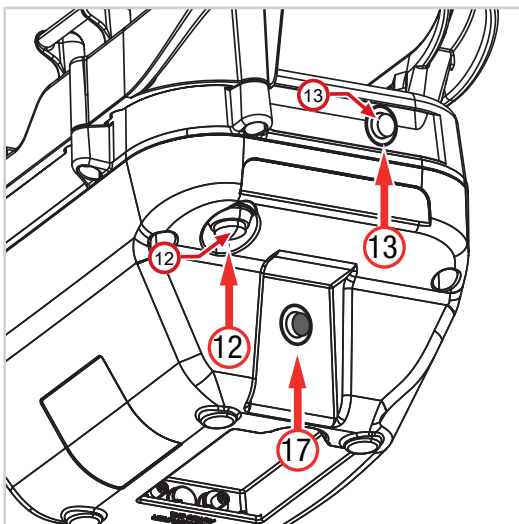

Fig. 160601-2

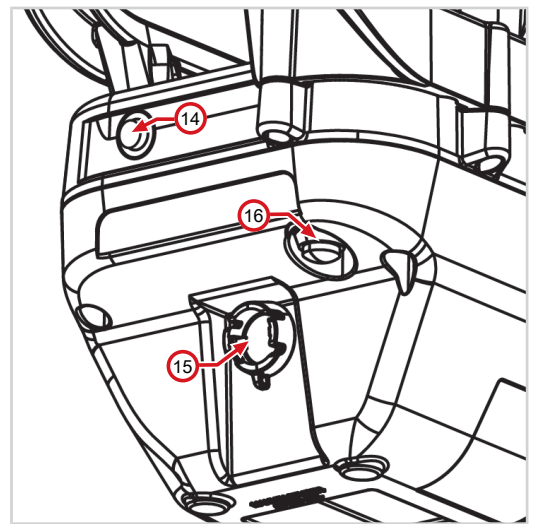

Fig. 160601-3

1	LCD display	9	Emergency stop button
2	Boom up /down lever	10	Vehicle ignition switch
3	Boom extension / retraction lever	11	Accelerator lever
4	Services lever	12	Boom head electrical contact button
5	Turret rotation lever (for rotating vehicles)	13	Not used

6	Up / down tilting lever	14	Not used
7	Movements speed lever	15	Remote control on/off key
8	Boom head solenoid valve lever	16	Remote control and horn enable button

Table 1: Radio control description

### 7.16.1.1 - Remote control display

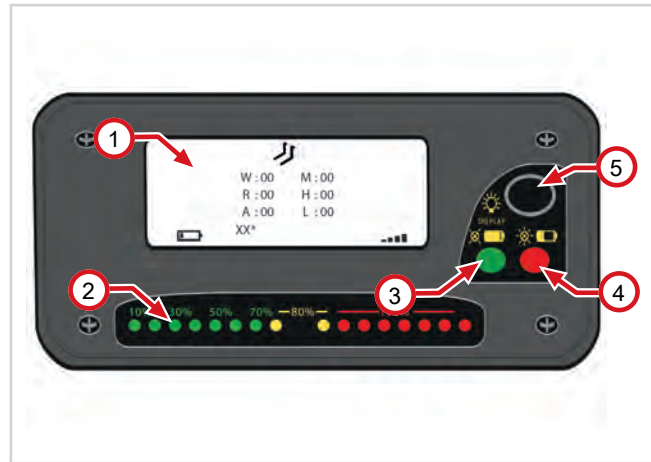

	Description
1	LCD display
2	Anti-tipping led signaling
3	Remote control status LED
4	Remote control battery status LED
5	Not used
W	Current weight
M	Maximum weight
R	Radius
H	Load height from the ground
A	Boom angle
L	Boom extension length
xx*	Installed equipment code
	Forks operating mode icon
	Hook operating mode icon
	Basket operating mode icon
	Battery charge level
	Remote control signal level
	Fuel low level icon
	General alarm icon









Description	
	Active electric contact icon
	Solenoid valve on boom head icon
	F1 function icon (optional depending on the equipment installed)
	F2 function icon (optional depending on the equipment installed)
	F3 function icon (optional depending on the equipment installed)
	F4 function icon (optional depending on the equipment installed)
	Chains error icon (present if the vehicle is prearranged with PLE)
	Levelness icon (present if the vehicle is prearranged with PLE)

Table 2: Display description and legend



### 7.16.1.2 - Remote control emergency stop button

The emergency stop button "9" (fig. 160601-1) turns off the diesel engine of the vehicle and the remote control, stopping all movements of the vehicle and of the equipment.

### 7.16.1.3 - Movements speed lever

The movements speed lever "7" (fig. 160601-1) allows to set the vehicle boom speed.



Move the lever up to set the fast movements (hare symbol)



Move the lever down to set the slow movements (tortoise symbol)

**When using the basket, only slow movements are enabled.**

### 7.16.1.4 - Accelerator lever

The throttle lever "11" (fig. 160601-1) allows to maintain constant diesel engine revolutions of the vehicle.



Move the lever forward to increase the engine rpm of 200 rpm.



Move the lever backward to decrease the engine rpm of 200 rpm.

### 7.16.1.5 - Remote control on/off key

The on/off key "15" (fig. 160601-3) allows to turn on and turn off the remote control. To turn on the remote control, turn the knob from position O to position I.

### 7.16.1.6 - Remote control and horn enable button

The button "16" (fig. 160601-3) is used both to enable the remote control commands and to operate the horn of the vehicle.

### 7.16.1.7 - Boom control levers

The boom control levers are used to carry out various movements:

#### Boom lowering / lifting lever "2" (fig. 160601-1)



Boom down



Boom up

#### Boom extension / retraction lever "3" (fig. 160601-1)



Boom extension



Boom retraction

#### Services lever "4" (fig. 160601-1)



Services



Services

#### Turret rotation lever "5" (fig. 160601-1) [if present]



Turret anti-clockwise rotation



Turret clockwise rotation

#### Tilting lever "6" (fig. 160601-1)



Tilting downwards



Upwards Tilting

### 7.16.1.8 - Electric contact on boom head button

The button "12" (fig. 160601-2) allows to activate the electrical contact on the boom head (if present). Press again the button to disable the electrical contact on the boom head.

### 7.16.1.9 - Boom head solenoid valve lever

The lever "8" (fig. 160601-1) allows to activate the solenoid valve on the boom head (if present).

**7.16.2 - Remote Control: Use**

The vehicle, if prepared, can be used by the remote control.

The movements that can be performed from the remote control are:

- Telescopic boom extension/retraction.
- Telescopic boom Up/Down movement.
- Tilting.
- Turret rotation
- Services.

To use the vehicle by remote control carry out the following operations:

**Operations on the vehicle:**

Assemble the equipment on the vehicle, if not already installed. (Refer to the chapter "Equipment installation" and set the correct mode of use of the vehicle)

- Lay the load on the ground.
- Level the vehicle (if available).
- Place the vehicle on outriggers.
- Place the gear lever to neutral "N" position.
- Engage the parking brake.
- Press the switch "1" (fig. 150912-1) to enable the controls from the remote control. Pressing the switch will automatically shut down the vehicle engine.

Turn the vehicle ignition key in position "I" without starting the engine.

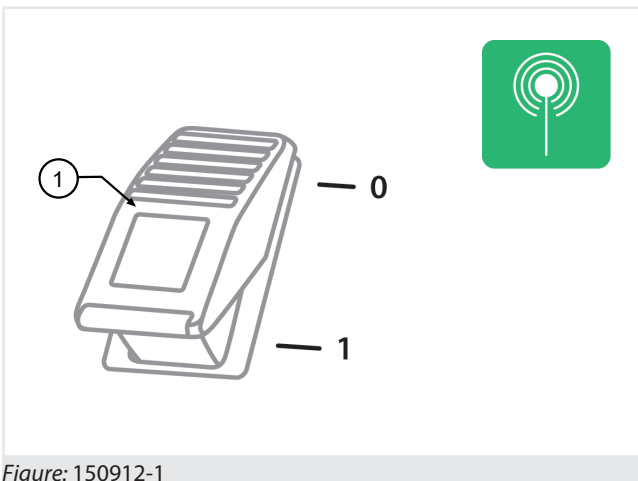

Figure: 150912-1

**Operations on the remote control:**

- Turn the remote control on/off knob "15" (fig. 150912-2) to position "I".
- Press the remote control on/off button "16" to enable the remote control.

- Move the vehicle on/off lever "4" (fig. 150912-3) up and hold it for 2 seconds.

The ON remote control indicator light will flash green until the remote control will remain on.

When switching on the remote control, it will emit an alert tone.

If the gear lever of the vehicle is not in position "N", the vehicle will not turn on.

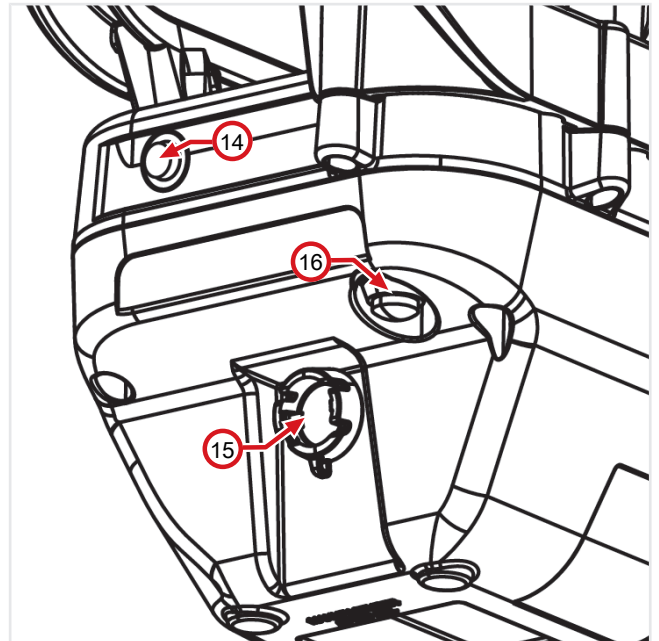

Figure: 150912-2

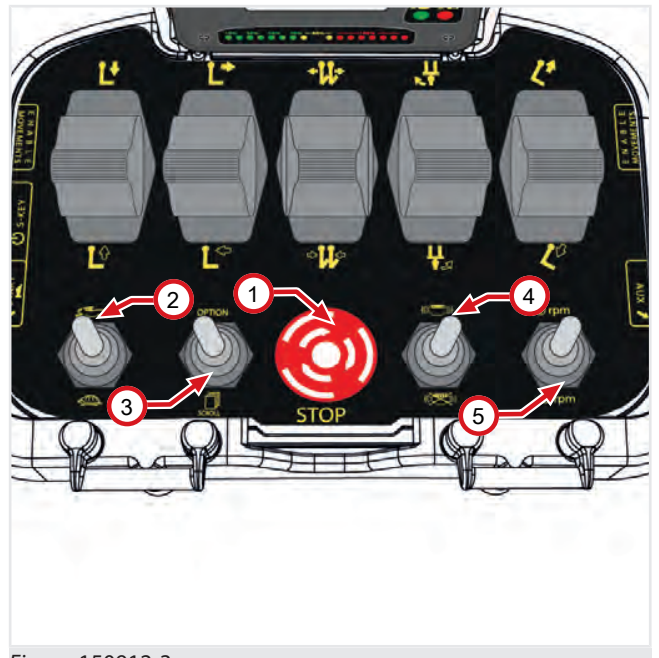

Figure: 150912-3



**WARNING**

Always remain at a safe distance from the vehicle and from the load, outside the area that would be occupied in case of vehicle overturning and load fall.

When using the vehicle with remote control:

- The emergency button in the cab is always active.
- The gear of the vehicle is inhibited.



## NOTE

After 4 min of non-use of the remote control, the remote control and the vehicle will turn off.



## ATTENTION

**When using the vehicle with remote control, a red flashing light on the vehicle comes into operation when the vehicle reaches the tipping limit.**

To reset the vehicle in safe conditions, make movements that do not aggravate the stability depending on the type of equipment currently used.

### 7.16.3 - Remote Control: Turn off the vehicle and the remote control

To turn off the machine engine and the remote control, turn the ignition knob from position "1" to position "0".

### 7.16.4 - Remote Control: Receiver

The remote control receiver is installed on the rear of the vehicle. When the remote control is selected in the cab, the receiver turns on. For the operating specifications carefully read and learn the use and maintenance instructions of the remote control manufacturer.

### 7.16.5 - Remote Control: Recharge

At the seat side there is the remote control battery charger.

### 7.16.6 - Remote Control: Back-up

If the transmitter unit can not be used, it can be replaced by a Transmitting Unit called "BACK-UP UNIT", to be requested to Autec.

It is identical to the Unit that can no longer be used and is distinguished only by the presence of the word "BACK-UP UNIT" in the battery housing.



## ATTENTION

Insert the "Key ID 0-1" or the "ID internal tx memory" of the transmitting unit that is no longer usable in the "BACK-UP UNIT" and perform the procedure for storing the address described below.

### Storing the address

With the battery charged and the ignition key inserted in the "BACK-UP UNIT", carry out the following procedure:

- press the STOP button,
- Press the START button and keep it pressed until the green LED turns off,
- disengage the STOP button.

Now it is possible to start the Remote control and command the vehicle with the "BACK-UP UNIT" transmitting unit.

### 7.16.7 - Remote Control: Additional information



## NOTE

For additional information on the use and maintenance of the remote control, refer to the specific manual of the remote control.

## 7.17 - Electronic hand throttle

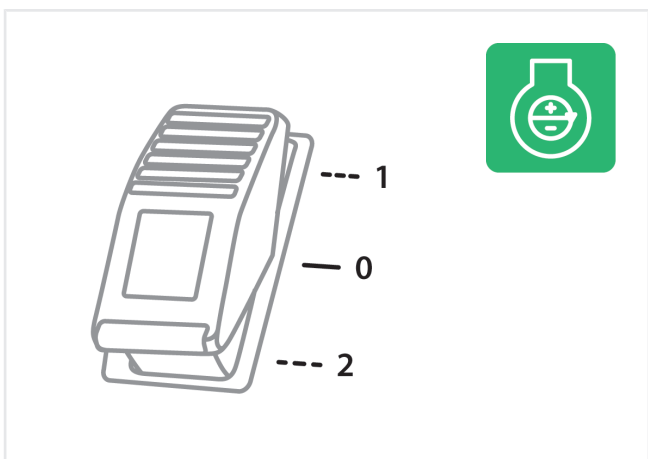

Figure: 150743-1

The hand throttle (fig. 150743-1) allows to maintain constant engine revolutions, without pressing the accelerator pedal.

- Press the Hand throttle on the top "1" to increase the engine revolutions of 200 rpm.

- Press the hand throttle on the bottom "2" to decrease the engine revolutions of 200 rpm.

To deactivate the function, press the accelerator pedal.



**ATTENTION**

With the hand throttle in operation, the vehicle travel is disabled.



**ATTENTION**

When turning off the machine, the function must be disabled and the engine must be brought to the minimum speed.



**WARNING**

Do not use the electronic throttle in the cab during the use of the basket and/or of the remote control.

**7.18 - Automatic differential lock \***



**NOTE**

\* The automatic differential lock is an optional setup.



Figure: 150913-1

The operation of the automatic differential Lock on the 2nd axle (fig. 150913-1) starts automatically in the event of a slip over 45% of one of the two wheels.

**7.19 - Automatic axle swing lock**

The automatic axle swing lock avoids possible oscillations of the vehicle during the working operations when the vehicle is used on wheels.

The indicator lights 1, 2 and 3 (fig. 150914-1) indicate which axles are locked at that time.

The deck swing lock is automatically activated depending on the position of the turret:

- when the turret is located within +/- 10° rotation with respect to the front position ("A" area) only the front axle is locked.
- when the turret is located beyond +/- 10° rotation with respect to the front position ("B" area) both axles are locked: front and rear.
- If the vehicle is equipped with the optional "reversed driving" option, when the turret is located within +/- 2 ° rotation with respect to the 180° rotated position ("C" area) only the rear axle is locked.

**NOTE!** If both axles of the vehicle are locked by the automatic axle swing lock, the gear of the vehicle is inhibited. To travel it is necessary to move the turret in line with the machine.

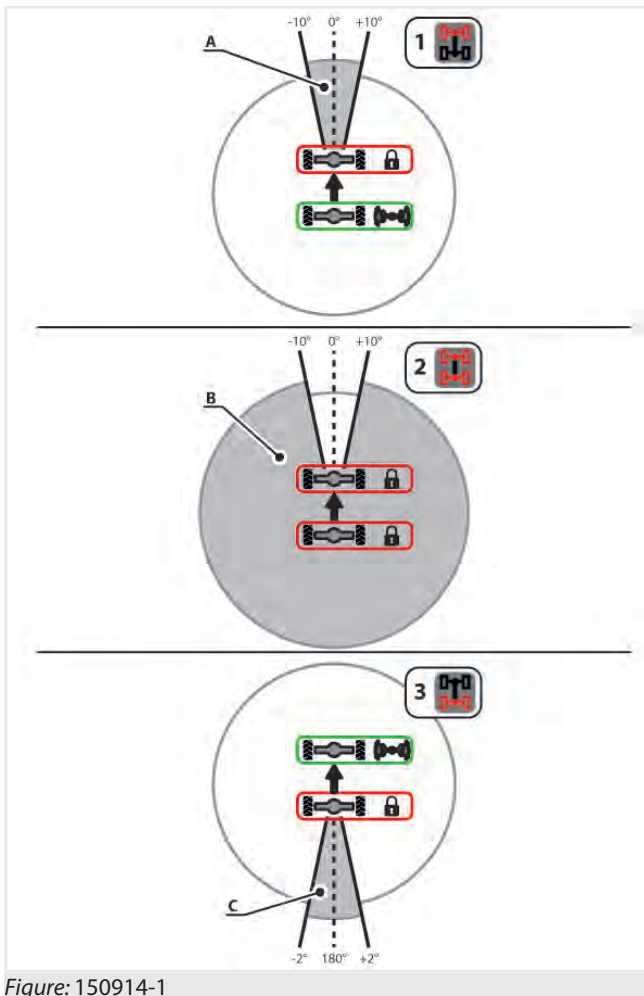

Figure: 150914-1

## 7.20 - Automatic fan reversal

The fan reversal allows precisely the radiator fan reversal to clean the radiator from any dirt deposits such as dust and straw.

The cleaning cycle is automatically activated when the vehicle it turned on and subsequently every hour of continuous work.

The reversal is carried out automatically without having to stop the vehicle.

The fan will remain in the "cleaning" position (reversed motion) for a time preset by the manufacturer.



### ATTENTION

The fan reversal presence does not exempt the user from cleaning the fan, radiator and engine compartment, at the intervals indicated by regular maintenance.

## 7.21 - Transverse levelling device \*



### NOTE

The transverse levelling device is an optional accessory.

The transverse levelling device allows to adapt the vehicle to the transverse inclination of the ground.

To level the vehicle it is necessary to:

- Position the load on the ground.
- Lower and fully retract the telescopic boom.
- Press the transverse levelling device button (fig. 150316-1):
  - From the left side "1" to tilt the vehicle to the left.
  - From the right side "2" to tilt the vehicle to the right.

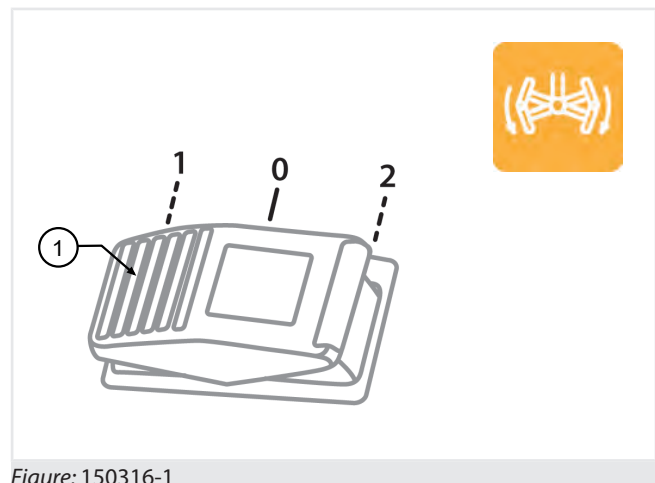

Figure: 150316-1



### DANGER



**It is not possible to work with tilting greater than 2°. Danger of transverse tipping.**

Use the spirit level in the cab to check the inclination of the vehicle.

## 7.22 - Boom down control valve \*



### NOTE

\* The boom down control valve is a standard accessory. It is not present in the case in which the vehicle is prepared for the use of the man basket or the telescopic boom has more than one extension.

The boom down control valve allows the operator to obtain the maximum lowering speed of the boom also at the minimum number of revolutions of the engine; the boom movement speed depends only on the proportional controls of the joystick.

The boom down control valve arm allows faster and more precise movements of the boom and a fuel saving during the boom down movement.

When present, the boom down control valve is always active.

## 7.23 - FPT Series NEF4, Stage IIIA /Tier 3



### NOTE

The use and maintenance manual of the engine is an integral part of the documentation supplied with the machine.

Consult the engine manual or contact an authorized workshop for maintenance.













We recommend that you carefully read the information contained in the instruction manual and comply with them: in this it is possible to avoid accidents, enjoy the manufacturer's warranty and always have an engine in peak operating condition.





## NOTE

The vehicle is supplied with the equipment useful for the vehicle use and maintenance.

	<p><b>Tool bag</b> The tool carrier bag is made up of:</p>
	<p>Socket wrench</p>
	<p>Set of wrenches</p>
	<p>Screwdriver</p>
	<p>Lubricator</p>
	<p>Set of rubber plugs for quick couplings</p>
	<p>Rod for emergency recover pump (Only with man basket prearrangement)</p>
	<p>Adaptor cable for engine diagnostics (Only FPT engines Stage IIIB/Tier 4i version and following)</p>
	<p>Protruding load signal (only Italy)</p>
	<p>Rotating light</p>
	<p>Pin for vehicle tow hitch</p>
	<p>Pin for trailer hitch (only tractors)</p>





## 9.1 - General warnings on equipment use



### DANGER

It is strictly forbidden to modify the structure of the equipment or adjust the safety devices of the various tool components.

- Only Equipment CE certified by the relative manufacturer can be used on **DIECI** vehicles, as well as equipment approved or falling within the technical limits set out by **DIECI S.r.l.** The guarantee is void if not approved equipment is used.
- The Tool does not require CE certification.
- **DIECI S.r.l.** liability shall not be involved if equipment use or modifications do not comply with the above mentioned requirements.



### ATTENTION

**The equipment installed on the vehicle may only be used:**

- a) on consistent ground and with vehicle level with maximum tilt of 2°.
  - b) by competent and qualified personnel who must have read this manual. In the case of road use refer to the Use and Maintenance Manual of the vehicle making sure that the operator is in possession of a valid driver's license in accordance with the laws in force in the country of use (license B or higher for ITALY), and that the vehicle boom is in the fully retracted position.
- Some equipment be accompanied by instructions related to safety standards, connection and disconnection, operation and maintenance. Carefully read and fully implement these instructions prior to installation, use and maintenance of the equipment. In case of doubt, contact your local dealer.
  - Before starting to use the vehicle and related equipment, or before performing particularly complex or dangerous operations, it is absolutely necessary to practice in a clear work area free from obstructions.
  - In case of poor visibility of the zone use a person on the ground to coordinate the movements and operations and that monitors the area inviting people who might come, to go away. The

individual on the ground must stand at a safe distance from the vehicle in motion and alert, before any movement, any personal around.

- To prevent damaging hydraulic fittings when changing an equipment, stop the engine and wait a few seconds to remove pressure from the circuit. Always clean the fittings before their reinsertion.
- Check the cleanliness, protection and conditions of quick release joints in the equipment circuits and on the boom head daily.



### DANGER

Never carry the equipment in the vicinity of an open flame.



### DANGER

**When using the vehicle, carefully follow the respective Load charts.**

It is strictly prohibited to work without the respective load charts for the type of vehicle and installed equipment.

- The indications given by the anti-tipping system of the vehicle must be considered valid for standard working conditions, on flat and solid ground with well-operating and properly calibrated equipment. In any case, the values indicated by the load charts must be respected and never exceeded.
- It is mandatory, every time the equipment is used to insert the safety plugs to secure the equipment to the Attachment holding plate.
- If an attachment holding plate different from the original Dieci attachment holding plate is installed on the vehicle, a residual load will remain on the anti-tipping device of the vehicle as a safety factor.
- Refer to the manual of the manufacturer of the attachment holding plate installed if different than the original Dieci attachment holding plate.



### ATTENTION

**When moving the vehicle with equipment or man baskets installed, maintain a speed appropriate to the type of ground.**

When driving on rough terrain it is advisable not to exceed 10 km/h (6,2 mph) to prevent vibration and pitching phenomena, damaging the equipment or the man basket installed on the vehicle.



## WARNING

**It is possible that in certain working conditions there is no interference between the attachment holding plate and/or the equipment and the vehicle chassis or wheels.**

Pay due attention to prevent damage to the vehicle. Lift and extend the boom just enough to avoid interference.

### 9.1.1 - Equipment pre-use checks



## NOTE

Refer to the pre-use safety procedures of the vehicle on which the equipment is installed.

Before every use and every time new equipment is installed on the vehicle:

- Check that the equipment is properly hooked to all the pins and the hooks are inserted in the correct position.
- There is no damage, deterioration, deformation of the equipment locking components.
- Check that the equipment and components are intact, perfectly functioning and not damaged.
- Verify that the equipment capacity is more than the weight of the load to be moved.
- Verify the correct functioning of the equipment and of the controls present in the vehicle cab on which the equipment is installed in a work zone free from personnel and obstacles.
- Verify the functioning of all indicators and lights present inside the vehicle on which the equipment has been mounted.
- Check the swiveling when empty.
- Check the oil level in the hydraulic circuit.
- Check that the safety symbols and stickers are clearly legible.
- Check the efficiency and functioning of the safety devices.
- Visually check the state of welding, inspect the vehicle and check for cavities, cracks of the welding or base metal or other inconveniences.
- Check for any deformations and/or modifications of the material due to sudden temperature changes or damage from impacts.
- Check the equipment for wear.
- Verify the use mode relating to the installed equipment has been set on the vehicle.

- Verify that the Capacity diagrams relating to the vehicle and installed equipment are present on the vehicle.

In case of equipment with hydraulic connections:

- Check that the tubes are in good conditions and do not obstruct the movements of the boom or of the equipment.
- Verify the correct connection of the hydraulic tubes (if present) ensuring that the equipment functions are not inverted.

In case of equipment with electrical connections:

- Check that the cables are in good conditions and do not obstruct the movements of the boom or of the equipment.
- Clean and fasten all the electrical connections (if present). Check before each work shift that there are no loose, twisted, hardened or damaged wires. Do not operate the operating vehicle if there are any loose, twisted, hardened or damaged electric cables.

In the event of radiocontrol pre-arrangement:

- Refer to the specific manual of the equipment for further checks.
- Verify the correct functioning of the radiocontrol/push button control panel and the charge status of the batteries.

In case lifting equipment is used

- Refer to the specific manual of the equipment for further checks.
- Verify the integrity of the lifting hook, including relative catch, and of the hook bolt to the rope.

In case winches are used

- Refer to the specific manual of the equipment for further checks.
- Check that the rope is not damaged, cut, torn, frayed. On the contrary, do not use the equipment and replace it. (This check can be carried out by fully extending the lift boom and unrolling the winch rope). During this operation it is also possible to check the operation of the limit switch, which must lock the rope according to the procedure described in the specific paragraph.
- Verify the functioning of the extensometric transducer of the mounted equipment (if present); to do this, try to lift a load slightly

heavier than the nominal maximum capacity of the equipment. In case the equipment is unable to lift the load, the transducer operates correctly, otherwise immediately interrupt the operation bringing the load to the ground and repair the equipment.

### In case of using elevating work platforms

- Refer to the specific manual of the equipment for further checks.
- Verify the operation of the emergency button of the load limiting device and of the area limiting device at the beginning of each work cycle.
- Before using the platform ensure it is not wet, dirty with grease, oil, has icy surfaces or covered with other substances that can make its surface slippery. On the contrary, accurately clean and dry the platform surfaces. Danger of slipping and falling.
- The vehicle on which the equipment is installed must be braked and stabilized on solid ground. If outriggers (optional) are present, position them correctly on the ground before starting to operate.
- Before operating, make sure that the openings for access to the platform are in the closed position; always verify the correct engagement of the safety harnesses (PPE category III).



## ATTENTION

**All checks must be carried out by adequately trained personnel and registered on the control log.**

If damage or malfunctioning is detected, comply with the instructions contained in this manual or in the manual of the equipment or basket or contact the DIECI Assistance Center to agree the actions to be taken.

If routine or extraordinary maintenance or technical adjustment of the equipment is required, contact exclusively personnel authorized by the DIECI Assistance Center and note the service intervention on the control log.

If the equipment is tampered with, the guarantee is voided and the Manufacturer is relieved of all liability.



## DANGER

Operators who note anomalies on the equipment or on the vehicle on which it is installed, and it does not conform to safety regulations must suspend use and immediately inform the Person in charge.



## NOTE

For road circulation, refer to the Use and Maintenance Manual of the vehicle on which the equipment is installed.

### 9.1.2 - Bucket warnings



## WARNING

**Pay particular attention to the following points when using the vehicle with bucket.**

- We recommend a limited and occasional use of the vehicle with bucket.
- Intensive use can damage the boom, so maintenance intervals should be halved.
- It is forbidden to push the bucket against the material with the extension movement.
- When pushing with the bucket against the material it is necessary to:
  - Keep the wheels straight;
  - Keep the boom closed;
  - Lower between the two chassis guides (if present);
  - Do not push the boom down lifting the two front wheels;
  - Do not excavate with the bucket
- It is forbidden to use buckets larger than those specified in the price list.
- It is forbidden to use buckets that are not "DIECI", in case you want to use buckets that are not "DIECI" contact the customer service.
- It is permitted to use the vehicle with the bucket only for carrying work.



## ATTENTION

**It is important that there is always visibility by the operator on the bucket work area. A bucket that is too large limits the operator's visibility and can damage the vehicle.**

## 9.2 - Equipment installation procedure

To properly install equipment carry out the following operations (fig. 150507-1):

1. Remove the safety pin "2" (if installed) by removing the safety plug "1".
2. Place the equipment on a flat not yielding surface, to be able to smoothly engage it with the attachment holding plate of the vehicle.
3. Place the vehicle with the boom lowered parallel to the tool. Approach the attachment holding plate to the accessory extending the telescopic boom. The vehicle can not extend the boom if it is completely lowered. Slightly raise the boom to be able to extend it.
4. Using the tilting movement, rotate the attachment holding plate downward. Bring the top of the plate under the locking hooks of the tool.
5. Slightly lift the boom and rotate the attachment holding plate upwards, thus making the equipment adhere to the attachment holding plate of the vehicle. During this operation, make sure that no person is in the vicinity of the equipment or the vehicle boom.
6. Turn off the engine and get out of the vehicle.
7. Insert the safety pins "2" in their seats on the attachment holding plate, passing through the corresponding slots of the equipment. In the case the two holes do not match, perform the steps described in chapter "Safety pin outline"
8. Fit the safety plug "1" on the pins just inserted.
9. In the event that the equipment needs electrical or hydraulic connections, refer to the "Hydraulic pipes connection" and "Electrical cables connection" chapters.
10. Once properly fixed the equipment, turn on the vehicle and set the correct mode of operation of the vehicle related to the newly installed equipment:
11. Consult the use and maintenance manual of the vehicle to set the correct mode of use.
12. Check that in the cab there is the load chart related to the vehicle and to the equipment just installed.

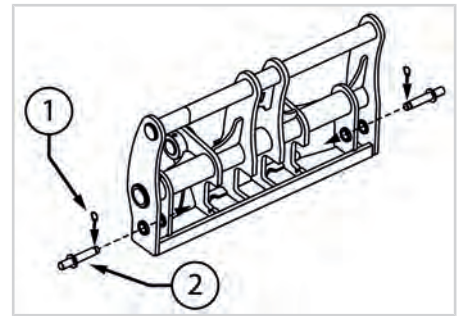

150507-1

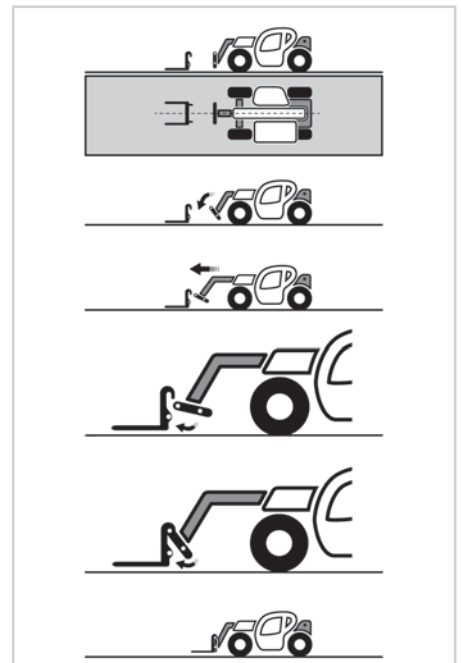

150507-2



### DANGER

In case, for deformation, the pin and the related safety pin do not reach the required position, it is absolutely forbidden to use the accessory as it may come off and fall to the ground dangerously.



### DANGER

It is forbidden to operate without the safety pin installed on the attachment holding plate.

**WARNING**

When using an equipment that has electrical or hydraulic connections these must always be correctly connected to the vehicle. Failure to connect does not allow the proper operation of the safety devices with risk of damage to property and persons and risk of vehicle tipping.

**DANGER**

It is forbidden to operate with a mode of use of the vehicle not suitable for the type of equipment installed. The electro-hydraulic equipment will not work correctly and safety devices will not be in operation creating a risk of damage to property and people and the vehicle risk of tipping.

**DANGER**

**It is forbidden to operate without the proper load chart related to the vehicle and to the equipment installed.**

For more details on the accessory installation procedures or warnings, consult the use and maintenance manual of the accessory.

**ATTENTION**

**Before each use, check that:**

- a) The equipment is properly hooked to all the pins and hooks are inserted in the correct position.
- b) There is no damage, deterioration, deformation of the equipment locking components
- c) If present, the electric cables or hydraulic pipes are in good condition and do not create hindrance while using the equipment
- d) The mode of operation of the vehicle is consistent with the type of equipment installed
- e) In the cab there are the load charts related to the vehicle and to the equipment installed.



## 9.3 - Hydraulic connections

### 9.3.1 - Warnings for hydraulic connections



#### NOTE

Before making the hydraulic connections, perform the "Equipment installation procedure" and check the equipment is correctly fixed to the vehicle.

Check the hydraulic tubes do not obstruct the movements of the vehicle or of the equipment as it may be damaged.

Consult the equipment manual to verify correct operation.



#### WARNING

When using an equipment that has electrical or hydraulic connections these must always be correctly connected to the machine. Failure to connect does not allow the proper operation of the safety devices with risk of damage to property and persons and risk of machine tipping.



#### NOTE

Always accurately clean the hydraulic connections before each coupling. If not used, both the hydraulic connections must be protected with adequate plastic caps.



#### WARNING

Do not use the vehicle or the equipment if the hydraulic tubes are worn or damaged, but repair or replace them.



#### WARNING

**Once the hydraulic connections have been made, it is compulsory to verify that the controls are consistent with the operations carried out on the vehicle.**

By inverting the connections, the accessory functions may be inverted compared to normal use, therefore, after having completed the equipment installation procedure, test the various functions in a free zone.



#### DANGER

##### Hydraulic liquid under pressure

Fine jets of hydraulic oil at high pressure can penetrate the epidermis. Keep hands and face at a safe distance from the pressurized fluid and wear goggles and protective gloves. Bring a piece of cardboard to the area of the suspected leak and then check for traces of liquid on the cardboard. If the liquid penetrates the skin immediately seek for medical advice.



#### DANGER

##### Hydraulic pressure

The leakage of hydraulic oil at operating pressure can cause injury: before connecting or disconnecting the hydraulic hoses, release the residual pressure from the hydraulic circuit. Prevent starting the engine with disconnected hoses.

### 9.3.2 - Type of hydraulic quick couplings

The hydraulic quick couplings at boom head can be of two types:

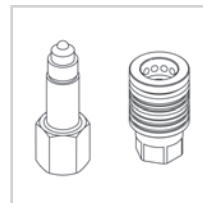

Push-Pull (fig. 150509-1)

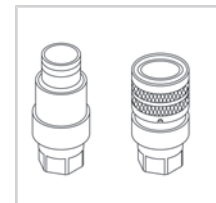

Flat-Face (fig. 150509-2)

### 9.3.3 - References for correct connection

To make the correct connection of the hydraulic fittings, each hydraulic plug or socket is marked with a colour or symbol.

- The **red** plugs must be connected to the **red** sockets or those with the "+" mark.
- The **blue** plugs must be connected to the **blue** sockets or those with the "-" mark.

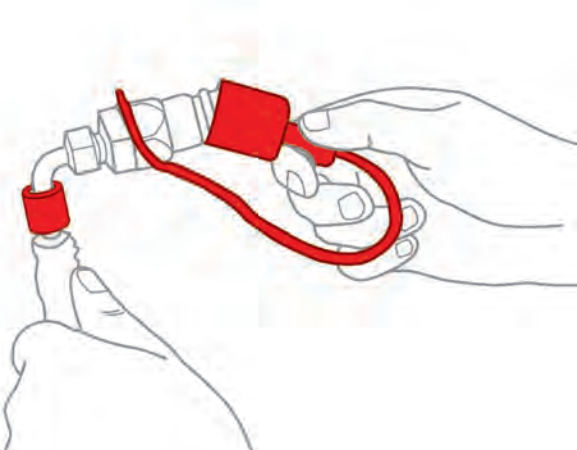

Figure: Cap and mark on the hydraulic sockets



Figure: Hydraulic sockets on boom head

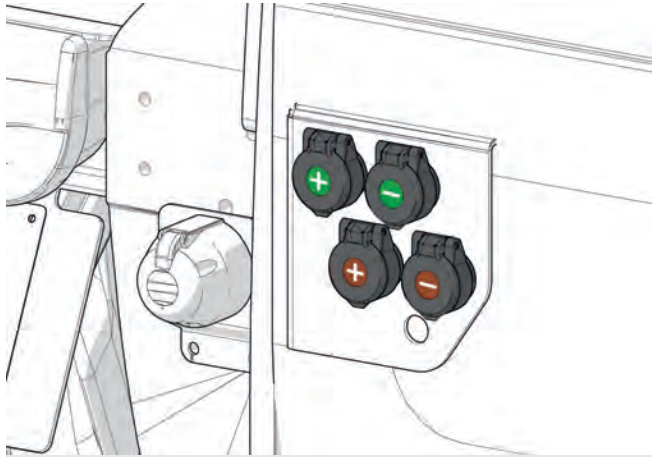

Figure: Rear hydraulic sockets



**WARNING**

**Equipment with hydraulic connections made incorrectly have movements or functions that do not agree with the operator's controls and can cause damage to other operators, material handled or to the vehicle and equipment.**

Always make sure that the hydraulic connections follow the indications given above for proper connection and that the movements and functions of the equipment comply with the operator controls.

**9.3.4 - Push-Pull couplings connection**

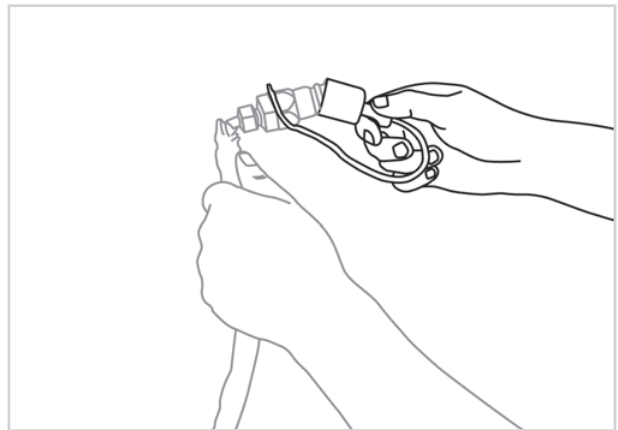

150510-1

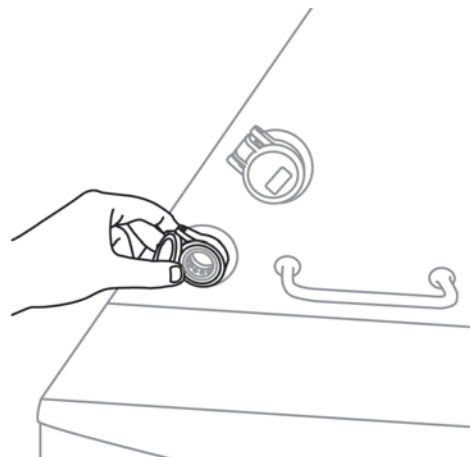

Figure: 150510-2

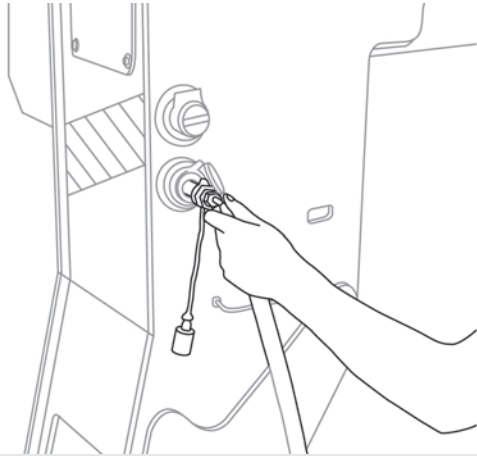

Figure: 150510-3

To connect the Push-Pull quick couplings to the sockets on the boom head:

1. Perform the equipment installation procedures described in the chapter: "Equipment installation procedure".
2. Turn off the vehicle.
3. In case of closed centre distributor, relieve the system residual pressure (refer to chapter Closed centre distributor: Relieve the pressure by pressing the pressure relief button \* [▶ 135]).
4. Remove the protection cap from the equipment hydraulic plugs (fig. 150510-1).
5. Lift the protective cover for the hydraulic socket present on the boom head (fig. 150510-2).
6. Clean the plug and socket, if soiled.
7. Fit the plug inside the socket and press until the pipe is blocked (fig. 150510-3).
8. Check that the hydraulic pipe is correctly fixed.
9. Carry out the same operation for both pipes.



**NOTE**

Consult the equipment manual to verify correct operation.

9.3.4.1 - Push-Pull couplings connection when connected to a valve

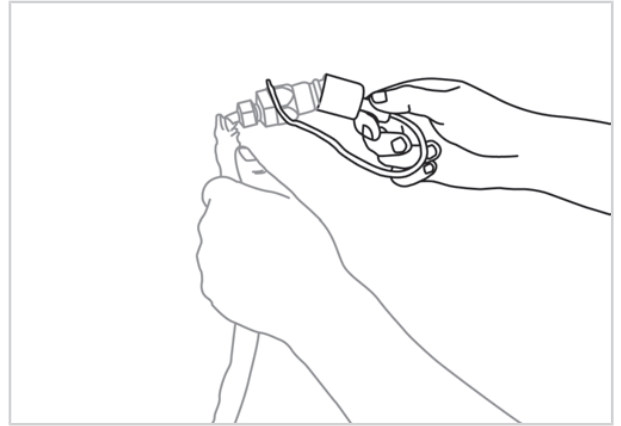

150511-1

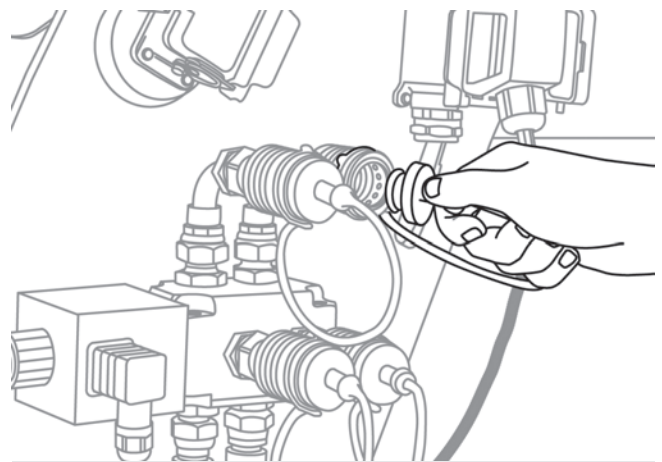

Figure: 150511-2



Figure: 150511-3

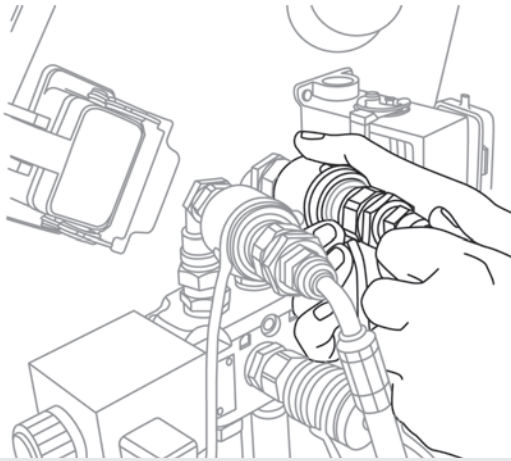

Figure: 150511-4

To connect the Push-Pull quick couplings to the valve on the boom head:

1. Perform the equipment installation procedures described in the chapter: "Equipment installation procedure".
2. Turn off the vehicle.
3. In case of closed centre distributor, relieve the system residual pressure (refer to chapter Closed centre distributor: Relieve the pressure by pressing the pressure relief button \* [▶ 135]).
4. Remove the protection cap from the equipment hydraulic plugs (fig. 150511-1).
5. Remove the protection cap from the hydraulic sockets installed in the valve on the boom head (fig. 150511-2).
6. Clean the plug and socket, if soiled.
7. Push the ring on the valve socket towards the boom (fig. 150511-3).
8. Place the plug fully inside the socket and release the ring of the valve (fig.150511-4).
9. Check that the hydraulic pipe is correctly fixed.
10. Carry out the same operation for both pipes.



## NOTE

Consult the equipment manual to verify correct operation.

## 9.3.5 - Flat-Face couplings connection

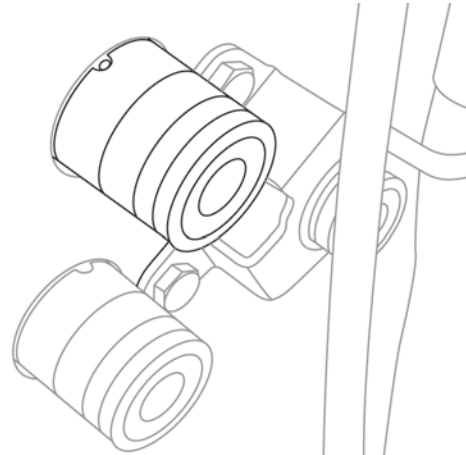

Figure: 150512-1

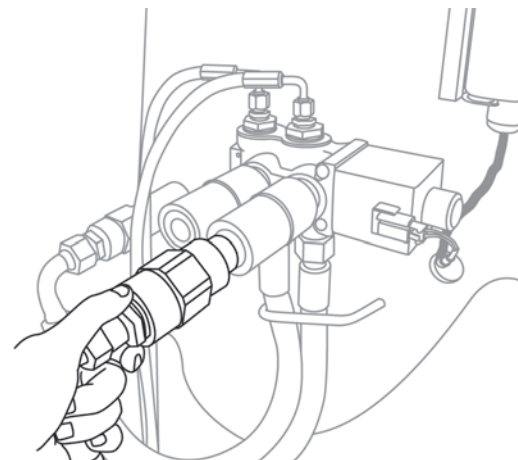

Figure: 150512-2

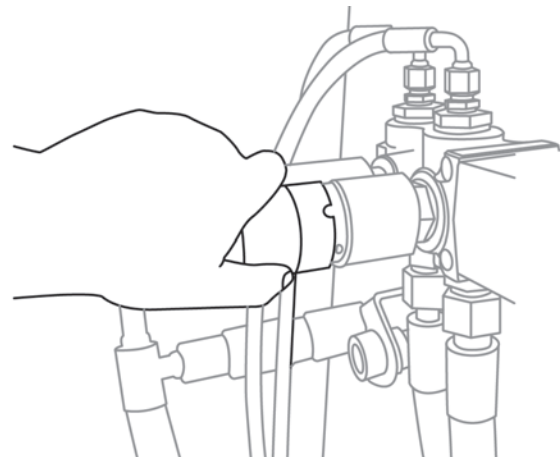

Figure: 150512-3

To connect the Flat-Face quick couplings:

1. Perform the equipment installation procedures described in the chapter: "Equipment installation procedure".
2. Turn off the vehicle.
3. In case of closed centre distributor, relieve the system residual pressure (refer to chapter Closed centre distributor: Relieve the pressure by pressing the pressure relief button \* [▶ 135]).

4. Clean the plug and socket, if soiled.
5. Place the plug at the centre of the socket and fully push the plug (fig. 150512-2), until the socket ring is lifted.
6. Turn the ring to block the plug inside the socket (fig. 150512-3).
7. Check that the hydraulic pipe is correctly fixed.
8. Carry out the same operation for both pipes.



**NOTE**

Consult the equipment manual to verify correct operation.

**9.3.6 - Closed centre distributor:  
Relieve the pressure by pressing the pressure relief button \***



**NOTE**

This operation is possible and it may be required only for vehicles fitted with "Closed centre distributor" and "Trailer descent".

Consequences

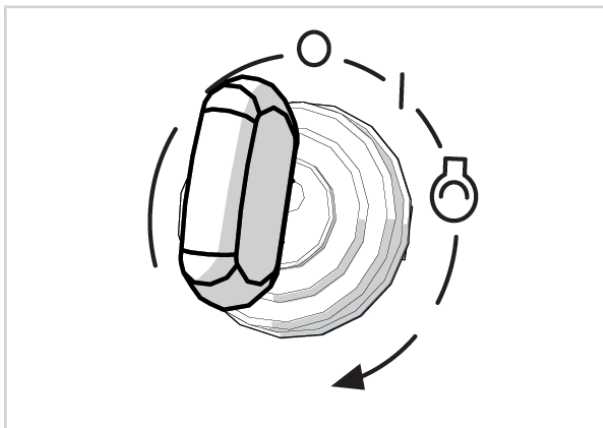

150501-1

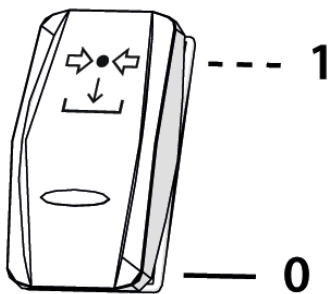

Figure: Pressure relief switch

To relieve pressure it is necessary to:

1. Move the ignition key of the vehicle to position "I" (fig. 150501-2).

2. Select the hydraulic socket still under pressure (if there is more than one hydraulic socket refer to the vehicle manual, chapter "Hydraulic sockets selection").
3. Press the "Pressure relief" switch to release the residual pressure of the selected hydraulic socket.
4. Proceed with the hydraulic couplers connection operation.

**9.4 - Electrical Connections**

**9.4.1 - Warnings for electrical connections**



**DANGER**

**Before making the electrical connections, switch off the vehicle.**

Do not use the vehicle or the equipment if the electrical cables are worn or damaged, but repair or replace them.



**WARNING**

Do not leave the boom plug hanging from the chain during work operations as this may be damaged impairing the vehicle correct operation when used without equipment.



**ATTENTION**

Before making the electrical connection, perform the "Equipment installation procedure" and check the equipment is correctly fixed to the vehicle.



**WARNING**

**When using an equipment that has electrical or hydraulic connections these must always be correctly connected to the vehicle. Failure to connect does not allow the proper operation of the safety devices with risk of damage to property and persons and risk of vehicle tipping.**

Consult the equipment manual to verify correct operation.





## ATTENTION

Check that the electrical cable is not in a position that hampers the movements of the operating vehicle and of the equipment as it could be damaged.

### 9.4.2 - Procedure for connecting electrical connections

The electrical connections on the boom head may be at 6 or 24-pole, but the connection procedure is the same for both.

For equipment provided with electrical system carry out the following operations:

1. Perform the equipment installation procedures previously described.
2. Turn off the vehicle.
3. Disconnect the cover from the socket on the boom "1" (fig. 150512-1) lowering the 2 safety levers "2".

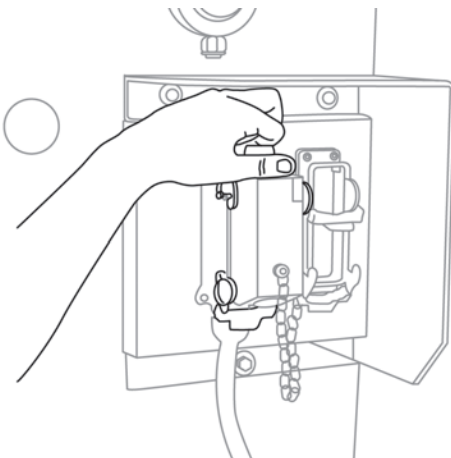

Figure: fig.150512-1

4. Remove the cover located on the boom socket and fit it in the dummy socket aside (fig. 150512-2) and fasten it with the appropriate levers.

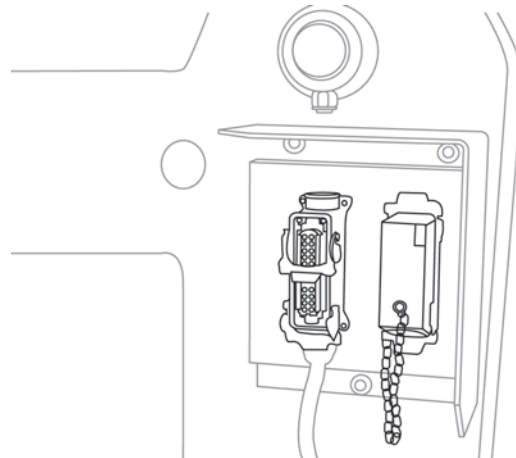

Figure: fig. 150512-2

5. Disconnect the plug from the dummy socket on the equipment "1" (fig. 150512-3) lowering the 2 safety levers "2" (fig. 150512-3).

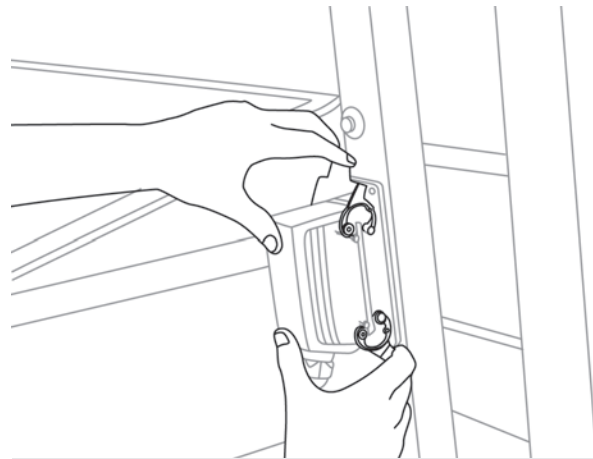

Figure: fig. 150512-3

6. Connect the plug of the equipment on the electrical socket of the boom, fastening it by lifting the 2 safety levers "1" (fig. 150512-4).

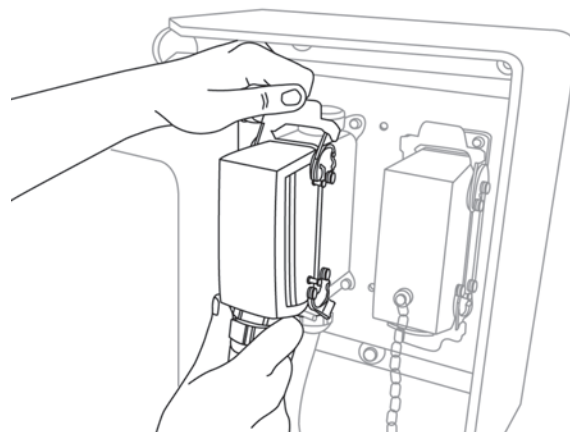

Figure: fig. 150512-4

7. Once the equipment is properly fixed, turn on the vehicle and set the correct mode of operation of the vehicle related to the newly installed equipment.



8. Check that in the cab there is the load chart related to the vehicle and to the equipment just installed.

## 9.5 - Equipment removal

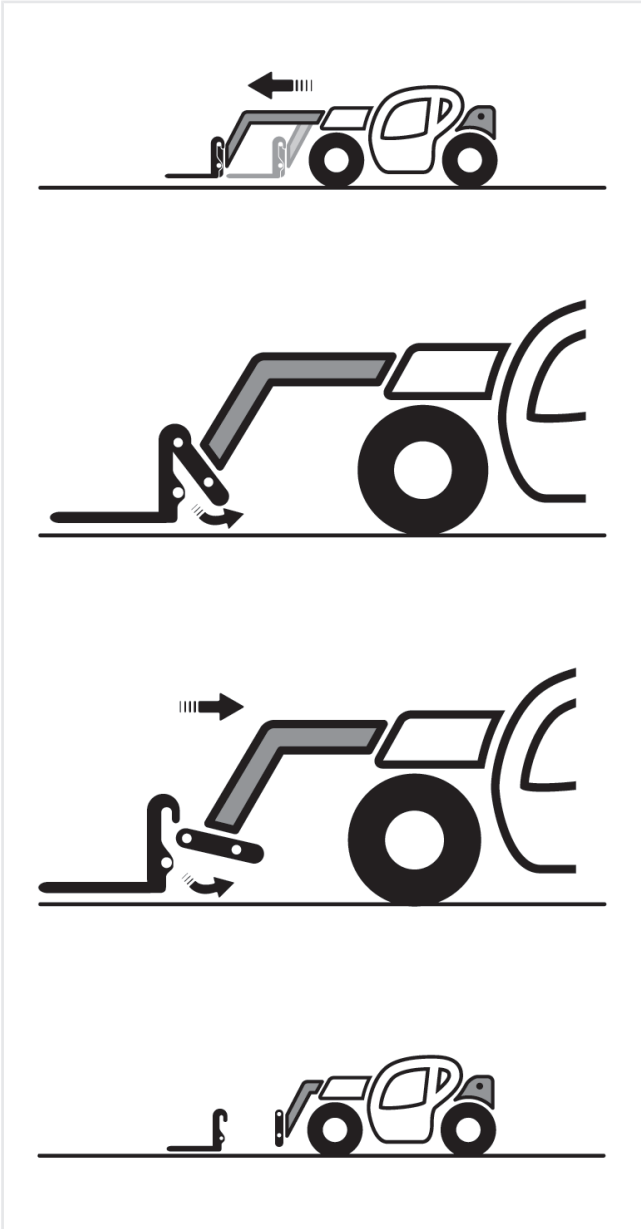

Figure: 150604-1

To store the accessory, once you finished using it, carry out the following operations:

1. Place the vehicle on a solid and level ground.
2. Position the equipment above a support platform to facilitate the handling and transportation of the single piece of equipment.
3. Lower and extend the vehicle boom of about one metre.
4. Turn off the engine.
5. Remove the electrical connections, if any (see the following chapter).

6. Remove the water connections, if any (see the following chapter).
7. Release the equipment following the reverse procedure of the equipment installation in accordance with the type of plate installed on the vehicle.
8. Turn on the vehicle and swing down in order to release the attachment holding plate from the equipment.
9. Once released the attachment holding plate, retract the vehicle boom.



### NOTE

The accessory placed on the ground must always be appropriately marked and barriers and clearances must be laid on all sides of the area that it could occupy falling.



### DANGER

**After releasing the system pressure always wait for a minute before disconnecting the joints.**

Always disconnect the hydraulic pipes and electrical cables of the equipment before releasing it from the vehicle. Otherwise it is possible to damage the pipes or cables and the tool may fall and be dragged.

### 9.5.1 - Electrical connections removal

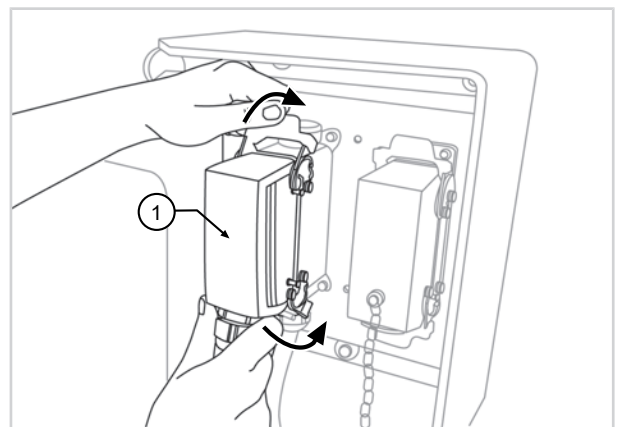

150514-1

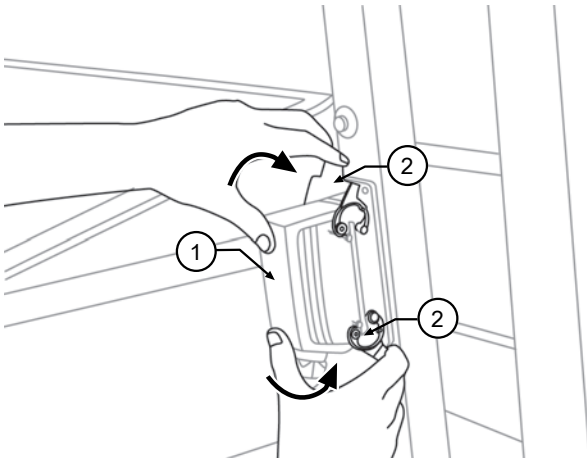

Figure: 150514-2

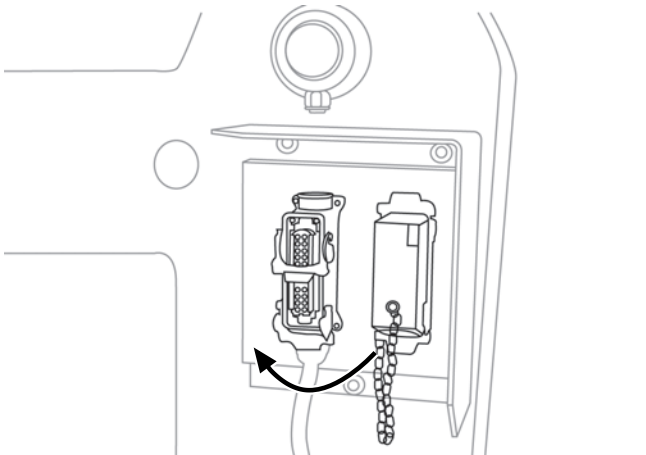

Figure: 150514-3

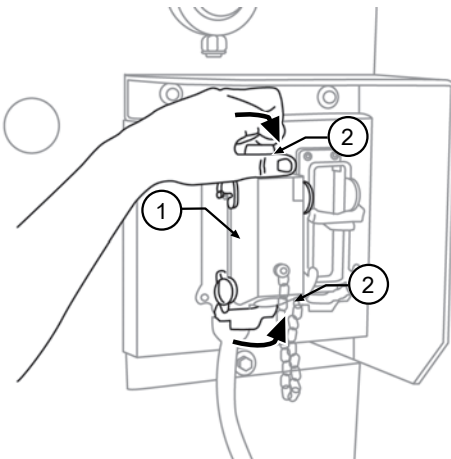

Figure: 150514-4

To remove the electrical connections from the equipment it is necessary to:

1. Follow steps 1, 2, 3 and 4 of the procedure to remove the equipment from the vehicle described in the previous chapter.
2. Disconnect the plug of the equipment from the boom lowering the two safety levers (fig. 150514-1).
3. Position the plug of the equipment on its dummy socket "1" (fig. 150514-2), fastening it with the safety levers "2".

4. Disconnect the cover located on the boom dummy socket and fit it in the electrical socket (fig. 150514-3).
5. Secure the cover to the socket on the boom "1" (fig. 150514-4) through the safety levers (fig. 150514-4).
6. Check that the electrical cables are not trapped in the attachment holding plate or that they can be crushed by the equipment when it will be placed on the floor.
7. Proceed with the subsequent operations to remove the equipment from the vehicle.

### 9.5.2 - Push-Pull couplings removal

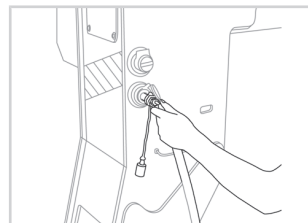

150513-1

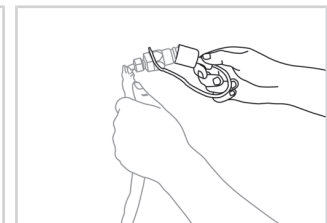

150513-2

To disconnect the Push-Pull quick couplings from the socket on the boom head it is necessary to:

1. Follow steps 1, 2, 3 and 4 of the procedure to remove the equipment from the vehicle described in the previous chapter.
2. If a closed centre distributor is installed on the vehicle, carry out the procedures described in chapter "Closed centre distributor: Relieve the pressure by pressing the pressure relief button \* [▶ 135]" to relieve pressure present in the hydraulic circuit.
3. Turn off the vehicle.
4. Pull the plug towards yourself to remove it from the socket (fig. 150513-1).
5. Clean the plug and socket, if soiled.
6. Fit the protection cap to the equipment hydraulic plugs (fig. 150513-2).
7. Carry out the same operation for both pipes.
8. Check that the hydraulic pipes are not trapped in the attachment holding plate or that they can be crushed by the equipment when it will be placed on the floor.
9. Proceed with the subsequent operations to remove the equipment from the vehicle.

**9.5.2.1 - Push-Pull couplings removal when connected to a valve**

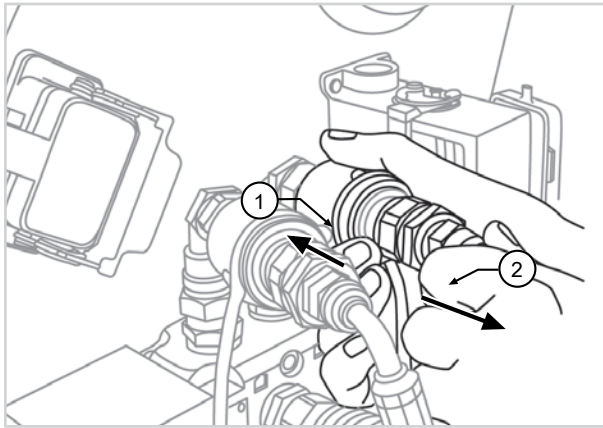

150515-1

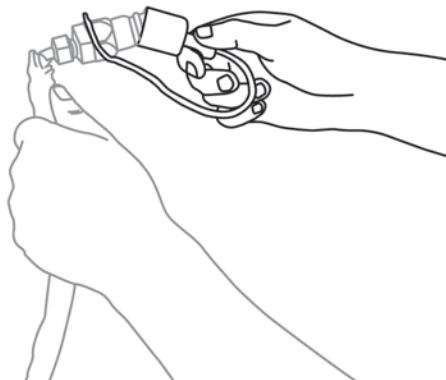

Figure: 150515-2

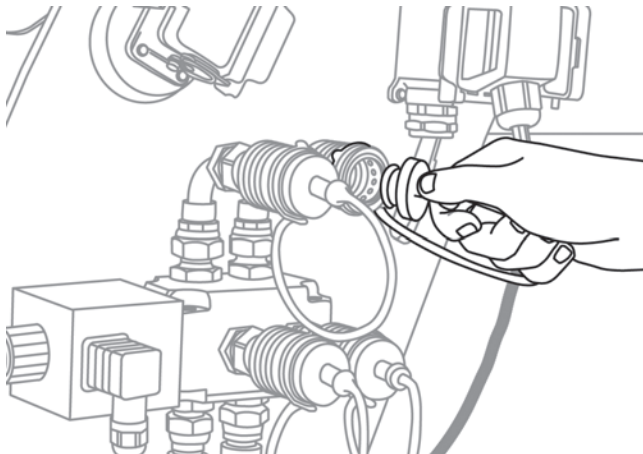

Figure: 150515-3

To disconnect the Push-Pull quick couplings from the valve on the boom head:

1. Follow steps 1, 2, 3 and 4 of the procedure to remove the equipment from the vehicle described in the previous chapter.
2. If a closed centre distributor is installed on the vehicle, carry out the procedures described in chapter "Closed centre distributor: Relieve the

pressure by pressing the pressure relief button \* [▶ 135]" to relieve pressure present in the hydraulic circuit.

3. Turn off the vehicle.
4. Push the ring of the socket towards the vehicle boom "1" (fig. 150515-1).
5. Pull the plug towards yourself to remove it from the socket "2".
6. Clean the plug and socket, if soiled.
7. Fit the protection cap to the equipment hydraulic plugs (fig. 150515-2).
8. Fit the protection cap to the hydraulic sockets of the valve (fig. 150515-3).
9. Carry out the same operation for both pipes.
10. Check that the hydraulic pipes are not trapped in the attachment holding plate or that they can be crushed by the equipment when it will be placed on the floor.
11. Proceed with the subsequent operations to remove the equipment from the vehicle.

**9.5.3 - Flat-Face couplings removal**

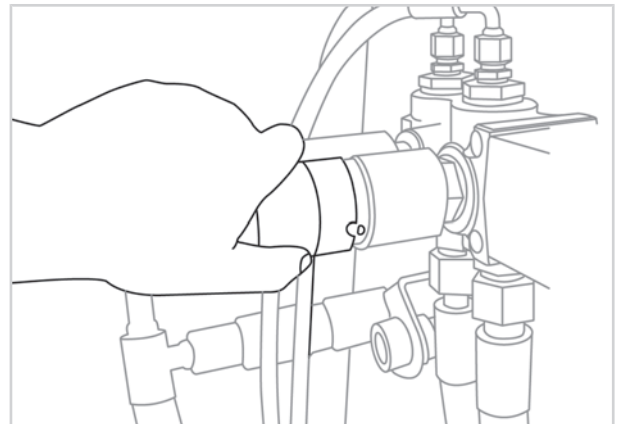

150516-1

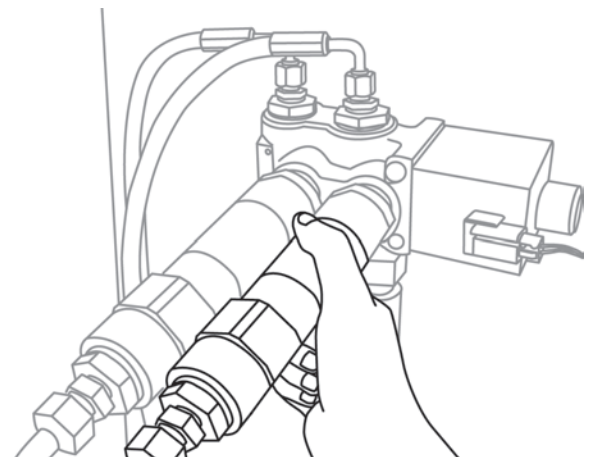

Figure: 150516-2

To disconnect the Flat-Face quick couplings:

1. Follow steps 1, 2, 3 and 4 of the procedure to remove the equipment from the vehicle described in the previous chapter.
2. If a closed centre distributor is installed on the vehicle, carry out the procedures described in chapter "Closed centre distributor: Relieve the pressure by pressing the pressure relief button \* [▶ 135]" to relieve pressure present in the hydraulic circuit.
3. Turn off the vehicle.
4. Turn the socket ring to match the recess with the position of the ball placed on the socket (fig. 150516-1).
5. Push the socket ring "1" (fig. 150516-2).
6. Pull off the plug "2" (fig. 150516-2).
7. Clean the plug and socket, if soiled.
8. Carry out the same operation for both pipes.
9. Check that the hydraulic pipes are not trapped in the attachment holding plate or that they can be crushed by the equipment when it will be placed on the floor.
10. Proceed with the subsequent operations to remove the equipment from the vehicle.

## 9.6 - Forks

### 9.6.1 - Identification

The term "Forks" means the pair of forks to be installed on the vehicle.

The purpose of this equipment is the lifting and handling of a load from the ground upwards, and vice versa.



#### NOTE

The forks may be provided with a spreader/shifter that allows to position the distance between the forks more quickly and safely.

The data necessary for the identification of the forks are positioned on the right side of the forks, in the upper part "A" (fig. 150518-1).

Below are the identification data (their order may be different on the forks).

To ensure a prompt and efficient service when ordering parts or when requesting information or technical clarification always specify the identification details.

Therefore we recommend to note the data relating to the accessory in your possession in order to safely and quickly identify them in the future, in case of need.

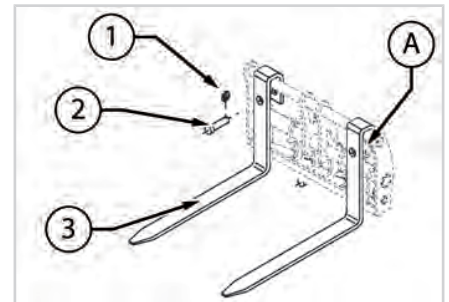

150518-1

<b>Dieci</b> forks code	.....
Manufacturer's Logo/ Abbreviation	.....
Manufacture Date/Batch	.....
Maximum capacity (Kg)	.....
Load application center of gravity (mm) *	.....

\* There may be more than one value depending on the load.

### 9.6.2 - Description

The forks (fig. 150519-1) consist of the following main components:

1. Lock pin
2. Fastening pin
3. Forks

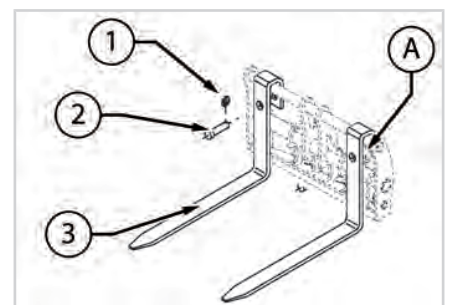

150519-1

**WARNING**

The equipment fastening hole located at the forks end can only be used for fastening certain equipment to the forks. For the fastening procedures refer to the manual of the equipment.

---



**9.6.3 - Installation**

The procedure for installing the forks is the same for installing the equipment, but the safety pins locking system is different.

To secure the forks to the attachment holding plate:

- Remove the snap pins "1" (fig. 150507-1) and the locking pins from the forks "2".
- Place the equipment on a flat not yielding surface, to be able to smoothly engage it with the attachment holding plate of the vehicle.
- Place the vehicle with the boom lowered parallel to the tool. Approach the attachment holding plate to the accessory extending the telescopic boom. The vehicle can not extend the boom if it is completely lowered. Slightly raise the boom to be able to extend it.
- Using the tilting movement, rotate the attachment holding plate downward. Bring the top of the plate under the locking hooks of the tool.
- Slightly lift the boom and rotate the attachment holding plate upwards, thus making the equipment adhere to the attachment holding plate of the vehicle. During this operation, make sure that no person is in the vicinity of the equipment or the vehicle boom.
- Turn off the engine and get out of the vehicle.
- Insert the safety pins "2" in their seats on the attachment holding plate, passing through the corresponding slots of the equipment.
- In the case the two holes do not match, perform the steps described in chapter "Safety pin outline"
- Fit the safety plug "1" on the pins just inserted.
- In the event that the equipment needs electrical or hydraulic connections, refer to the "Hydraulic pipes connection" and "Electrical cables connection" chapters.
- Once properly fixed the equipment, turn on the vehicle and set the correct mode of operation of the vehicle related to the newly installed equipment:
- Consult the use and maintenance manual of the vehicle to set the correct mode of use.
- Check that in the cab there is the load chart related to the vehicle and to the equipment just installed.

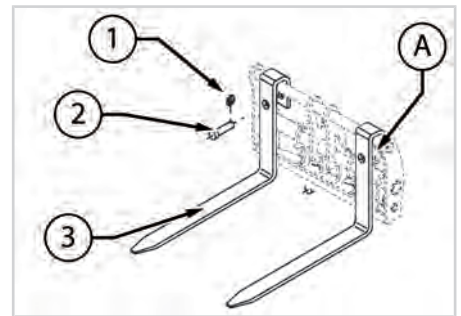

150507-1

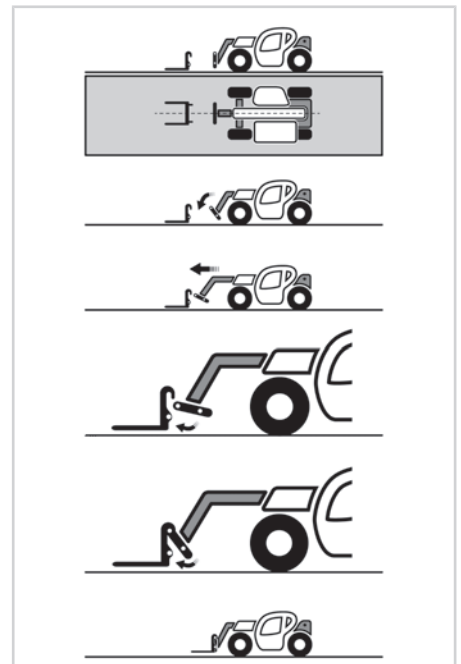

150507-2

## 9.6.4 - Forks check

**NOTE**

For the forks verification frequency refer to the "Control log".

**ATTENTION**

During maintenance and control, it is mandatory to use the appropriate Personal Protective Equipment.

**WARNING**

**It is absolutely forbidden to carry out maintenance on the forks (e.g. welding, drilling, engraving, etc.).**

In the event of damage or deformation immediately replace the forks.

Check the forks thickness.

The maximum wear allowed is **10%** (fig. 150520-1).

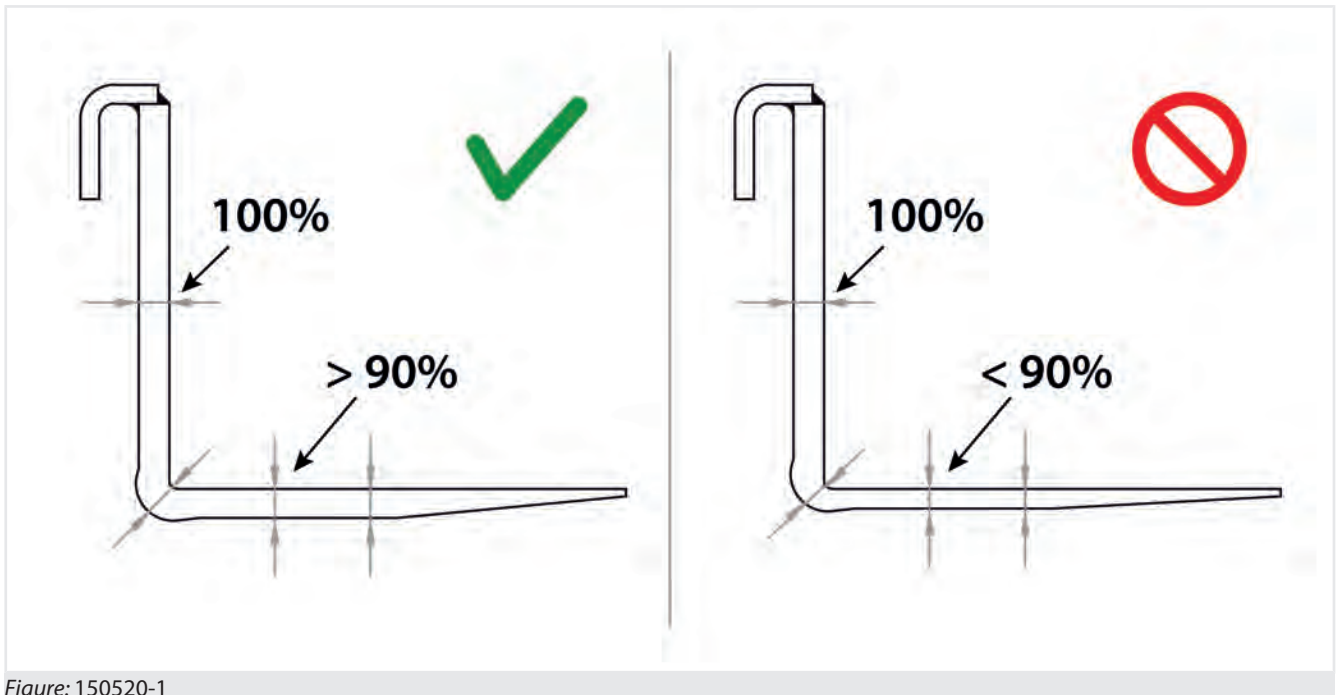

Figure: 150520-1

For example for a fork 70 mm thick, the thickness must not be less than 63 mm. ( $70 - 10\% = 63$ )

For a quick check of the thickness of the forks, it is necessary to measure the thickness in the vertical part of the fork "1" (fig. 150520-2); this will be the dimension to which refer for the fork thickness measurements "2" (fig. 150520-2). Make at least three measurements at several points.

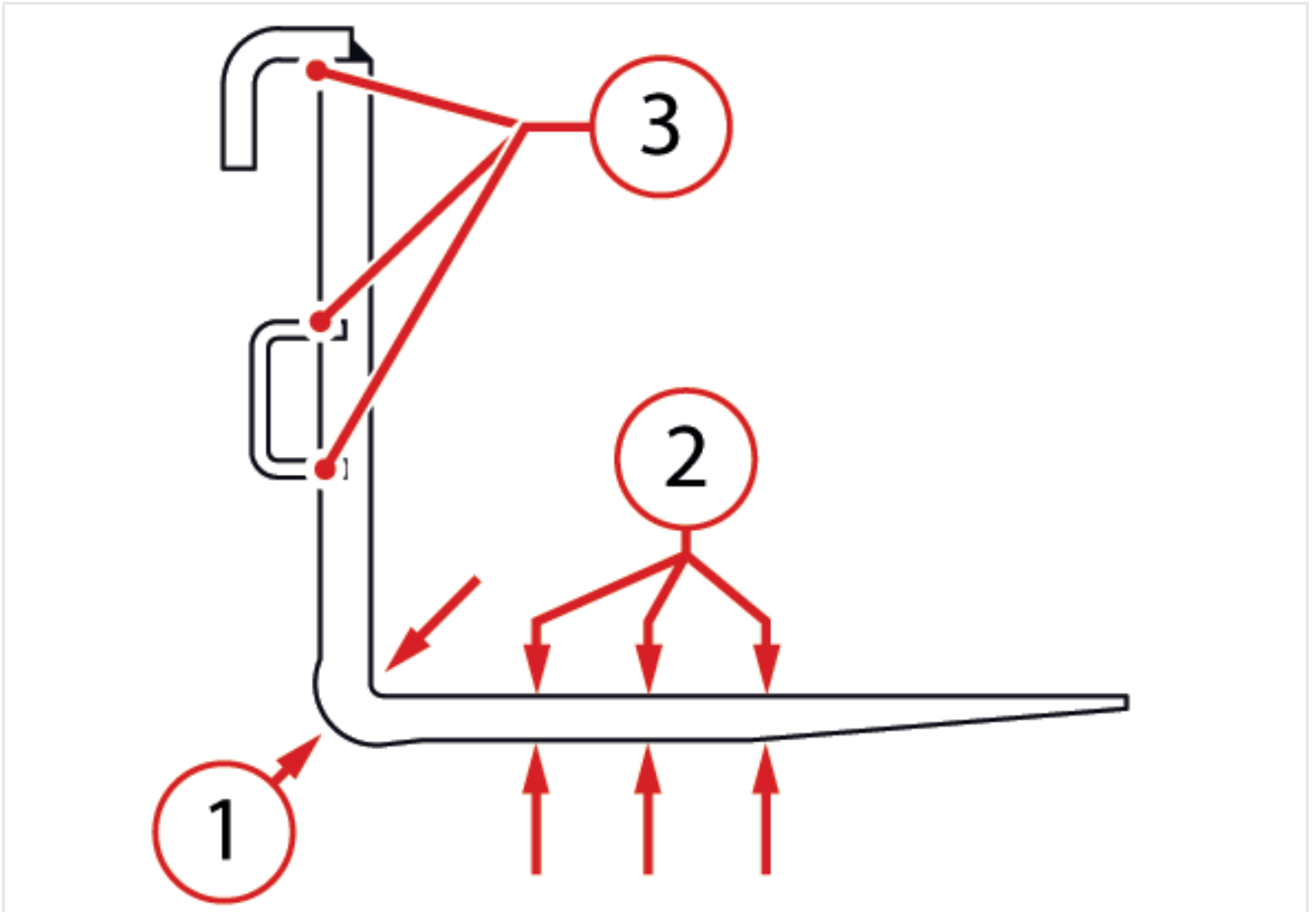

Figure: 150520-2

**Verify the deformation of the forks**

Verify that the two forks are parallel between them and that the distance from the ground is the same for both, or with difference of less than **3%** of the length of the fork (fig. 150520-3).

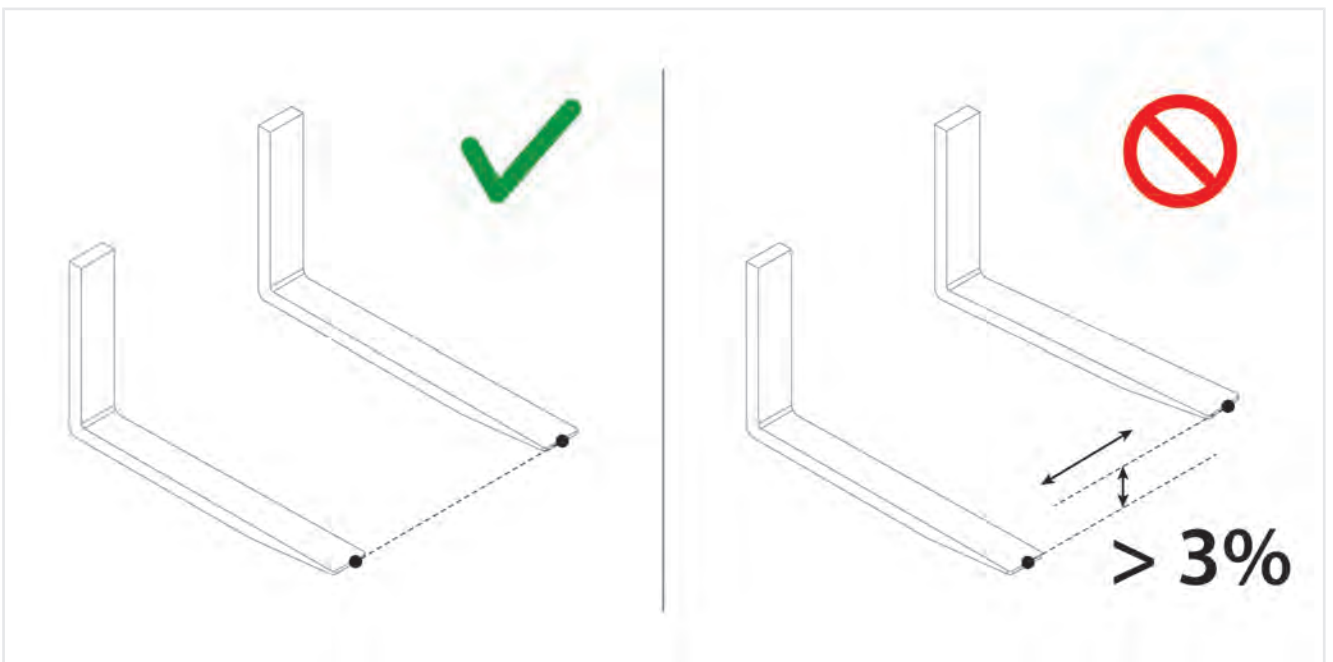

Figure: 150520-3

For example, for a fork 1800 mm long, the difference between the maximum permissible deformation of the fork tips will therefore be of 54 mm ( $1800 \times 3/100 = 54$ ).

## Check the integrity of the welds

Check that all the welds on the forks "3" (fig. 150520-2) are in good conditions and have no cracks or anomalies.

### 9.6.5 - Forks use



#### ATTENTION

Before starting to use the equipment, inspect and test it as described in the section "Equipment pre-use check".



#### WARNING

It is absolutely forbidden to use the forks or any type of equipment, without securing it to the attachment holding plate with the appropriate safety plugs.



#### DANGER

**Before each use, check the wear status of the forks, they could be worn out and not hold the load to be handled creating a dangerous situation.**

Before starting to use the equipment, refer to the chapters:

- a) "Safety regulations"
- b) "Forks safe working procedures [▶ 150]"
- c) "Forks check [▶ 144]"

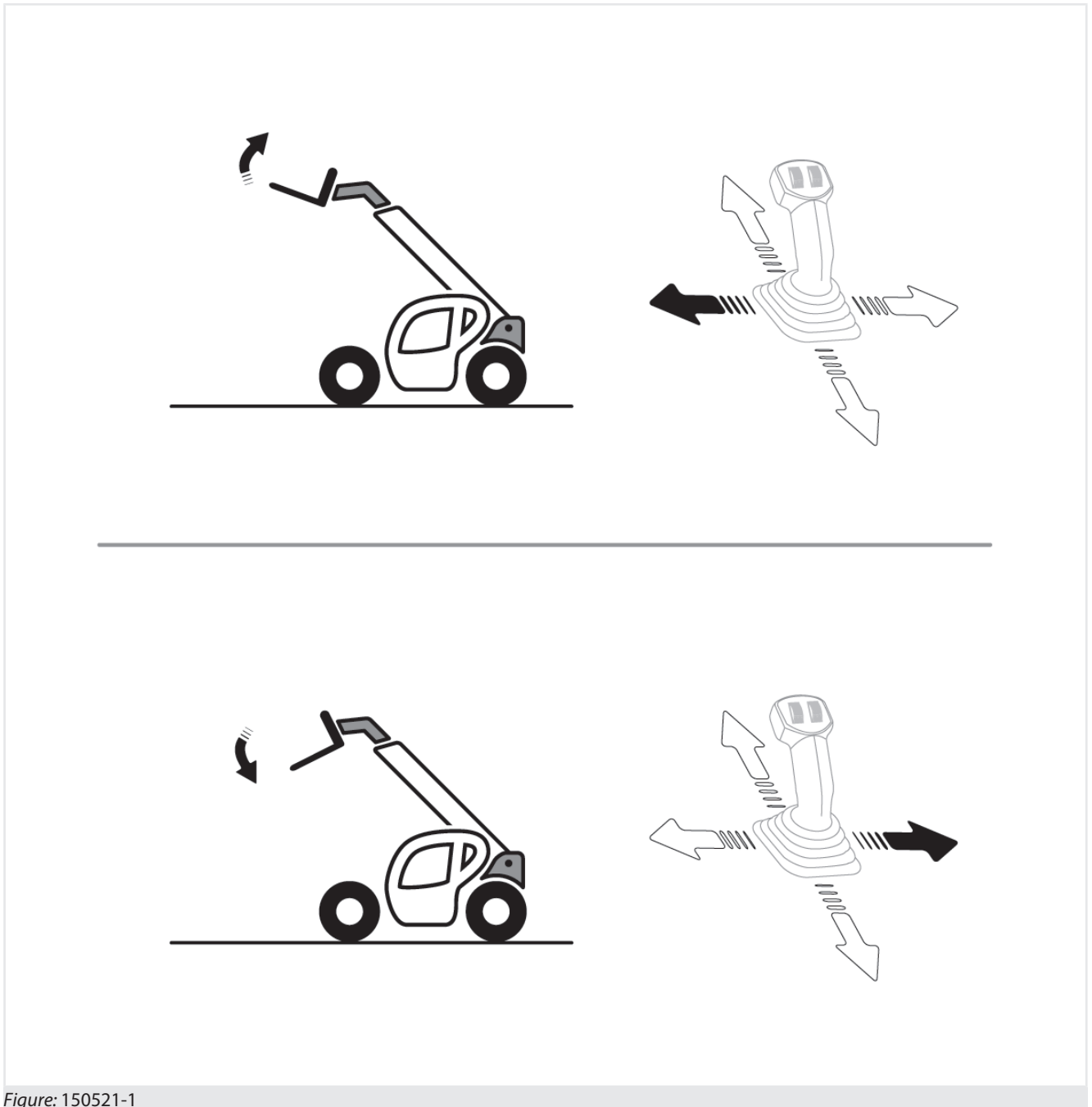

Figure: 150521-1

To use the forks it is sufficient to move the controls for the plate tilting.

By moving the joystick to the left, the tips of the forks will rise; by moving the joystick to the right, the tips of the forks will drop.

### 9.6.6 - Forks adjustment

To adjust the position of the forks it is necessary to:

- Deposit a load to the ground.
- Lower and fully retract the boom moving the forks to about 1 m above the ground.
- Turn off the vehicle.
- Get off the vehicle and manually move the forks to the desired width.

## 9.6.7 - Fork extensions

**ATTENTION**

**Before starting to use the equipment, inspect and test it as described in the section "Forks Safe Working Procedures".**

Before starting to use the equipment, refer to the "Safety regulations" and "Safe Working Procedures" described in the manual of the vehicle on which the equipment is installed.

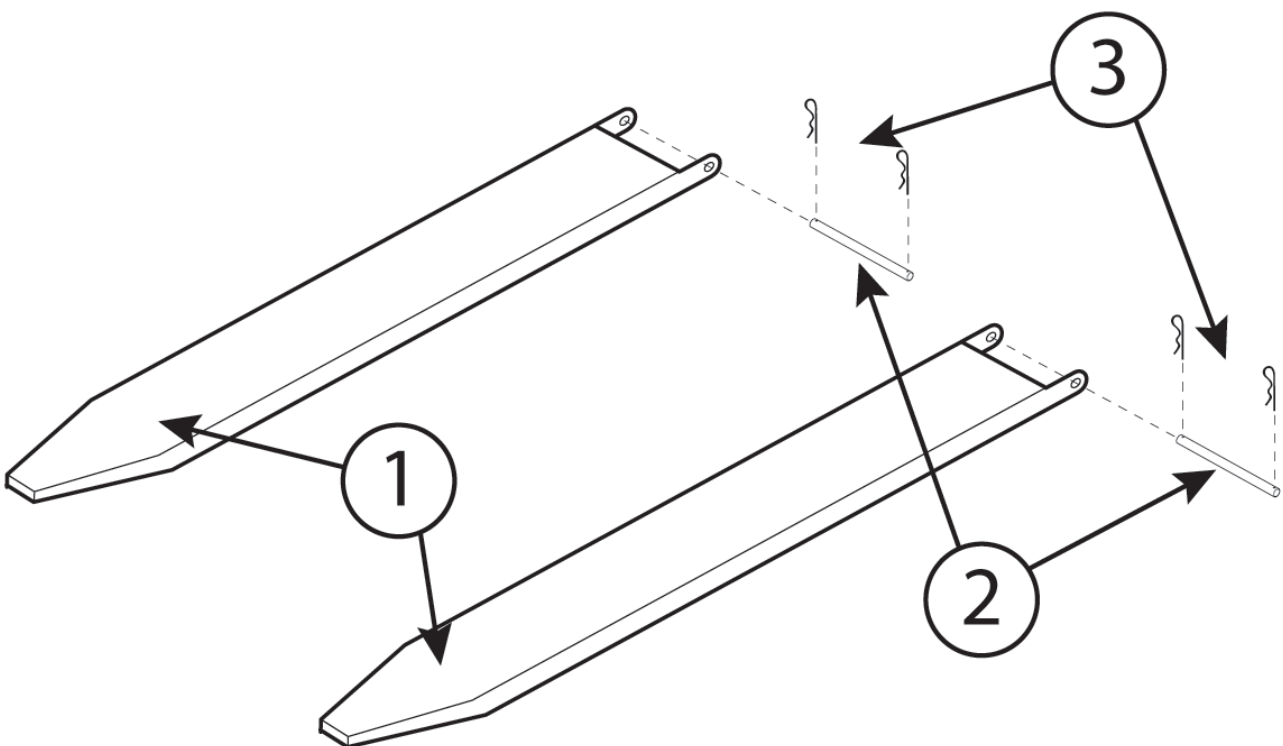

Figure: 150521-1

The fork extensions consists of the following main components (fig. 150521-1):

1. Extension
2. Fastener pin
3. Safety plug



## Warnings for use

- Use the extensions only with the forks for which they were constructed.
- Before use, check their integrity.
- Always apply the pin with the related cotter pin.
- Do not use loads exceeding those indicated by the forks on which the fork extensions are mounted.
- Refer to the load chart of the forks to which are applied the fork extensions.
- Make sure of the load stability.
- Do not take the load with a single extension.
- Do not use extensions for purposes other than those for which they were constructed.

## Installation

- Fit the extension on the forks after establishing the integrity of the extension and the forks.
- Put the fastener pin "2" with the related safety plug "3".



### **DANGER**

Never use if the forks or the extensions if they are defective or show tampering signs.

## Forks extension check

- At each use check the integrity of welds and repair if necessary.
- When the thickness of the lower metal sheet reaches 80% of its original thickness, the extension must be replaced.

## 9.6.8 - Forks safe working procedures

### 9.6.8.1 - General instructions on forks use



#### DANGER

#### Never lift a load slung with a single fork or with a board.

It is absolutely forbidden to use the forks with hooks, straps or other materials for handling suspended loads. Use the appropriate accessories (hook, winch, jib).

- Always set the forks fully under the load and move it to the transport position (forks at 300mm from the ground and tilted backwards, with fully retracted boom).
- The load diagrams are valid for centers of gravity indicated on the diagram. For a center of gravity at a greater distance, contact your dealer.
- Pay attention to the risk of crushing limbs when adjusting the forks manually.
- It is absolutely forbidden to increase the length or width of the forks with extensions not provided directly by the Manufacturer. In this case DIECI is raised from any responsibility regarding their use.
- Forks overloading and transverse stress are strictly prohibited.
- Place the forks to their maximum possible width depending on the load to be moved. Before lifting a load make sure that the width of the forks corresponds to that of the pallet or that these can withstand the weight of the load on the pallet. Forks set wide apart maintain a stable load.
- Place loads evenly on the forks, to obtain a stable balance. When lifting wide loads, or not centered and that are impossible to center, maneuver the vehicle with caution in order to prevent this from tipping. Use caution when lifting bars of considerable length.
- Do not raise the load with the tip of the forks facing downwards. The forks must always be with the tips pointing upwards; in this way the load will lean against the plate of the forks. A lifted load can be tilted forward only if it must be placed on a stack or directly on a discharge surface.
- Do not use the vehicle to transport or move persons when the forks are assembled on it. Use suitable interchangeable equipment approved by Dieci.

### 9.6.8.2 - Load transport position with forks



Figure: 150527-1

To correctly transport a load with forks it is necessary to:

1. Fully retract the boom.
2. Lower the boom fully down so that the forks are at about 300 mm from the ground.
3. Tilt the fork tips upward.

### 9.6.8.3 - Picking up a load from the ground

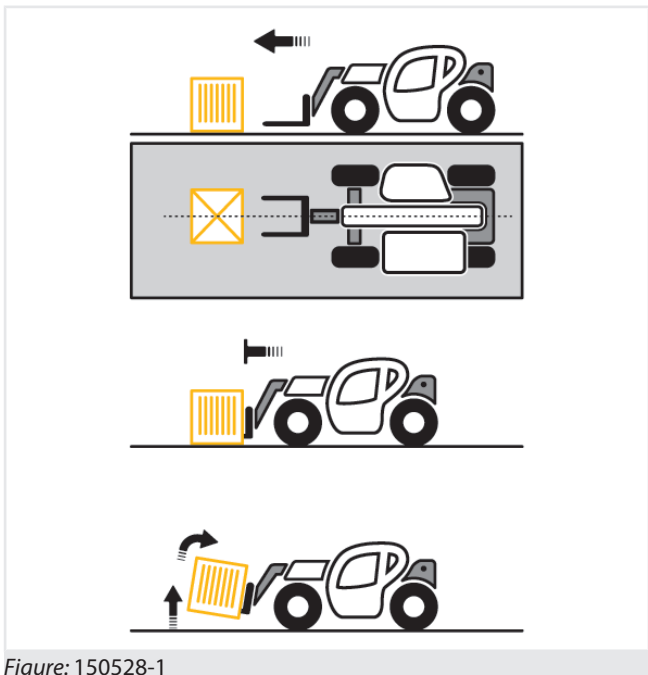

Figure: 150528-1

1. Slowly move the vehicle to the load to be lifted with the boom fully retracted and the forks in a horizontal position at the height of the lifting position. Keep the forks raised just enough to avoid contact with the ground.
2. Bring the forks under the load to be lifted up to the contact with the attachment holding plate.
3. Press the brake pedal and move the gear selector in neutral.

4. Slightly lift the load and tilt the attachment holding plate backward setting it in the transport position.



**WARNING**

Always observe the centre of gravity of the load, tilt the forks enough to ensure stability and prevent the loss of the load during braking.



**DANGER**

Never carry a load with boom raised and/or removed.

9.6.8.4 - Picking up a load from a high position

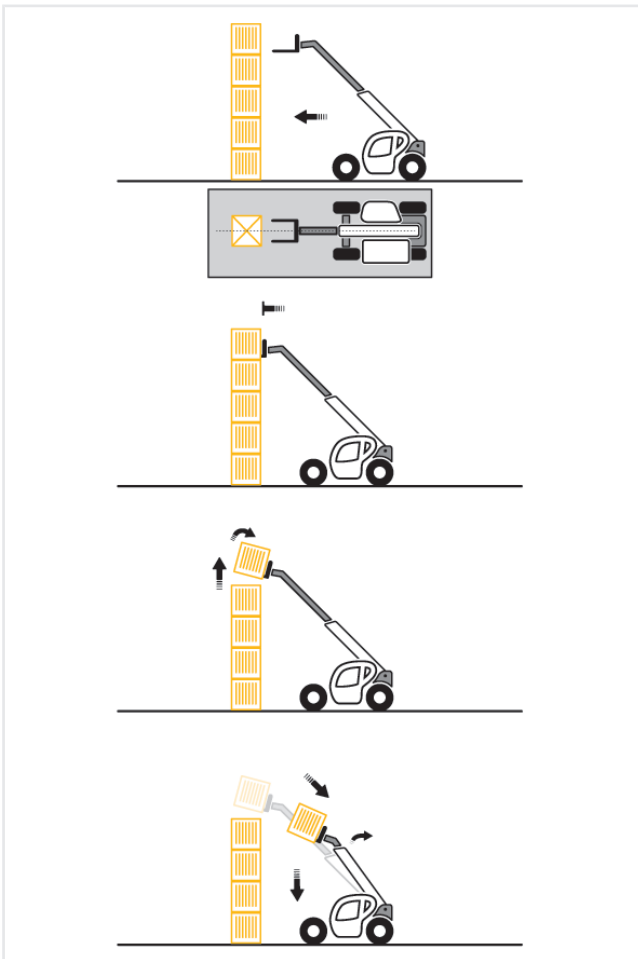

Figure: 150529-1

1. Make sure that the forks pass easily under the load.
2. Drive slowly and cautiously approaching the vehicle to the load placing it perpendicular to this with the forks horizontal. If necessary, use the inching pedal to approach slowly.

3. Always remember to keep the distance required to insert the forks under the load, between the stack and the vehicle.
4. Extend the boom for the shortest possible length.
5. After bringing the forks under the load to be lifted until it is in contact with the fork holding plate, press the brake pedal and move the gear selector in neutral.
6. Lift the load and tilt the fork holding plate to the transport position.
7. If possible lower the load without moving the vehicle.
8. Lift the boom to move the load away, then retract the extensions and lower the boom to set the load in the transport position.
9. If not possible, move the vehicle backward very slowly and very carefully, after moving the load away properly retract the extensions and lower the boom to set the load in the transport position.



**WARNING**

Always observe the centre of gravity of the load, tilt the forks enough to ensure stability and prevent the loss of the load during braking.



**DANGER**

**Danger of tipping**

It is absolutely forbidden to pick up a load if the vehicle is not level.

Never carry a load with boom raised and/or removed.

### 9.6.8.5 - Positioning a load in a high position

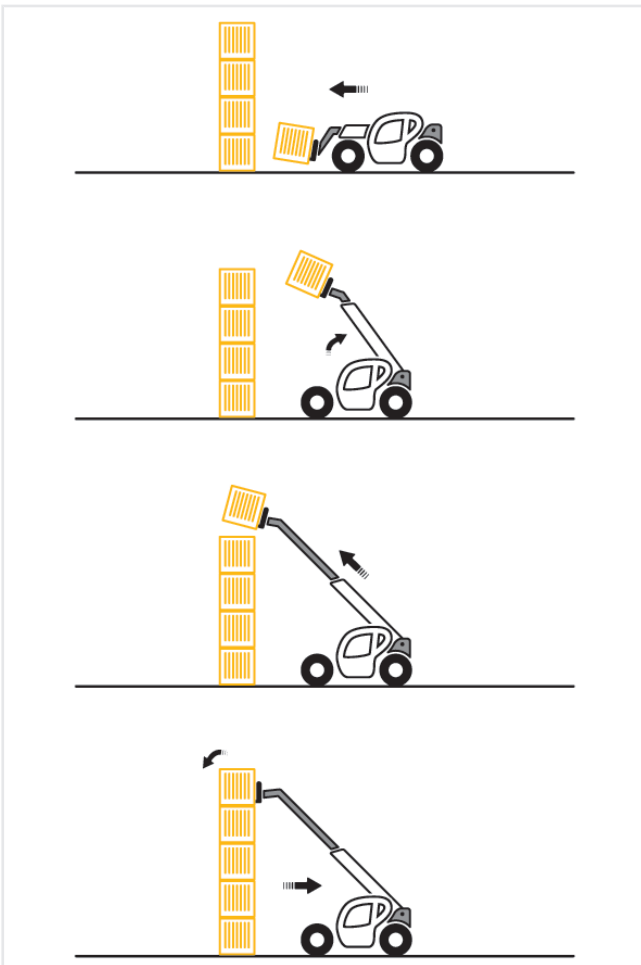

Figure: 150530-1

1. Bring the load in the transport position in front of the stack.
2. Lift and extend the boom to take the load above the stack. If necessary, move the vehicle towards the stack very slowly and very carefully. If necessary, use the inching pedal to approach slowly.
3. Press the brake pedal and move the gear selector in neutral.
4. Place the load horizontally and lay it on the stack, lower and retract the extensions to properly position the load.
5. Release the forks alternately retracting the extensions and lifting the boom; if possible make the vehicle move back very slowly and very carefully.



### WARNING

Always observe the centre of gravity of the load, tilt the forks enough to ensure stability and prevent the loss of the load during braking.



### DANGER

#### Danger of tipping

It is absolutely forbidden to pick up a load if the vehicle is not level.

Never carry a load with boom raised and/or removed.

### 9.6.8.6 - Picking up a round load

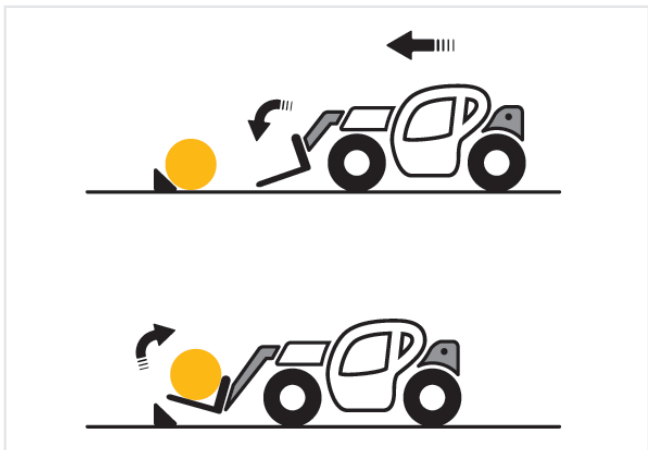

Figure: 150531-1

1. Tilt the forks forward and retract the telescopic boom, while inserting the forks under the load.
2. Rotate the fork carrier plate backward to slide the load. If necessary secure the load with wedges.



### WARNING

Always observe the centre of gravity of the load, tilt the forks enough to ensure stability and prevent the loss of the load during braking.



### DANGER

Never carry a load with boom raised and/or removed.



### NOTE

There are various interchangeable equipment such as grippers to facilitate the work with objects which are round, contact your DIECI dealer.

## 9.7 - Bucket

### 9.7.1 - Buckets identification

Buckets allow handling inert material.

To ensure a prompt and efficient service when ordering parts or when requesting information or technical clarification always specify the serial number.

Therefore we recommend to note the data relating to the accessory in your possession in order to safely and quickly identify them in the future, in case of need.

The data necessary for the identification of the buckets are positioned on the right side, in the upper part "A" (fig. 150522-1).

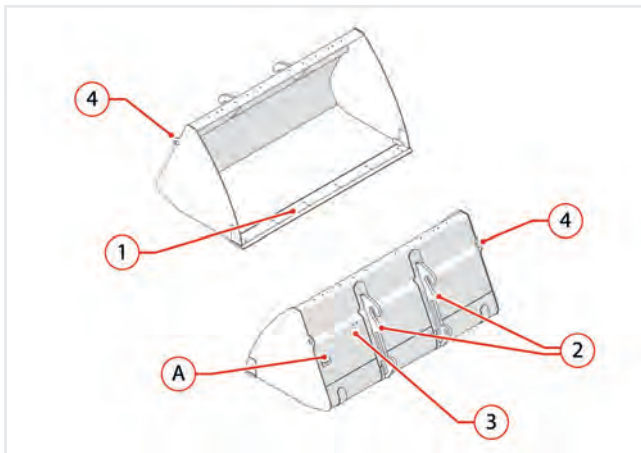

Figure: 150522-1

### 9.7.2 - Buckets description

All the buckets (fig. 150522-1) consist of the following components:

1. Blade
2. Hooks for plate connection
3. Tilt indicator
4. Hooks for lifting

### 9.7.3 - Buckets safety stickers

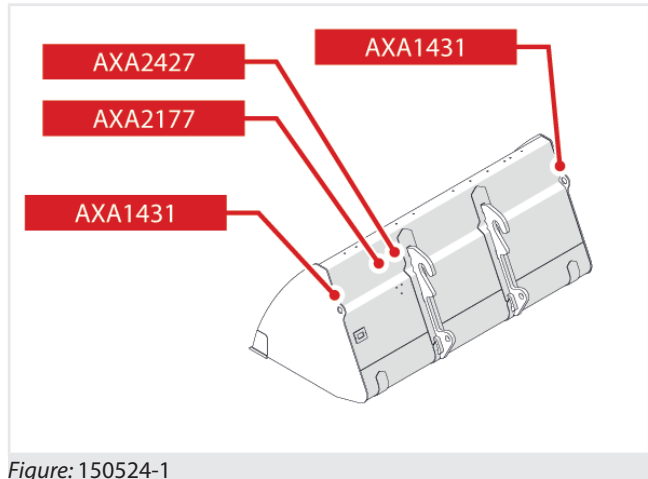

Figure: 150524-1

Safety stickers on buckets (fig. 150524-1):

- AXA2427 – Keep the safety distance from the equipment
- AXA2177 – Read the use and maintenance manual.
- AXA1431 – Lifting hook

### 9.7.4 - Bucket use



#### WARNING

**Before starting to use the equipment, inspect and test it as described in the section "Equipment pre-use check".**

It is absolutely forbidden to use the forks or any type of equipment, without securing it to the attachment holding plate with the appropriate safety plugs.



#### DANGER

Before each use, check the wear status of the equipment, they could be worn out and not hold the load to be handled creating a dangerous situation.

Before starting to use the equipment, refer to the chapters:

- a) "Safety regulations"
- b) "Buckets Safe Working Procedures [▶ 155]"
- c) "Equipment pre-use checks [▶ 127]"



## ATTENTION

Set the appropriate working mode of the vehicle during the bucket use. If this is not done properly, the anti-tipping device could start up and the movements will consequently stop during the bucket excavation or the loading.

To use buckets with Pegasus model vehicles, it is necessary to select the equipment on the anti-tipping device (fig. 171070-1). For the load charts of the Pegasus vehicle when using the bucket, refer to the fork diagram. Extending the boom beyond the letter "A", the loads are halved with respect to those shown on the fork diagram.



171070-1

To use the buckets it is sufficient to move the plates tilting controls.

Moving the joystick to the left, the tip of the bucket will move up; moving the joystick to the right, the tip of the bucket will move down.

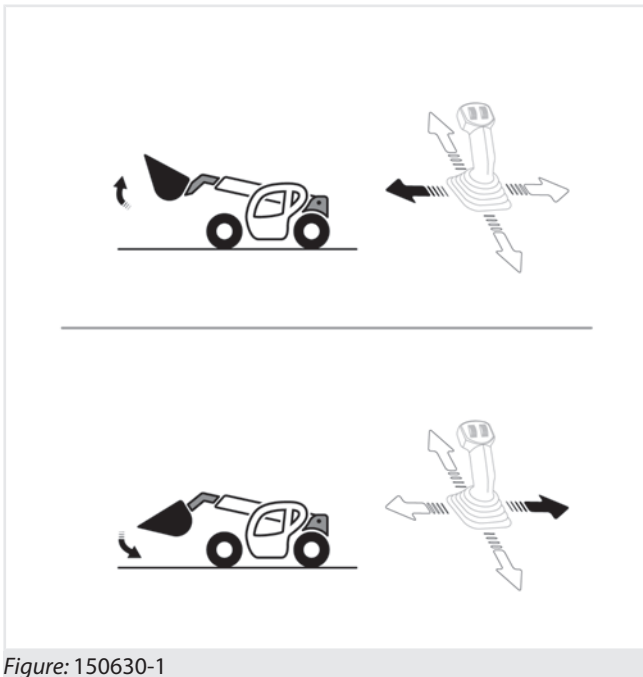

Figure: 150630-1



## WARNING

Given the large size of the buckets, for some movements it will be necessary to remove the boom to prevent contact of the bucket with other parts of the vehicle. It is advisable to operate with the minimum possible extension of the boom.

## 9.7.5 - Fixed tilt indicator use

In the left part of the bucket there is the fixed tilt indicator (fig. 161030-1), this tool allows to know the angle of the bucket during use.



Figure: 161030-1

The bucket position can be determined based on the face shown by the fixed tilt indicator:

- **Upper visible face:** the bucket blade is turned upward
- **Face parallel to the ground:** the bucket is aligned to the ground
- **Lower visible face:** the bucket blade is turned downward

During the bucket loading phase, to obtain the maximum efficiency of the bucket it is appropriate to use the bucket aligned to the ground.

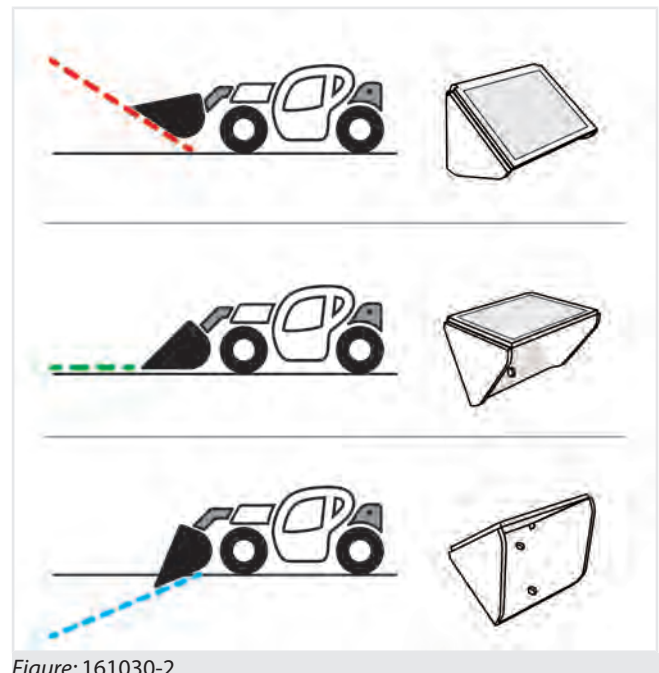

Figure: 161030-2



9.7.6 - Movable tilt indicator use \*



**NOTE**

The movable tilt indicator is an optional accessory.

In the left part of the bucket there is the movable tilt indicator (fig. 161031-1), this tool allows to know the angle of the bucket during use.

It is composed of a pendulum "1" and by two indicators "2".

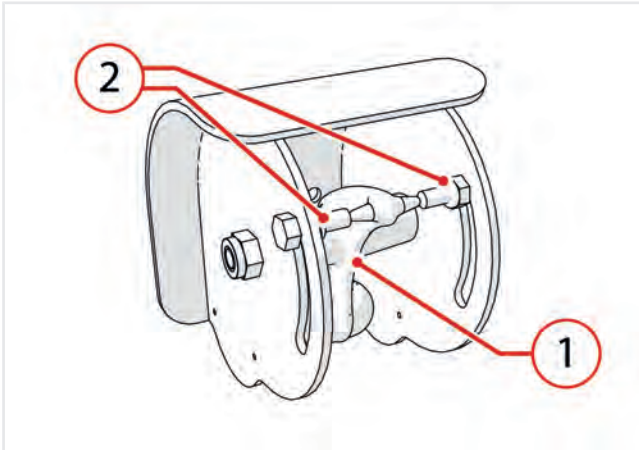

Figure: 161031-1

The bucket position is determined according to the position of the pendulum "1" compared to the indicators "2":

- **Pendulum above the indicators:** the bucket blade is turned upward
- **Pendulum at indicators level:** the bucket is aligned to the ground
- **Pendulum below the indicators:** the bucket blade is turned downward

During the bucket loading phase, to obtain the maximum efficiency of the bucket it is appropriate to use the bucket aligned to the ground.

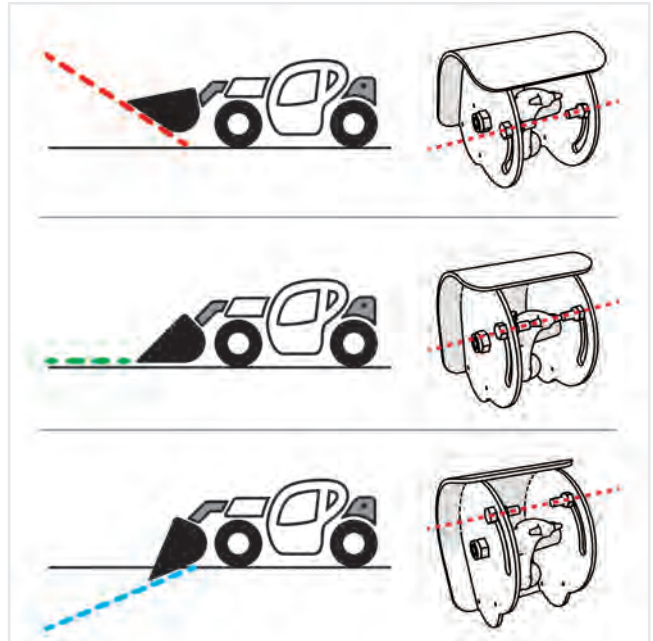

Figure: 161031-2

9.7.7 - Buckets Safe Working Procedures



**DANGER**

Do not change the structure of the equipment.



**DANGER**

Do not use the equipment for lifting persons, animals or things other than those specified.

9.7.7.1 - Checks before lifting

Before starting the operations, perform these checks and inspections to ensure greater safety for operators.

- Positioning of the machine and ground conditions.
- Check the dimensions and characteristics of the work area and complete visibility of the load and of the surrounding area. Otherwise use a person on the ground assigned for signaling.

9.7.7.2 - Danger zones

The danger zones of the vehicle can be identified in the work area of the vehicle and of the bucket.

This area varies in size depending on:

- Load characteristics and size
- Load lifting height

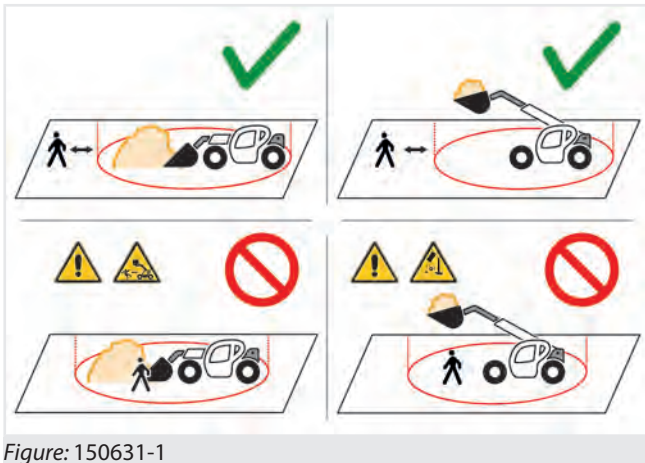

Figure: 150631-1



**DANGER**

Keep away from the vehicle during operation and from the aggregates to be moved, or from the excavation.

**9.7.7.3 - Bucket load**

It is strictly forbidden to push or stack inert material with extended boom. It can cause serious damage to the vehicle.

It is strictly forbidden to push or stack material using the boom extension. It can cause serious damage to the vehicle.

It is strictly forbidden to make levelling or digging operations in reverse. It can cause serious damage to the vehicle.

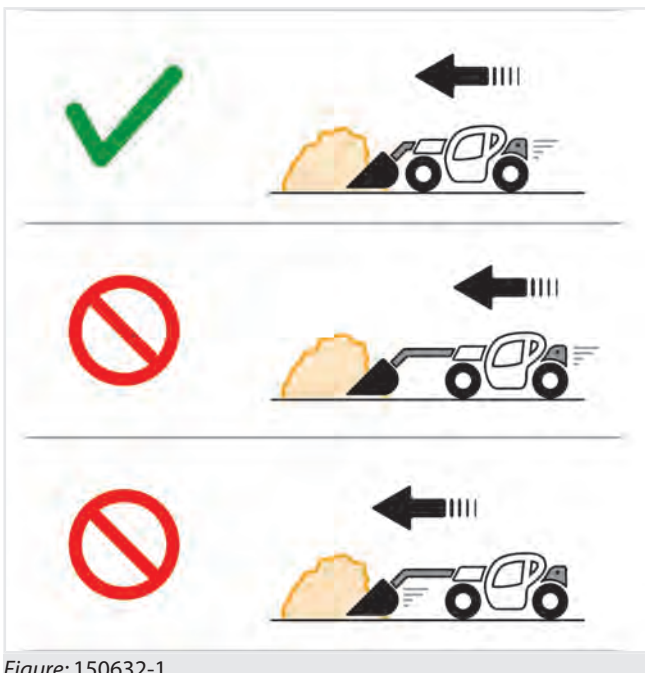

Figure: 150632-1

It is strictly forbidden to push or stack material with the vertical bucket planted in the ground.

**9.7.7.4 - Bucket unloading**



**WARNING**

It is strictly forbidden to repeatedly beat the swinging cylinder at closing limit switch to detach material attached to the bucket.

It can cause serious damage to the vehicle



Figure: Vertical bucket use

**9.7.7.5 - Carry a load with bucket**

The correct vehicle movement position with the bucket equipment installed is:

- Bucket as close as possible to the ground
- Boom retracted as much as possible

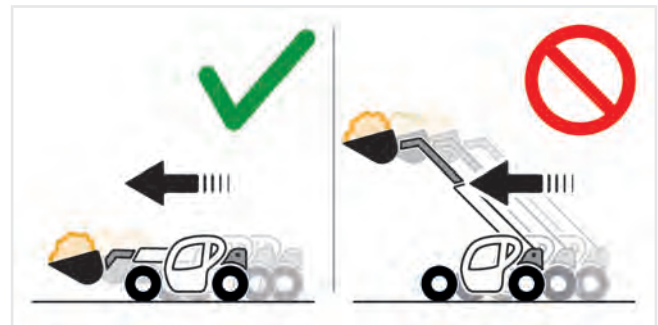

Figure: 150633-1



**WARNING**

It is advisable to keep the bucket at a height sufficient to be able to avoid roughness of the terrain along the way.

## 9.8 - Equipment lifting



### WARNING

**Make sure that the lifting device is adequate for the weight of the equipment to be lifted and that each device used for lifting and every accessory used is CE marked.**

Make sure that the ropes, chains, straps and hooks are in good condition and with capacity adequate to the weight of the equipment to be lifted.

The weight of the equipment is shown on a special riveted metal plate; check the overall dimensions for the maximum and minimum height values from the ground and the weight allowed.

Position the hooks into the lifting holes located at the top, at the centre of gravity of the equipment.



### DANGER

**It is absolutely forbidden to transport the vehicle with the equipment still installed on it.**



### DANGER

**It is absolutely forbidden to transport the vehicle with the equipment still installed on it.**

For details on the procedures to be followed during transport of the vehicle, refer to the Use and Maintenance Manual of the vehicle on which the equipment will be installed.

## 9.9 - Equipment transport



### WARNING

**Make sure that the capacity of the means of transport is adequate for the weight of the equipment to carry.**

When loading or unloading an equipment from a means of transport, there is always the danger of vehicle overturning.

Use a truck or a trailer suitable for transport of the equipment.

When transporting the equipment it is advised to use a support platform for easier handling.

Then fasten the equipment with appropriate slinging systems, check that they are in good condition and appropriate for the weight and dimensions of the equipment.

## 10.1 - Emergency procedure list

<b>Emergency procedure</b>	<b>Additional information</b>
Emergency procedure	7.1.23 Warnings in case of vehicle tipping
	7.2.3 Deactivating the internal parking brake manually
	7.15.6 Manually disable off the 2-gear hydrostatic transmission
	10.2 Vehicle towing
	10.2.1 Vehicle towing with electrical panel on
	10.3 Man basket recovery in case of failure for Hercules
	11.5.6 Start up with auxiliary batteries
	11.5.6.1 Cable connection and engine start-up
	11.5.6.2 Cables removal

## 10.2 - Vehicle towing



### DANGER

**The machine towing is a delicate operation and the risks to the operator are high. The manufacturer's warranty is not applicable in case of incidents or accidents that occur during towing. If possible make repairs where the machine is located.**

It is advisable that the towing operations are carried out by skilled personnel.

#### It is absolutely forbidden:

- Ever try to start the machine by pushing or towing.
- To tow the machine on public roads and for very long paths, if possible keep the yellow flashing light and the emergency lights in operation.
- To tow the machine on a slope.
- Stand between the towing machine and towed machine.



### WARNING

With the engine off the steering wheel and brakes servo controls do not work. If it is not possible to keep the engine running while towing the vehicle take into account that the efforts to use the steering wheel will be much higher than normal.



### ATTENTION

**The machine towing can be made only in emergency conditions at a maximum speed of 4 km/h (2.5 mph) and for short distances up to 500 m (1640 ft).**

To tow the machine over longer distances, contact *Dieci* service center.



### ATTENTION

It is mandatory to tow the machine with a rigid towing bracket. The towing bracket must be designed for a tensile stress of 10 tonnes (22040 lb). Attach the towing bracket between towing vehicle and the vehicle in failure at the points prearranged for towing.



### DANGER

Make sure that the weight of a towed vehicle not equipped with brakes never exceeds the weight of the machine that tows the vehicle. The distance required to stop the vehicle increases with the increase of the speed and of the load towed, in particular in the slope sections.

## 10.2.1 - Vehicle towing with electrical panel on

If it is necessary to tow the vehicle with the electrical panel in operation (for example, transmission failure) follow the following steps:

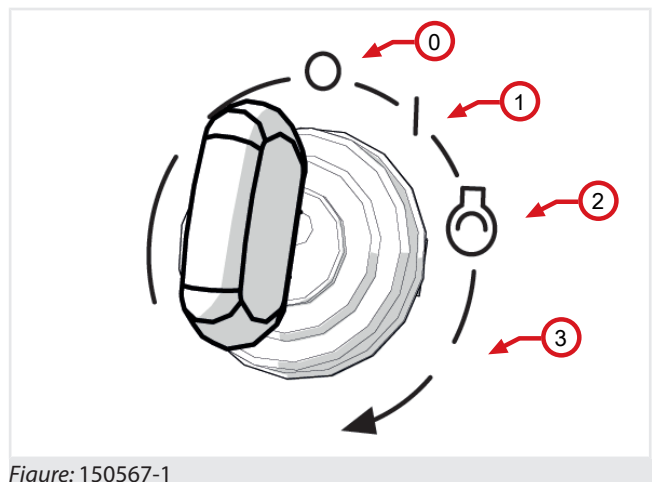

Figure: 150567-1

- Turn the vehicle off by turning the ignition key "0" (fig. 150567-1).

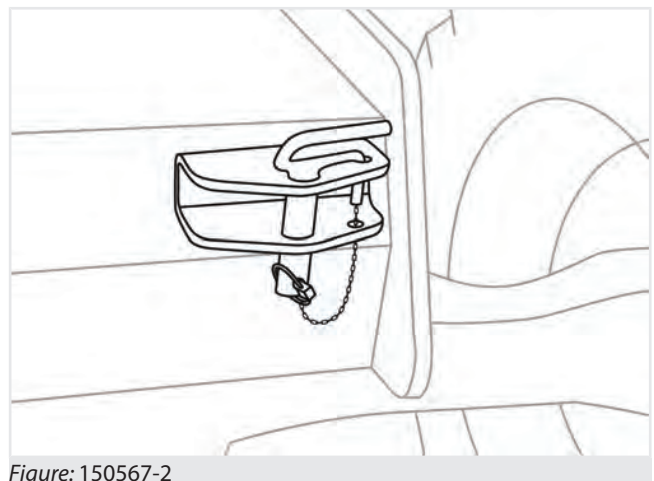

Figure: 150567-2

- Attach the towing bracket between towing vehicle and the vehicle in failure at the points prearranged for towing (fig. 150567-2).
- Make sure that the vehicle is in a stable configuration and lock the wheels with chocks to prevent accidental movement of the vehicle.
- Remove the lower protective casing by removing the screws with a wrench size 13.



- Follow the steps described in the chapter "Manually disable the transmission".
- Switch on the electrical panel by turning the ignition key to position "1" (fig. 150567-1).
- Disengage the parking brake switch.
- Remove the wheels chock.
- During towing, remain seated in the driver's seat to prevent the parking brake from engaging automatically.

### 10.2.2 - Towing the machine with engine in failure

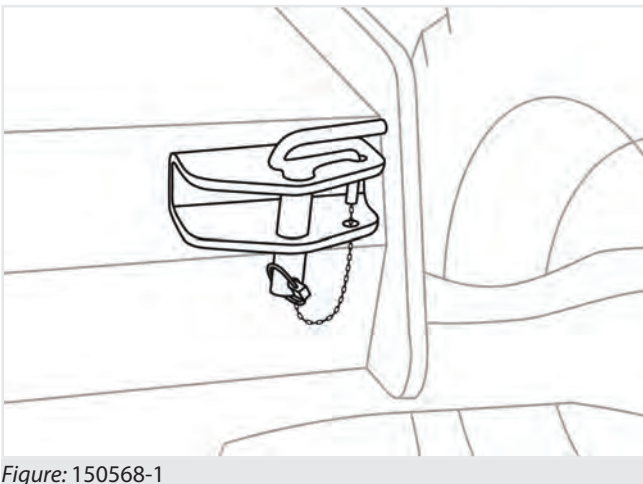

Figure: 150568-1

In case it is necessary to tow the machine with engine in failure, follow the following steps:

- Attach the towing bracket between towing vehicle and the vehicle in failure at the points prearranged for towing (fig. 150568-1).
- Make sure that the machine is in a stable configuration and lock the wheels with chocks to prevent accidental movement of the machine.
- Follow the steps in the section "Manually disable the parking brake on the vehicle front axle".
- Follow the steps described in the chapter "Manually disable the towing".



#### DANGER

**With the engine off, the drive and parking brake are still active.**

Towing the machine with active drive and brake can cause serious damage to the machine and create dangerous situations.

## 10.3 - Man basket recovery in case of failure for Hercules

In the case of lack of motive force during use of the vehicle with man basket, which leads to the man basket locking, it is possible to operate with the manual system to return the boom and the operators on the ground in safe conditions. In order to carry out this emergency operation use the appropriate emergency pump.



#### DANGER

Under the emergency pump use conditions the anti-tipping systems are off. It is compulsory to refer to the load charts (found in the notebook in the cab and on the Use and Maintenance Manual) before performing any operation through the levers of the distributor. In this way it is possible, using the inclinometer and the letters on the boom, to know the exact location of the basket and of the work area within which it can operate. During the basket recovery there must not be no aggravating movements for the stability of the vehicle as there is a risk of tipping.



#### WARNING

Two qualified and experienced operators, authorized by the security officer, are required to complete the retraction operation.



#### DANGER

Do not ever try to get out of the man basket using makeshift equipment or using systems that expose to personal risk.

The operations that can be performed with the emergency pump are:

- Boom retraction
- Boom extension
- Boom lower
- Boom up

To carry out the manual boom retraction, perform the following procedure.

- Turn off the diesel engine.
- Remove the protection housings on the back of the vehicle removing the 4 screws "1" (fig. 150721-1)



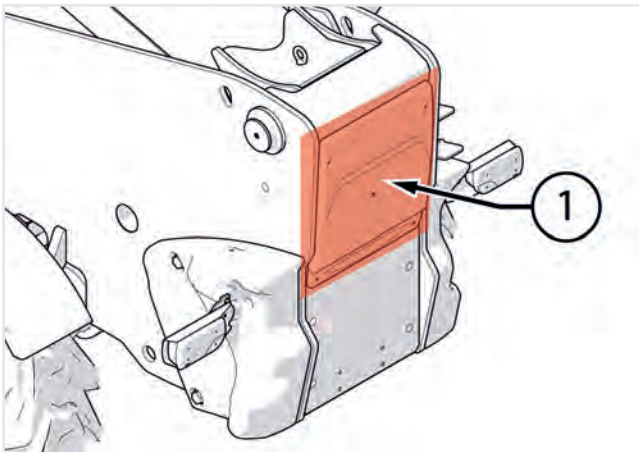

Figure: 150721-1

- Remove the safety clamp from the levers "1" (fig. 150721-2)
- Move the levers "2" (fig. 150721-2) from position A (open) to the position C (closed) (Fig. 150721-3). Only after this operation it will be possible to move the boom using the emergency pump.

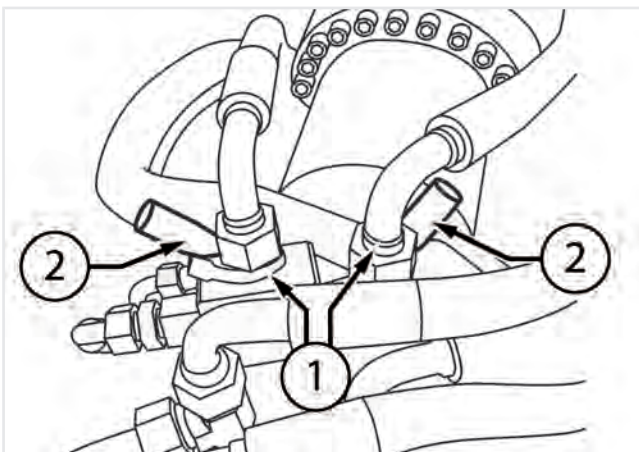

Figure: 150721-2

- **WARNING! At the end of the basket recovery procedure, put the levers in position A.**

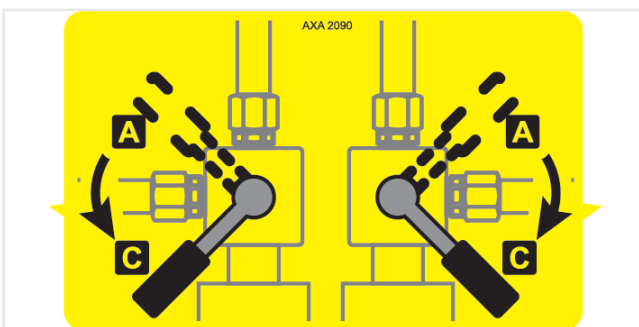

Figure: 150721-3



**WARNING**

Move the basket alternating movements of boom extension, retraction and lowering, always remaining within the load charts values.

- Place the hydraulic pipes according to the diagram shown below to make the desired movement

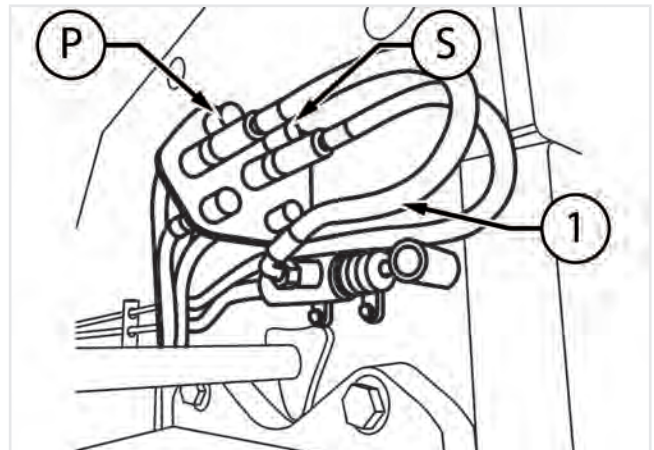

Figure: 150721-4

**NOTE! Always clean the hydraulic contacts before making the hydraulic connections.**

**A - Pipes position for boom up**

Place the hydraulic pipe which comes out from the pump (P) in position A1, and the other pipe (S) in position A2.

**A - Pipes position for boom lower**

Place the hydraulic pipe which comes out from the pump (P) in position A2, and the other pipe (S) in position A1.

**A - Pipes position for boom extension**

Place the hydraulic pipe which comes out from the pump (P) in position B1, and the other pipe (S) in position B2.

**A - Pipes position for boom retraction**

Place the hydraulic pipe which comes out from the pump (P) in position B2, and the other pipe (S) in position B1.

**E - Pipes position for normal working conditions**

Position both hydraulic pipes in position N.

- Pull out the rod placed in the toolbox and insert it into the housing of the emergency hand pump "1" (fig. 150721-4)
- Move the rod in both directions for operating the emergency pump.
- Move the boom so as to always stay within the working diagram.
- When the recovery is completed, put the rod into the toolbox.
- Return the distributor levers "1" (fig. 150721-4) to position A (fig. 150721-5) and secure them again with the clamps.

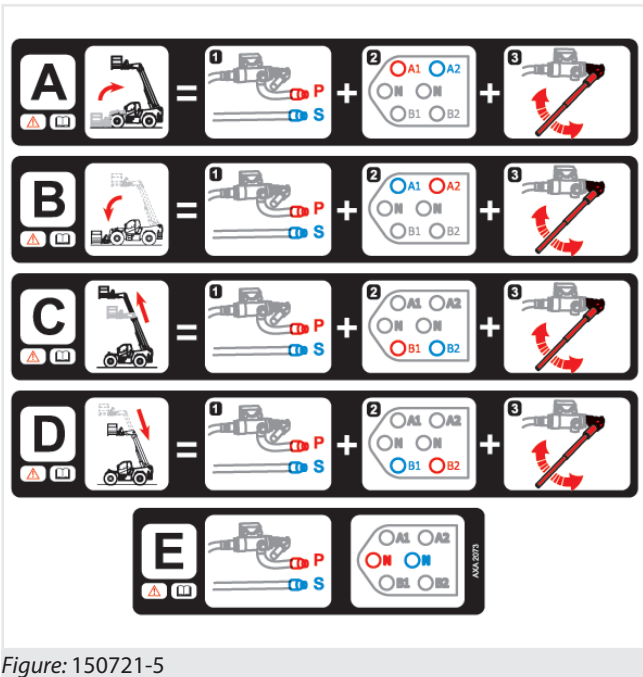

Figure: 150721-5



**WARNING**

**Before performing any maintenance operations set the vehicle in the maintenance position.**

Use appropriate personal protective equipment during the various checking and maintenance operation of the vehicle.



**WARNING**

**It is prohibited to carry out maintenance on the vehicle if this chapter has not been carefully read and learned.**

To learn about maintenance operations and time, refer to the Maintenance Log.

All maintenance operations must be recorded on the appropriate Maintenance Log.

**11.1 - Maintenance warnings**

This vehicle has been designed and built to provide maximum performance, savings and facilitate its operation in various working conditions. Before delivery, the vehicle and the equipment were tested both by the Manufacturer and by the Dealer to ensure their maximum condition. In order to preserve these conditions and to ensure trouble free operation, it is important to perform routine maintenance, as specified in this Manual at a **DIECI** dealer at the frequency required.

This section of the Manual provides all the maintenance prescriptions necessary for maintaining the **DIECI** vehicle in perfect working condition.

It is recommended that all services must be carried out as part of the assistance program recommended by **DIECI**. Remember that the owner and/or user is responsible of keeping the vehicle and equipment in safe operating condition and able to operate.

It should be noted, also, that proper maintenance of vehicle and equipment not only improves reliability, but preserves its value over time.



**WARNING**

When operating in corrosive environments it is important to intervene with appropriate maintenance methods and timing in order to prevent excessive wear of the vehicle.



**ATTENTION**

Use appropriate personal protective equipment during the various checking and maintenance operations of the vehicle.



**WARNING**

In case of malfunction do not use the vehicle until it has been repaired.



**ATTENTION**

**Maintenance or repairs not covered in this chapter and in the rest of the manual should be performed only by *DIECI* Dealers.**

It is mandatory to have read and learned the "Safety" chapter before reading the "Maintenance" chapter.

**11.1.1 - Avoid accidents during maintenance**

- Always clean and tidy the workplace in order to carry out every operation safely.
- Do not leave tools or other instruments scattered in a disorderly manner in the workplace.
- Clean grease traces, oil or other substances that could cause you to slip.
- For the workplace safety put rags soaked with grease and/or other flammable materials in a secure container.
- Use only tools appropriate for the task and make sure to use them in the right way. The use of damaged, poor quality, faulty, makeshift tools or not suitable for use may cause serious injury.
- Do not hit the vehicle and the equipment or their parts with a hammer or any other instrument, as projected fragments could cause injury.
- If inspection or maintenance is carried out on vehicles or equipment which are still covered with mud, oil, etc., operators risk sliding or falling

and the visual analysis of components is made more difficult. Thoroughly clean the vehicle or equipment before every operation.

- Make sure about the maintenance procedures before starting the work.
- Keep the work area clean and dry.
- Replace worn or faulty components.
- Eliminate accumulations of grease oil and debris.
- The knurled plates (bulb plates) and the cab floor are the only parts of the vehicle that can be stepped on. Use a ladder (suitable for the intended purpose) for maintenance of parts that cannot be reached from the ground.



## DANGER

**Do not carry out any maintenance operation with running engine or moving vehicle.**

Should maintenance need to be performed with the engine running, ask at least two workers for help and observe the following instructions:

- One worker must always be seated in the driver's seat, ready to switch off the engine at any time.
- All workers must remain in contact with one another.
- Take care not to remain entrapped in components during the execution of operations performed on the fan, fan belt or other rotating parts.
- Do not touch levers or control pedals. Should a lever or pedal need to be moved, always warn operators first so they can move out of the dangerous area.
- Do allow instruments or other objects to fall into the vehicle rotating parts, as these parts may break and be projected out.
- The vehicle must be outdoors when the engine is running. The vehicle can be kept in a closed area only if it is properly ventilated and the vehicle is equipped with specific purifiers.



## WARNING

**In the case of operations to be performed by holding the boom raised, install the safety rod on the boom shaft.**

If you need to perform repair or maintenance work under the vehicle, firmly support the movable parts with blocks and supports that are solid enough to support the weight.

- Store attachments removed from the vehicle in a safe place where they do not risk falling. Take precautions to prevent unauthorized persons from approaching the storage area.



## DANGER

Do not rest metal parts on the battery.



## DANGER

**Danger of entanglement.**

Damage may be caused by entanglement in moving parts. To prevent accidents it is compulsory to wear proper safety equipment for maintenance.



## DANGER

**Exhaust gas danger**

Exhaust engine gases are toxic and can damage your health.

The vehicle must be outdoors when the engine is running.

The vehicle can be kept in a closed area only if it is properly ventilated and the vehicle is equipped with specific purifiers.



## DANGER

**Pressurized liquids danger**

After operation, the engine cooling liquid is hot and under pressure. Contact with hot water and/or steam may cause serious burns.

- Do not attempt to loosen connections, tubes or hydraulic components when circuits are under pressure.
- Avoid possible injury caused by hot water jets.
- Do not remove the radiator cap until the engine has cooled down.
- Before removing the cap, release all of the pressure.
- Prevent burns caused by oil or other hot parts during inspection or discharge by allowing the oil and cap to cool down before beginning operation.
- Even after the oil has cooled down, slightly loosen the cover or cap before removing it to mitigate pressure inside.



**DANGER**

**Burns danger**

Attention to burns. Engine reduction gear oil and the hydraulic system, pipes, engine and other components heat up when the vehicle is used. Wait until all parts cool down before beginning maintenance or repair work.

- Fluids such as fuel or hydraulic oil under pressure can penetrate the skin and eyes causing serious injuries. Take care to avoid these risks when repairing or doing maintenance work on the vehicle.
- Discharge the pressure (using the hydraulic levers of the distributors) before disconnecting or repairing pipes and hydraulic parts.



**DANGER**

When a hydraulic pipe needs to be disconnected, slowly loosen the fittings to discharge residual pressure.



**DANGER**

**Pressurized liquids danger.**

Hydraulic energy accumulators are mounted on the vehicle. Before intervening on them, make sure to discharge any internal pressure. Danger of high pressure oil splashes.

- Before restarting the engine, ensure that all connections have been properly tightened.
- Use a piece of cardboard to check for any leaks; make sure your body is adequately protected against pressurized fluids.
- Any fluids that penetrate the skin must be removed surgically. Should there be an accident, seek medical attention immediately.



**DANGER**

**Corrosive substances danger**

Never touch air conditioning coolant.

- If it comes into contact with eyes, air conditioning coolant may cause blindness; it may cause freezing if it comes into contact with skin.
- When cleaning with compressed air, serious injury may be caused by flying particles.
- Always wear protective goggles, a dust mask, gloves and other protective equipment.



**WARNING**

**Adjusting and/or dismantling balancing and safety valves can be dangerous.**

One of the above-mentioned valves may be removed only when the concerned jack is at rest and the hydraulic circuit is not under pressure.

All other operations must be carried out by qualified, authorized personnel only.



**NOTE**

Only use lubricants suggested by DIECI; never utilize used lubricants.

**11.1.2 - Personal protective equipment for maintenance**



**WARNING**

Always use the personal protective equipment most suitable to the checking or maintenance operation to be performed.

Icon	Description
	Wear protective goggles <ul style="list-style-type: none"> <li>• Wear protective goggles in case of operations involving the use of compressed air.</li> </ul>
	Wear safety shoes
	Wear protective gloves <ul style="list-style-type: none"> <li>• Wear nitrile gloves in case of operations with grease, hydraulic oil or fuel.</li> </ul>
	Wear protective clothing
	Wear a protective mask





## DANGER

### Danger of crushing

Pay attention to moving parts to avoid danger of crushing or dragging of the lower and upper limbs. Avoid wearing jewellery or pendants that might be trapped in moving parts. Long hair must be tied back to avoid it being caught in moving parts.

Do not wear loose clothing, chains, belts or other accessories that may be caught in the control levers or in other parts of the vehicle.

## 11.2 - Preliminary maintenance operations

### 11.2.1 - Prepare the vehicle in the "Maintenance position"



## WARNING

Before performing maintenance work on your vehicle, do the following:

- Park the vehicle on flat, even ground.
- Engage the parking brake.
- Lower and fully retract all mobile parts (booms, shovels, etc.).
- If the maintenance operation requires the mobile parts to remain up, apply the safety rod.
- Run the engine at a minimum for 60 seconds to cool it down.
- Release residual pressure from the hydraulic system.
- Switch off the key in the ignition switch.
- Remove the ignition key.
- Hang up a sign that indicates maintenance work is underway. This sign can be hung on the cab door and inside it on the controls.
- Set up barriers and spacers to prevent unauthorised personnel from approaching the vehicle.
- Disconnect the battery isolation switch.
- Allow the engine to cool down.

## 11.3 - Engine hood opening



## DANGER

**Do not open the hood with the diesel engine in motion. At the end of the maintenance operations the hood must always be closed and locked.**

Do not work with the engine hood open.

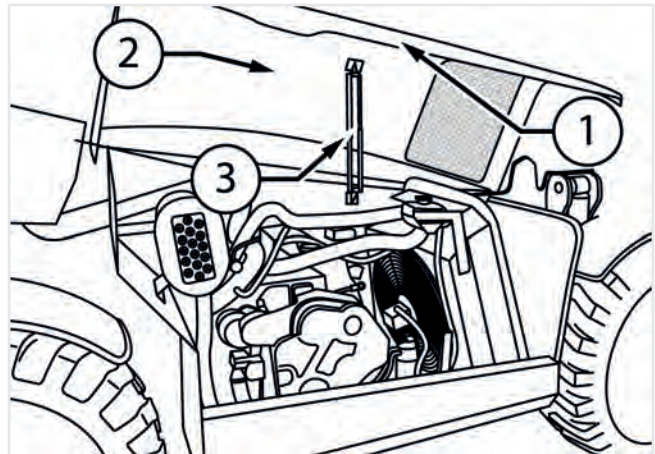

Figure: 150722-1

To open the engine upper hood it is necessary to (fig. 150722-1):

- Turn off the diesel engine.
- Remove the ignition key.
- Place in the cab a sign showing "Maintenance in progress".
- Disconnect the battery using the battery isolation switch.
- Pull the lever "1".
- Lift the hood "2" until the support rod "3" is locked in the open position.
- Release the hood gradually to ensure that the support rod has been inserted correctly.

To close the engine hood (fig. 150722-1):

- Hold the engine hood "2".
- Press the red side of the support rod "3".
- Hold down the red part of the rod "3" and slowly lower the hood "2".
- With the hood partially lowered, release the red side of the rod "3" and fully close the hood.
- Close the engine hood with light pressure. Always check the proper closing before starting to work or before leaving the vehicle.
- Reactivate the battery isolation switch.



## 11.4 - Under chassis protection plate removal

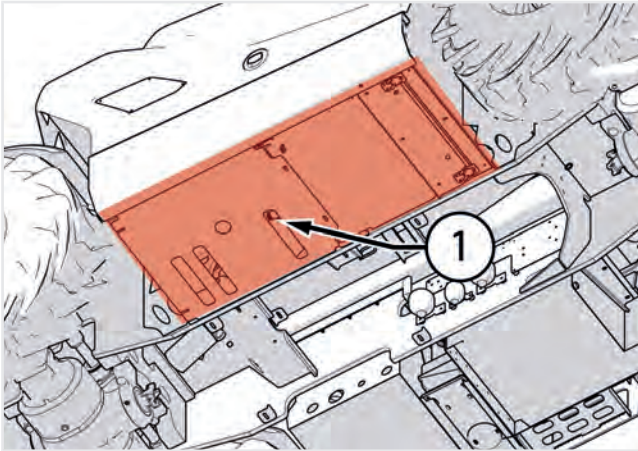

Figure: 150723-1

To perform maintenance operations it is necessary to temporarily remove the under chassis protection of the vehicle. The under chassis protection protects the bottom of the vehicle, from any bumps, collisions, dirt.

**To remove the under chassis protections (fig. 150723-1):**

- Place the vehicle in the maintenance position.
- Lock the wheels with chocks to prevent accidental movement of the vehicle.
- Unscrew the fastening bolts with a wrench size **13** and remove the engine under chassis protection "1".



### ATTENTION

At the end of the maintenance operations refit the under chassis protections.

## 11.5 - Battery



### DANGER

**To avoid the risk of explosion of the batteries:**

- a) Keep sparks, free flames and cigarettes away from the top of the batteries because the gases that they can produce are highly flammable.
- b) Do not charge damaged batteries.
- c) Do not charge a hot battery.



### DANGER



**Batteries contain highly polluting substances that must not be dispersed in the environment.**

Dead, old, damaged, batteries etc. must be properly disposed of.



### DANGER

**The battery contains sulfuric acid electrolyte which is a corrosive substance and must be treated with caution because it can cause poisoning and severe burns.**

Keep out of the reach of children.

Avoid contact with skin and eyes.



### ATTENTION

Wear protective clothing, gloves and safety glasses. In case of contact with eyes or skin, rinse immediately with plenty of water and seek medical attention. If swallowed, contact a doctor immediately.

- Do not overturn or tilt the battery as acid could come out.
- Charge the battery in a well ventilated area and always disconnect the power before removing the terminals.
- To check the charge status always use a voltmeter or a densimeter. If it is necessary to check the electrolyte level, use a flashlight, never a flame.
- Never place a metal object between the terminals to check the battery charge.
- Do not generate sparks with the cable terminals while charging the battery or starting the engine of the vehicle with an auxiliary battery.
- Check that the vent caps or covers are fitted correctly and firmly.
- Clean the top of the battery, check that the terminals are tight and cover them with a thin layer of petroleum jelly.
- In case of frozen battery this should be stored in a warm place to defrost. Do not use and do not recharge it: risk of explosion.
- In normal conditions the battery is kept charged by the alternator of the vehicle. If this becomes completely exhausted due to prolonged disuse or because at the end of its life the alternator

loses its capacity to "regenerate". The battery must be replaced and recharged using a special battery charger tool.



### WARNING

Before performing any maintenance on the vehicle, disconnect the power supply to the electric circuit of the machine by pressing the battery cut-off switch.

## 11.5.1 - Low maintenance batteries

The low-maintenance batteries have been studied to avoid maintenance interventions in ordinary and normal use of the battery. In case of discharge check the electrolyte level. For technical specifications contact the supplier or the manufacturer.

## 11.5.2 - "Zero" maintenance batteries

They are batteries that do not allow maintenance intervention.

When the battery is discharged it must be replaced. For technical specifications contact the supplier or the manufacturer.



### DANGER

Do not carry out maintenance or recovery operations on "zero" maintenance batteries.

## 11.5.3 - Battery: Instructions for recharging

- A battery is fully charged if at constant temperature the density of the electrolyte and the measured voltage at the poles does not increase within 2 hours.
- Each recharge will be good as good are the general conditions of the battery. This means that an old battery, after charging, will not have the same life and efficiency of a new battery.
- The simplest charging method is to charge at constant power.
- At the end of the charging, the battery charger voltage increases and creates gasification. It is recommended to use simple battery chargers with minimum current control and timer.
- If the battery has a low electrolyte level restore it to the minimum level (just above the plates limit) then charge them. After the charging is completed, fill to the maximum level (to prevent leakage).

- Overcharging must be avoided because:
  - It is a loss of energy which causes the dissociation of water.
  - It produces loss of active mass for the electrodes deterioration
  - It creates a risk of explosion.
- If sulfated batteries are recharged without voltage limitation, they will boil and warm up with a risk of explosion.
- For old batteries (in most cases sulfated) charge with great caution. Even with 13.8 Volts there is the possibility of a temperature increase.

Follow these instructions to recharge the battery:

1. Disconnect the cables of the vehicle from the battery to protect the electrical system of the vehicle.
2. Place the battery at a safe distance from the vehicle.
3. If possible, remove the caps.
4. Check the electrolyte level, if possible.
5. Clean the poles.
6. Make sure the room is sufficiently ventilated.
7. Limit the charging current to a maximum of 1/10 of the battery capacity (Ah).
8. Connect the battery to the charger.
9. Connect the charger to the mains.
10. Turn on the battery charger.
11. The battery temperature must not exceed 55°C.
12. After finishing switch off the battery charger.
13. Disconnect the battery charger from the mains.
14. Disconnect the battery from the charger.
15. Check the electrolyte level, if possible.
16. Refit the caps.

## 11.5.4 - Battery isolation switch



### WARNING

Use this switch only when the engine is stopped.

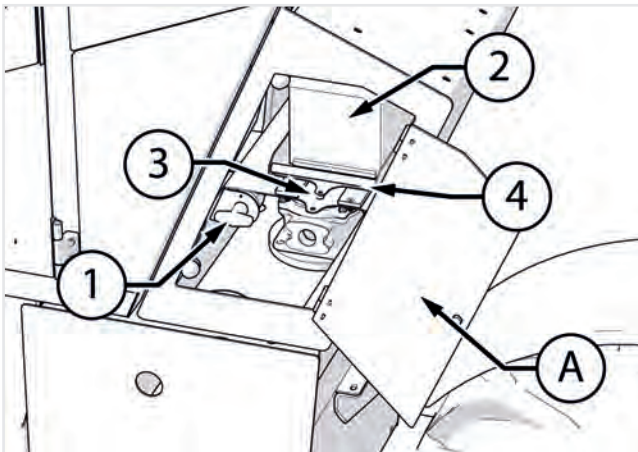

Figure: 150731-1

The battery cut-off switch "1" (150731-1) is located inside the compartment positioned behind the driver's cab, accessible opening the door "A". It allows the operator to isolate the battery from the electrical circuit in case of emergency or during maintenance operations.

To isolate the battery:

- Turn off the engine.
- Turn the ignition key to position "0".
- Turn the battery isolation switch counterclockwise to the off position.



#### NOTE

If the vehicle is provided with the basket pre-arrangement it is also provided with a battery isolation switch with removable key, to ensure that it is not used accidentally.

### 11.5.5 - Battery: Replacement

The vehicle is equipped with a battery "2" (fig. 150731-1) located inside the compartment positioned behind the driver's cab "A".

Before removing the battery disconnect it from the electrical circuit through the appropriate battery isolation switch, following the instructions given in the relevant chapter.

To remove the battery:

- Place the vehicle in the service position as described in the "Setting the vehicle for maintenance" section.
- To access the battery use the ignition key to open the compartment "A".
- Unscrew the pin "3".
- Remove the battery by pulling the slide "4".
- Disconnect the NEGATIVE cable (black) from the battery.

- Disconnect the POSITIVE cable (red) from the battery.
- Remove the battery from the vehicle.
- Place the new battery.
- Connect the POSITIVE (red) cable to the battery.
- Connect the NEGATIVE (black) cable to the battery.
- Place the slide "4" in its initial position and fix with the pin "3".
- Reactivate the battery isolation switch.
- Close the engine hood.

### 11.5.6 - Start up with auxiliary batteries



#### WARNING

**Start-up with auxiliary batteries is an operation that requires two properly trained and qualified operators.**

An error in executing the operations can cause serious damage to the vehicle, to property and people.

- When starting the engine using another vehicle, connect the accumulators in parallel. When connecting the cables, avoid contact between the positive cable "+" and the negative cable "-".
- Wear the necessary personal protective equipment before starting the operation.
- Take care to avoid contact between the vehicle to be started and the vehicle that must supply power to prevent sparks and explosions of hydrogen produced by the accumulators. The accumulator explosion causes serious damage and injury.
- Make sure not to exchange the ignition cables and first connect the earth cable (-) and then the positive cable (+).
- Be very careful when removing the ignition cables; to ensure that the cables disconnected from the accumulator do not touch other parts of the vehicle to avoid explosions caused by hydrogen.
- Cables and grippers must be proportional to the current load to be transferred. The accumulator to be used for the start-up must have a capacity greater than or at least equal to that of the standard accumulator installed.
- Check the cables and grippers for corrosion or damage. Make sure the grippers are tightly gripping the terminals.

- Be very careful during the different operations: direct or indirect contact with live parts can result in injury and sometimes even in death.
- When starting the engine, the operator must be in the driver's seat so as to keep the vehicle under control.
- All these operations must be carried out by skilled and trained personnel.

### 11.5.6.1 - Cable connection and engine start-up

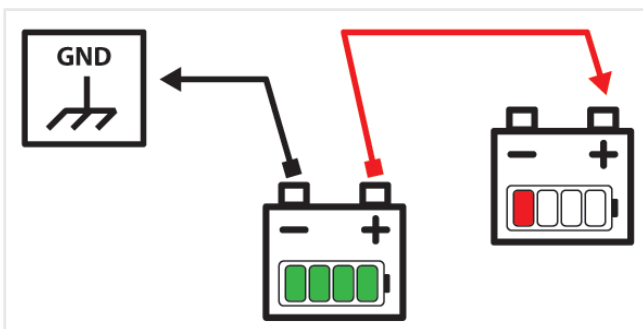

Figure: 150539-1

1. Make sure the ignition key is in position "O".
2. Connect the cable from the negative clamp "-" of the charged battery to the earth block of the vehicle to start-up.
3. Connect the positive terminals "+" of the two batteries to each other.
4. If a charged battery installed on a properly running vehicle is used, start the engine of the latter and run it at high rpm.
5. Start the engine of the failed vehicle.

### 11.5.6.2 - Cables removal

With the engine running remove the cables in reverse order of the connection.

1. Disconnect the positive cable "+" first from the battery used for starting and then from the low battery.
2. Disconnect the negative cable "-" from the earth of the running engine and therefore from the fully charged battery.

## 11.6 - Fuel



### DANGER



Never add different types of fuel such as petrol or alcohol to diesel.



It is forbidden to refuel while the engine is running.

It is forbidden to smoke when refueling.



### DANGER



Inhale diesel fumes for the least time possible as they are dangerous carcinogens for your health.

Before handling fuel and filling the tank, comply with the following regulations:

- Clean the area around the fuel cap. Refill the fuel tank at the end of every day to reduce condensation when the vehicle is at rest.
- Water and sediments must be removed before they reach the engine.
- Do not use antifreeze to remove water from diesel fuel.
- Do not rely on a filter to remove water from diesel fuel.
- Never leave the tank without a cap and always lock it. Should you lose the original cap, replace it with an original spare. Not just any cap is suitable.
- Keep the fuel pump gun under control while filling the tank.
- Do not inspect the tank with a flame.
- Do not fill up the tank completely. Leave room for expansion and immediately clean any spillage.
- In the event of fuel leaks due to breakage, stop the leak as quickly as possible, do not use the vehicle and contact DIECI customer service.

### 11.6.1 - Specifications for recommended fuel



### NOTE

To achieve good performance, see the engine manual of the vehicle to know the best features.

### 11.6.2 - Cleaning and storing fuel

It is important for the fuel to be kept clean.

The advice provided below will help maintain fuel quality.



- Never use zinc-coated containers.
- Never clean the inside of containers or power supply system components with cloths that may leave deposits.
- The cistern capacity must allow intervals between refueling not to be too long. A capacity of 3000 liters is sufficient for an average sized company.
- The storage cistern must be covered and placed on a support that is high enough to allow refueling by means of gravity. A large basin must be placed under the cistern in case of fuel leakage in order to collect it. The cistern must have an opening large enough to allow someone to access it for cleaning purposes.
- The delivery tap must be larger at the bottom in order to trap any deposits; it must also be equipped with a removable filter. The cistern should be tilted 40 mm per meter towards the sedimentation drain plug.
- The fuel barrels must be covered when stored to prevent water infiltration. The barrels should be slightly tilted slightly, so that any water will run to the upper rim. The fuel barrels should not be stored for too long before being used.
- If the barrels are kept outside, their caps must be tightly closed to prevent water from seeping in.
- After refueling the storage cisterns or barrels, it is recommended to allow the fuel to set for at least two hours, thereby allowing any sediment of water and impurities to be deposited before the fuel is used.

**11.6.3 - Refueling**

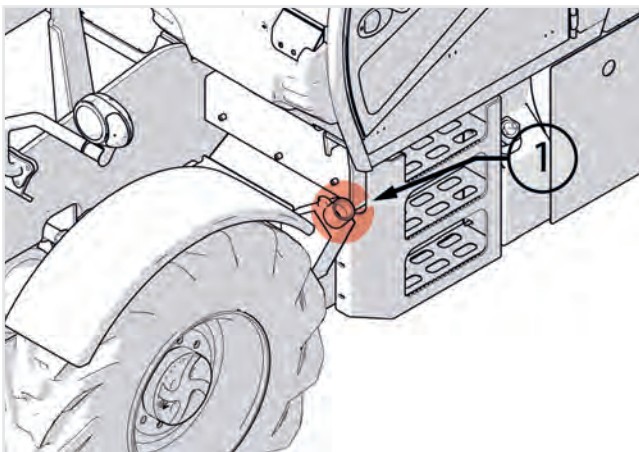

Figure: 150724-1

When refueling (fig. 150724-1) it is necessary to:

- Park the vehicle and turn off the engine
- Open the fuel cap
- Refuel
- Close the fuel cap

**11.6.4 - Fuel tank: Cleaning**

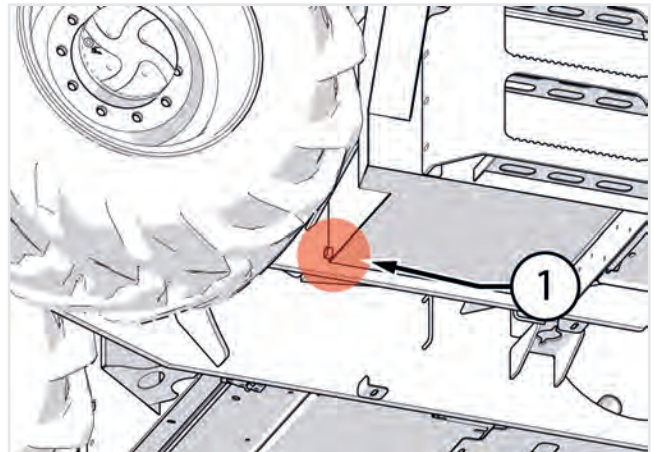

Figure: 150725-1

With the vehicle in the maintenance position:

- Place a suitable container under the fuel tank.
- Remove the plug from under the tank (fig. 150725-1) and drain the fuel to remove impurities present in the tank.
- Put back the cap and fill with clean fuel.

**11.7 - Safety stickers: Inspection**

- Check that all safety stickers are intact and in good condition.



**NOTE**

Refer to the chapter "Safety Stickers Cleaning" for cleaning the safety stickers.

**11.8 - Lubrication**

Lubricate the points shown in the figure until grease comes out and clean the lubricators from dirt or deposits.

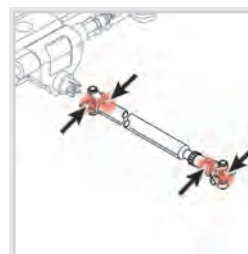

Drive shafts lubrication points.

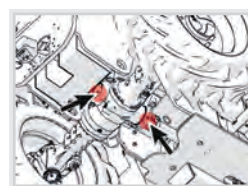

Swinging axle lubrication points.

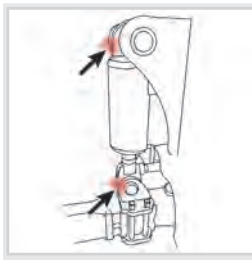

Levelling cylinder lubrication points.



Lifting cylinder lubrication points.

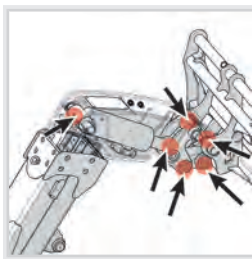

Counter lever and swing cylinder lubrication points.

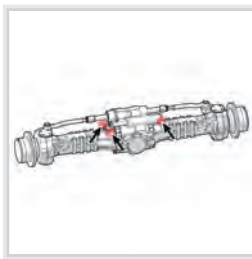

External parking brake cylinder lubrication points.

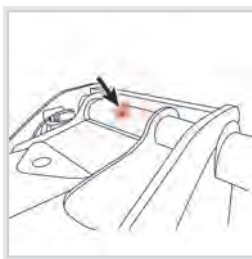

Boom-chassis pin lubrication points.

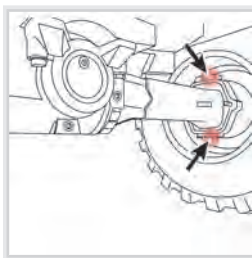

Wheels lubrication points.

## 11.9 - Engine maintenance



### NOTE

For the engine maintenance operations, refer to it manual.

### 11.9.1 - Belts: Check and adjustment

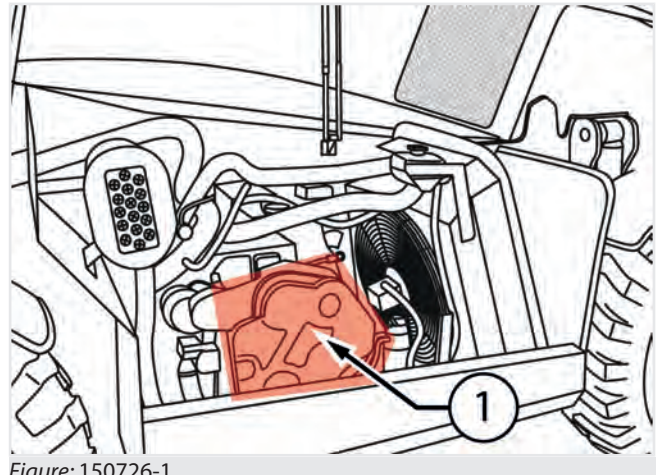

Figure: 150726-1

Check that the belt "1" (fig. 150726-1) does not have cuts, cracks or rubbing signs; when in doubt, install a new belt.

Make sure that the belt is properly fit on the pulleys and that the tensioner is working properly.

**NOTE!** If the belt does not appear in good condition, replace it with a new one.

### 11.9.2 - Engine oil: Check and filling up

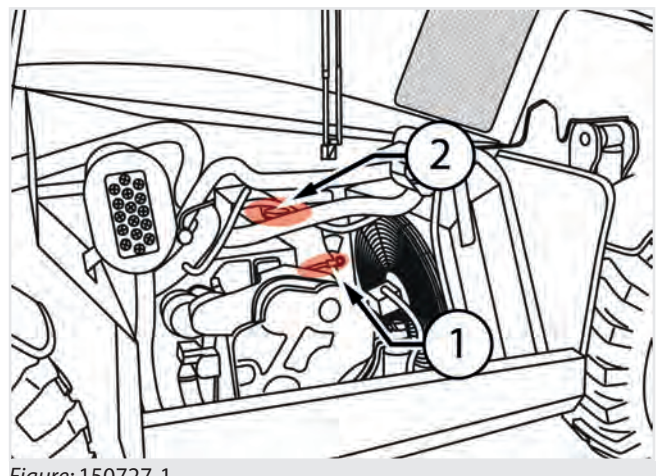

Figure: 150727-1

- Check the level with the vehicle on level ground and the engine turned off. Wait at least 5 minutes to allow the oil to settle into the sump.



- Pull out the dipstick "1" (fig. 150727-1), clean it and insert it back fully down.
- Pull out again the dipstick "1" and check that the oil level is between the "MIN" and "MAX" mark.
- Put back the dipstick and insert it fully down.
- If necessary, add oil from the cap on the engine "2".

For the amount and type of oil, refer to the engine manual.



**WARNING**

**Do not fill beyond the "MAX" mark; if the amount is excessive, oil burns with production of smoke and gives the false impression of oil consumption.**

Never operate the engine with the oil level below the "MIN" mark.

**11.10 - Air filter: Cartridges cleaning and replacement**



**ATTENTION**

The inspection, cleaning and replacement must be carried out with the vehicle in the maintenance position.

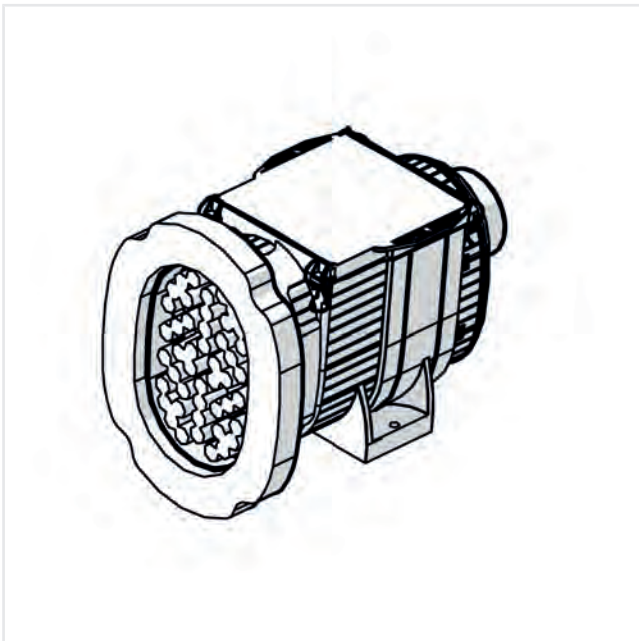

Figure: 150615-1

An air filter (fig. 150615-1) in bad conditions results in the reduction of power, excessive fuel consumption and reduced engine life.



150615-2

A clogged filter is signaled by the indicator light (fig.150615-2) located on the dashboard of the vehicle; after the clogging indication it is possible to continue operating for a period not longer than 10 hours. The maintenance must however be performed at the frequency required.



**WARNING**

When the clogging is indicated, it is possible to continue working for not more than one hour.

It is recommended to:

- Clean the filters only when the indicator light indicates clogging or at the frequency required. Unnecessary and too frequent cleaning exposes the elements to damage by handling that can allow dust and dirt to pass through the filtering stage and cause engine damage.
- In case the filter elements are in contact with liquids of any kind they must be replaced.
- Periodically check the intake sleeves, replace them immediately in case they are damaged or deteriorated.
- Periodically check the tightness of the bolts and clamps. Air must not be allowed to get into the engine circulation without having first gone through the filter.

For the complete efficiency of the filter it is recommended to operate with the filter complete with all its parts and components, assembled in the correct way.

Each deteriorated part must be replaced as soon as possible.



**ATTENTION**

**For the complete efficiency of the filter it is recommended to operate with the filter complete with all its parts and components.**

Each deteriorated part must be replaced as soon as possible.

It is absolutely forbidden to operate without the engine air filter.

The engine sucks air constantly during its use; dust particles entering in circulation may cause serious damage.

For proper cleaning of the filter it is necessary to:

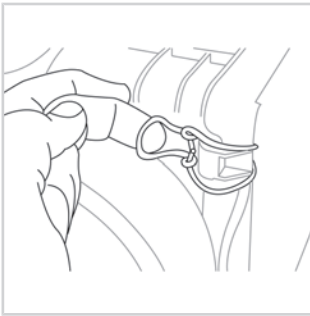

150615-3

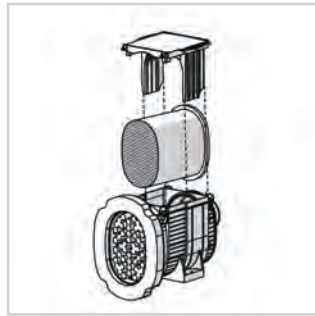

150615-4

- Prepare the vehicle in the maintenance position.
- Open and lock the hood.
- Open the filter cover (fig. 150615-3) pulling the locking levers located on the four corners.
- Lift the cover and remove the cartridge from inside the filter (fig. 150615-4).
- Use a wet lint-free cloth to clean the box and the cover.
- Clean or replace the filters. The filter cleaning is carried out with compressed air, up to **3 bar** (43.5 psi), at a distance of not less than **150 mm** (5.9 in), taking care not to damage the filtering element.
- Reassemble everything carrying out the same operations in reverse.

For a correct cleaning of the suction ducts it is necessary to:

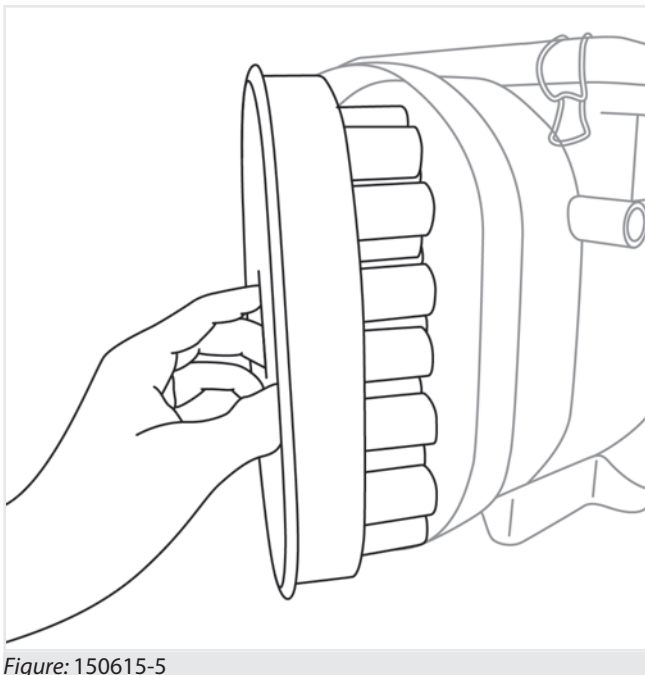

Figure: 150615-5

- Prepare the vehicle in the maintenance position.
- Open and lock the hood.

- Loosen the screw that secures the inlet honeycomb.
- Remove the air inlet honeycomb (fig. 150615-5).
- Use a wet lint-free cloth for cleaning. Clean every air inlet hole.
- Put back the inlet honeycomb in its seat.



## NOTE

In case the connection gasket between the suction duct and the filter is damaged, it must be replaced.

## 11.11 - Radiator maintenance

### 11.11.1 - Air recirculation grids and nets

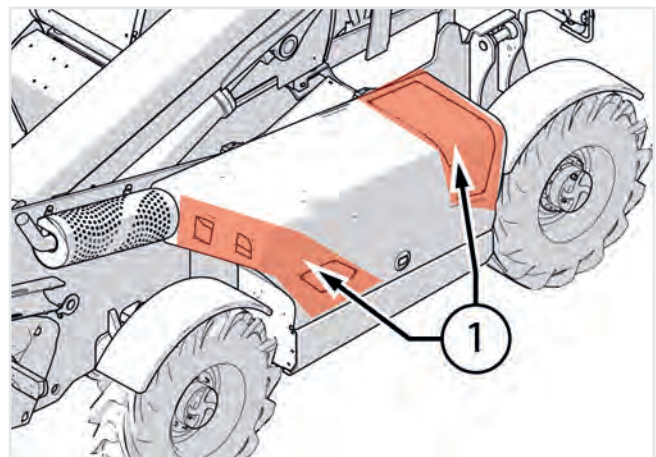

Figure: 150728-1

Check that the air recirculation networks and grids "1" (fig. 150728-1) are clean and free from dirt:

For cleaning use a jet of air at low pressure from the inside to the outside of the vehicle.

### 11.11.2 - Radiator: Checking and cleaning

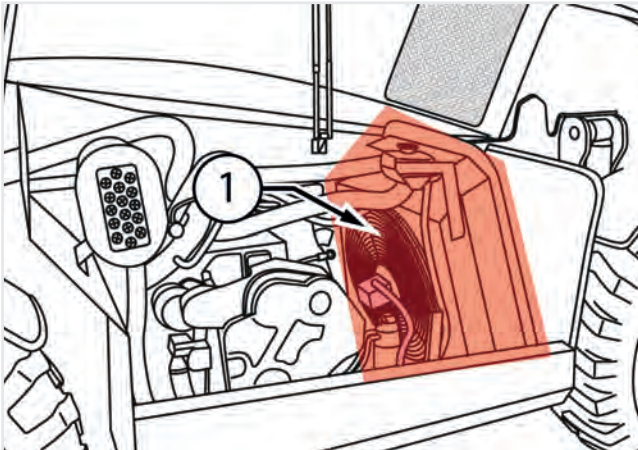

Figure: 1507291-

The oil and water radiator "1" (fig. 150729-1) involve the following steps:

#### Radiators check

Check that the fins are not deformed; in that case straighten with caution.

Check that the fins have not accumulated dirt and that they are not obstructed.

#### Radiators cleaning

Prepare the vehicle in the maintenance position.

Clean the radiator from dirt and impurities accumulated between the cooling fins. For cleaning use compressed air with pressure not exceeding 7 bar directed from the inside towards the outside.

If necessary, apply a detergent solution and then remove it with a pressure washer.

### 11.11.3 - Radiator: Liquid filling up and replacement



#### DANGER

**Do not remove the filling cap of the radiator when the system is hot, otherwise it could cause leakage of boiling coolant. Once the system has cooled, turn the filling cap to the first mark and wait until the pressure has completely exhausted before proceeding.**

Risk of burns and injuries.



#### DANGER

**The coolant can be toxic. Avoid contact with skin, eyes or clothing. Rinse thoroughly with water in case of contact with skin and eyes. Consult a doctor immediately.**

If not reused, dispose of in accordance with local environmental regulations.

#### Filling up

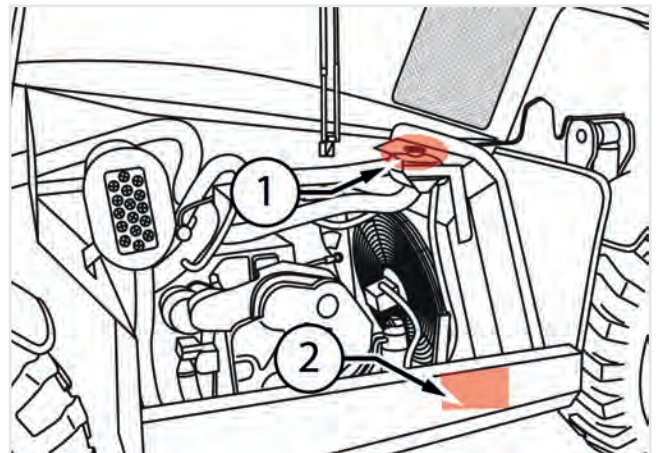

Figure: 150730-1

- Prepare the vehicle in the maintenance position.
- Open the engine hood.
- Slowly unscrew the filler cap "1" (fig. 150730-1) counterclockwise until it reaches the safety latch.
- Exhaust the residual pressure and steam.
- Add the coolant up to the level of **30 mm (1.2 in)** below the cap.
- Put back the cap.
- Close the engine hood.

#### Coolant replacement

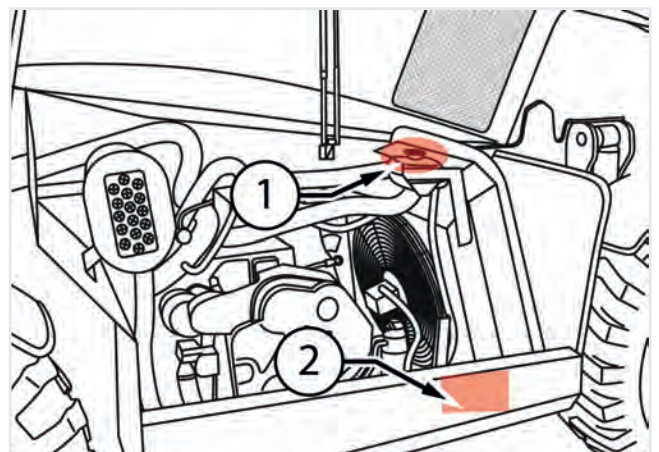

Figure: 150730-2



- Prepare the vehicle in the maintenance position.
- Open the engine hood.
- Remove the discharge sleeve "2" (fig. 150730-2) to drain water from the radiator.
- Remove the filling cap "1" to speed draining.
- Allow the cooling system to completely drain.
- Rinse the radiator with clean demineralized water introducing it from the filling cap "1" and making it flow out from the orifice of the sleeve "2". If necessary, add detergent.
- Check the condition of sleeves and their fittings, replace them if necessary.
- Once cleaning has been completed, refit the drain sleeve "2".
- Fill the cooling system from the filler cap "1" until the level is **30 mm (1.2 in)** below the cap with the coolant previously prepared.
- Close the filler cap.
- Close the engine hood.
- Start the engine at idle speed for a few minutes.
- Make sure there are no leaks, check the level and add more liquid if necessary.

## 11.12 - Hydraulic system maintenance

### 11.12.1 - Hydraulic oil: Check and replacement

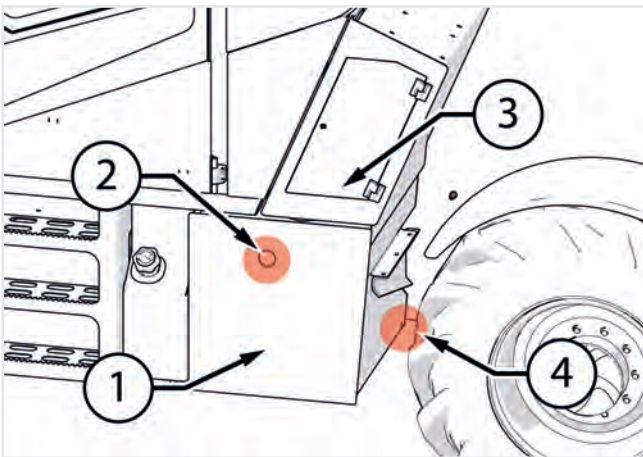

Figure: 150946-1

The hydraulic oil tank is located on the left side of the vehicle under the cab "1" (fig. 150946-1).

The level can be checked through the transparent cap placed on the left side of the vehicle "2".

The level is correct when the oil is visible from the transparent cap "2" with all the cylinders of the vehicle in the transport position.



### NOTE

See the chapter "Technical data" to know the amount and type of recommended oil.

#### Oil check

To keep the vehicle in normal operation conditions, it is necessary to keep the oil level in best conditions.

To properly check the oil level in the tank it is necessary (fig. 150946-2):

- Prepare the vehicle in the maintenance position.
- Make sure that all cylinders and jacks of the vehicle are retracted (e.g. telescopic boom fully retracted and lowered, attachment holding plate tilted down as much as possible to avoid contact with chassis or tires). In this way all the oil of the hydraulic circuit will be sent in the tank.
- Check the oil level through the transparent cap "2". Under the best conditions, the oil level reaches the middle of the transparent indicator.
- If necessary, remove the cap of the tank "3" located inside the compartment behind the cab, and add oil until it reaches the proper level.
- Put back the filler cap "3".

#### Oil change

To change oil in the tank (fig. 150946-3) it is necessary to:

- Prepare the vehicle in the maintenance position.
- Make sure that all cylinders and jacks of the vehicle are retracted (e.g. telescopic boom fully retracted and lowered, attachment holding plate tilted down as much as possible to avoid contact with chassis or tires). In this way all the oil of the hydraulic circuit will be sent in the tank.
- Place a container under the drain plug (located under the tank) "4".
- Remove the filler cap "3".
- Remove the drain plug to let the oil drain "4".
- After draining the oil, put back the drain plug "4".
- Fill the tank with the oil indicated
- Check the level through the indicator "2" after starting the engine and operated all hydraulic controls to remove air bubbles, if any.
- Close the filling cap "3".
- If necessary, top up the level

**11.12.2 - Hydraulic oil intake filter:  
Replacement**

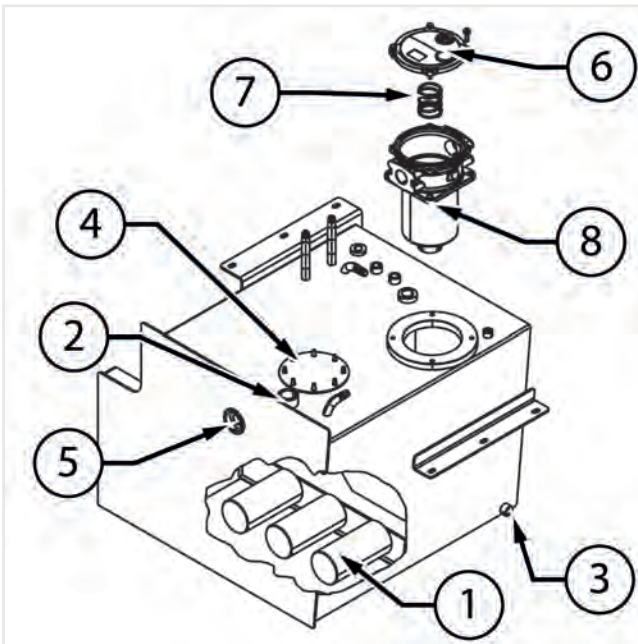

Figure: 150946-1

The internal hydraulic oil intake filters "1" (fig. 150946-5) are located inside the hydraulic oil tank; to replace them, completely empty the tank. It is therefore advisable to carry out the replacement of the intake filters in conjunction with the oil change.

To replace the intake filter, carry out the following operations (fig. 150946-5):

- Prepare the vehicle in the maintenance position.
- Make sure that all cylinders and jacks of the vehicle are retracted (e.g. telescopic boom fully retracted and lowered, attachment holding plate tilted down as much as possible to avoid contact with chassis or tires). In this way all the oil of the hydraulic circuit will be sent in the tank.
- Place a container under the drain plug (located under the tank).
- Remove the filler cap "2".
- Remove the drain plug to let the oil drain "3".
- After completely draining the oil, remove the flange "4" to access to the intake filters.
- Unscrew the intake filters "1" located inside the tank with an adjustable spanner.
- Install new filters and tighten with a wrench.
- Put back the drain plug "3".
- Fill the tank with the oil indicated.
- Check the level through the indicator "5" after starting the engine and operated all hydraulic controls to remove air bubbles, if any.
- If necessary, top up the level.

**11.12.3 - Hydraulic oil return filter:**

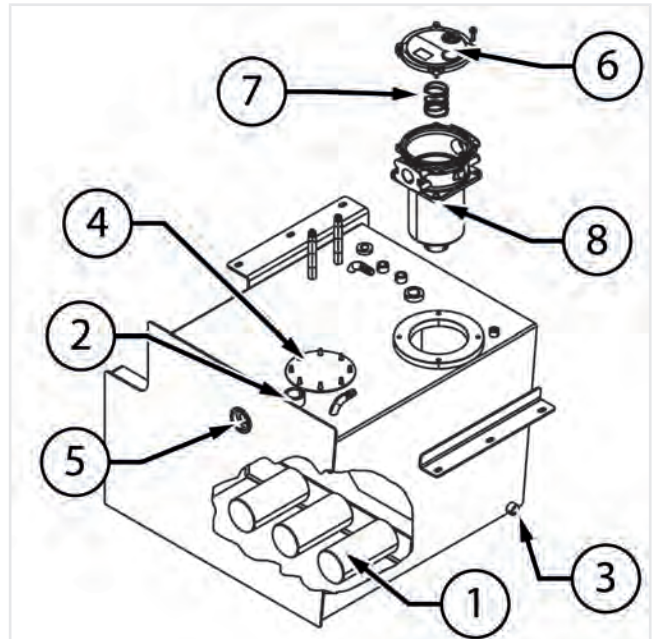

Figure: 150946-8

To replace the hydraulic oil return filter (fig. 150946-8) carry out the following operations:

- Prepare the vehicle in the maintenance position.
- Access the compartment located behind the vehicle driver.
- Remove the cover "6" unscrewing the 4 screws. Be very careful as the internal spring "7" pushes the cover outward.
- Remove the inner cartridge of the filter "8" and replace it with a new one.
- Remove the spring "7" from the empty cartridge and insert it into the new one.
- Insert the new cartridge in its housing, the spring must be located in the top of the cartridge.
- Close the cover being careful to correctly position the spring. Tighten and check that there are no leaks.

### 11.12.4 - Hydraulic oil filter

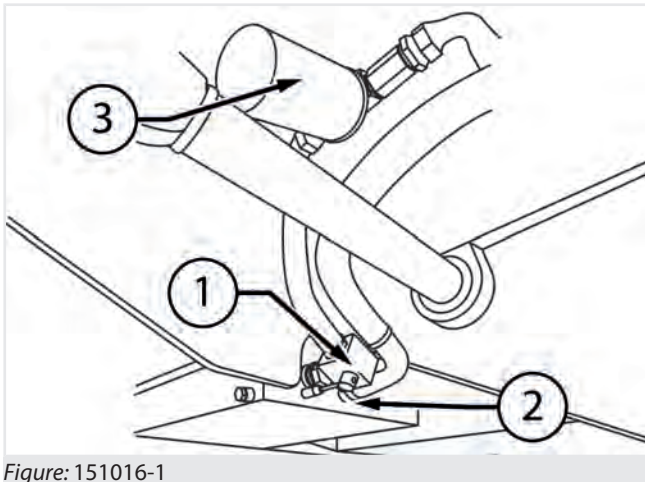

Figure: 151016-1

To replace the hydraulic oil return filter (fig. 151016-1) carry out the following operations:

- Prepare the vehicle in the maintenance position.
- Place a container under the filters in order to collect the oil coming out during replacement.
- Remove the lock screw "1".
- Close the valve "2" to avoid emptying the tank.
- Unscrew the filter cartridge "3" one at a time with a strap wrench.
- Clean the filter supports with a clean lint-free cloth. Check that the old sealing rings are removed.
- Take the new filters and fill them with hydraulic oil of the approved type. Use the same oil to lubricate the new sealing gaskets.
- Screw the filters only with the help of hands paying attention to the correct positioning of the previously lubricated sealing gaskets.
- Return the valve "2" in its original position.
- Secure the valve with the screw "1" previously removed.
- Start the vehicle and check for leaks.

## 11.13 - 2 speed transmission maintenance

### 11.13.1 - Oil change: Inspection

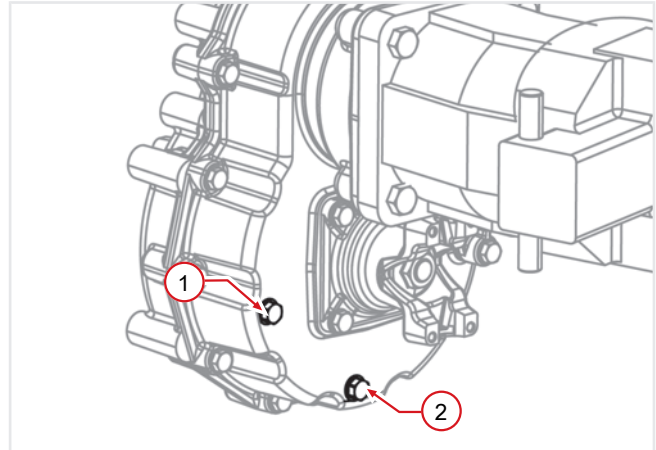

Figure: 150619-1

- Set the vehicle in the maintenance position.
- Place a container under the gearbox.
- Take the level cap off "1" (fig. 150619-1), oil must leak out from the hole.
- If necessary, top-up through the hole of the cap until the oil seeps through

### 11.13.2 - Oil change: Check and replacement

- Set the vehicle in the maintenance position.
- Place a container under the gearbox.
- Remove the level cap "1" (fig. 150619-1) and the drain plug "2".
- Allow the oil to completely drain out.
- Refit the drain plug and tighten it securely.
- Top-up with approved type of oil from cap "1" until the oil seeps through.



## 11.14 - Brakes maintenance

### 11.14.1 - Brake: Inspection

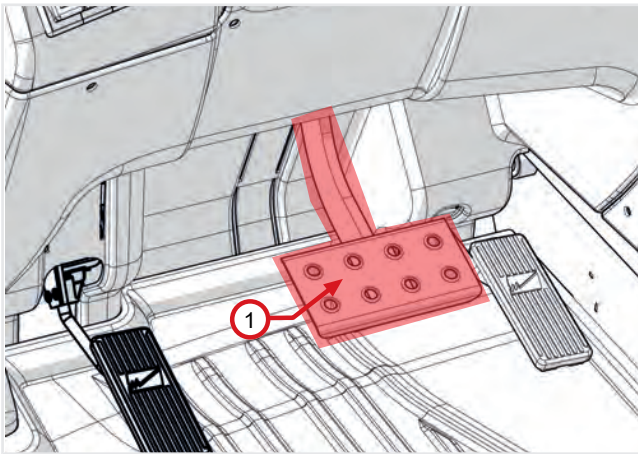

Figure: 161050-1

Visually check that the joints of the pedals (fig. 161050-1) are not damaged and that the pedal stroke is not excessive or too elastic.



#### DANGER

**If irregularities in braking are noticed, contact qualified personnel to verify the cause of the trouble.**

The braking parts also safeguard the operator's safety, do not intervene personally on the braking system trying to eliminate possible anomalies.

### 11.14.2 - Brake: Coolant level check

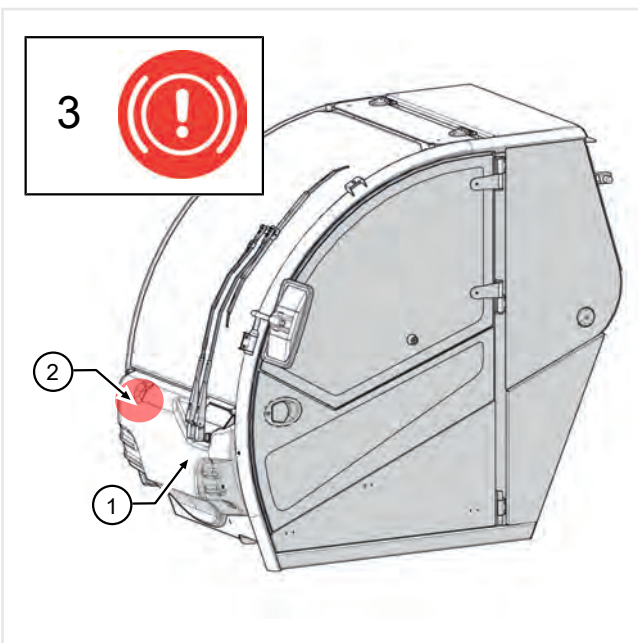

Figure: 150709-1

When the indicator light "3" (Brake fluid level low) flashes on the central instrument, it means that the brake fluid level has dropped below the minimum (MIN) and therefore it must be restored.

To access the tank, remove the front protection housing of the cab "1" (fig. 150709-1) and check that the oil level is always above the minimum level (MIN) indicated on the tank "2". If necessary top up from the cap.

**WARNING! If the light "3" stays on even after adding oil, contact a Dieci authorized service center to solve the problem.**

A slight lowering of the level is due to normal wear of the brake discs.

Do not press the brake pedal until the topping up is completed. Make sure the tank is closed before acting on the pedal.



#### DANGER

**The significant lowering of the level is an indication of leakage in the system. Refer to qualified personnel for the replacement of any damaged, corroded or ruined pipe.**

It is absolutely forbidden to operate with brake oil level below the minimum "MIN". The brakes may operate erratically with the risk of accidents.



#### ATTENTION

Always use oil of the prescribed grade, as indicated in "Technical data" chapter.

This type of oil can damage painted surfaces and plastic parts of the instrument panel. For safety precautions, refer to the "Safety regulations" chapter.

## 11.15 - Wheel maintenance

### 11.15.1 - Epicycloidal reduction gear oil: Check and replacement

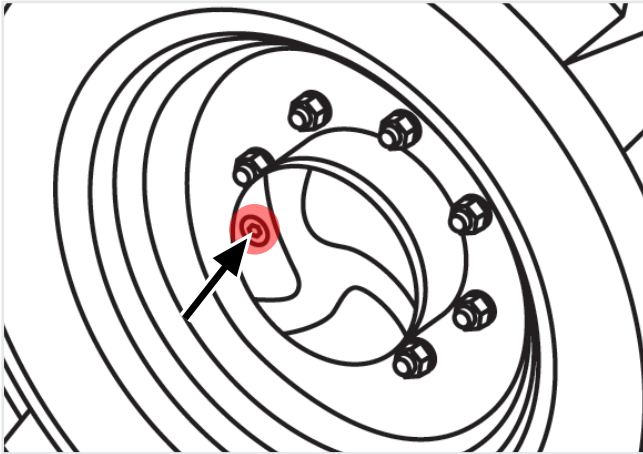

Figure: 150577-1

The oil cap of the epicycloidal reduction gear is located on the wheel hub (fig. 150577-1):

#### When checking the oil level it is necessary to:

- Prepare the vehicle in the maintenance position.
- Turn the wheel for the oil cap to be in the horizontal position (9 o'clock).
- Place a container to collect the oil.
- Remove the cap and verify that the oil seeps from the hole.
- If necessary, top-up through the same hole.
- Close the cap and tighten it securely.

#### When replacing the oil it is necessary to:

- Prepare the vehicle in the maintenance position.
- Turn the wheel for the oil cap to be in the lowest possible position (6 o'clock).
- Place a container to collect the oil.
- Remove the cap and let the oil drain completely.
- Turn the wheel and bring the cap to the horizontal position (9 o'clock).
- Fill through the same cap with new oil until it seeps through.
- Close the cap and tighten it securely.

### 11.15.2 - Wheel nuts tightening



#### NOTE

Tighten the nuts at the intervals required in the maintenance table.

Use the corresponding table to know the correct tightening torque.

Always tighten the nuts in opposing position, not consecutively.

After installing the wheel, tighten the nuts between the wheel and the axles. Then check the nut torque every day until the torque is stabilized.

The number of axle columns must match the number of nuts tightened. Then all the nuts on each wheel must be installed otherwise the vehicle can not operate.

In case of wheel replacement the vehicle or the raised side can be placed on the ground only with wheels installed and properly tightened.

The nuts tightening must be made first with the vehicle, or part of it, raised from the ground then with vehicle resting on the ground.

Only use **DIECI** original nuts for tightening the wheels. If you lose even one nut contact the **DIECI** service center.

### 11.15.2.1 - Wheel nuts tightening: Inspection

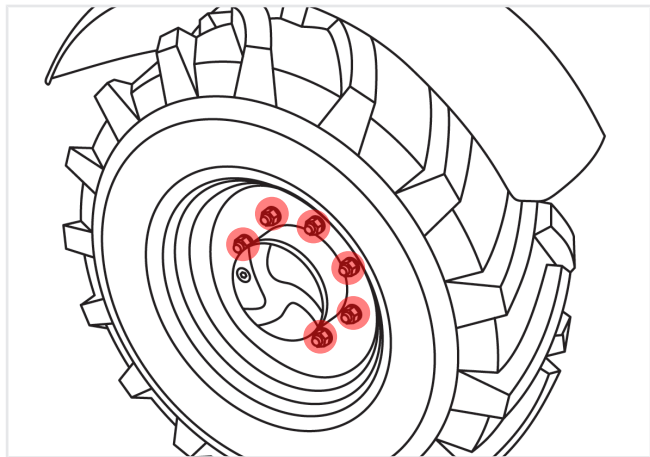

Figure: 150578-1

Check that the nuts of the front and rear wheels are tightened well, using a torque wrench (with a torque multiplier, if necessary).

Tapered nut	Torque
M18x1.5	460 N·m (339,02 ft·lbs)
M22x1.5	740 N·m (545,38 ft·lbs)

11.15.3 - Tyres



**ATTENTION**

The diagrams notebook in the cab and the "Technical data" chapter show the tyres available for your vehicle model and the relative inflation pressures.



**ATTENTION**

On receiving the vehicle check the air pressure of the tyres.

- Check the tyre pressure regularly. The pressure must be checked with cold tyres.
- The tyre pressure must always be at the levels indicated.
- Check the size of the tyres installed and the number of canvasses for the correct inflation pressure.



**DANGER**

Tyres showing cuts or excessive wear must be replaced immediately.

- At each use, check that the tyre shoulders are not damaged.
- Keep oil, grease and corrosive liquids away from the tyres to avoid deterioration of the rubber.
- To obtain the maximum efficiency do not use tyres with more than 80% of tread wear.



**WARNING**

**Inflating or operating on the tyres can be dangerous.**

To operate on tyres or install them, contact specialised personnel.

In any case, to prevent serious or fatal injuries, follow the safety precautions below.

- The vehicle wheels are very heavy. Handle with care and make sure that, once stored, they can not fall and injure someone.
- Never try to repair a tyre on a public road or highway.
- Make sure the jack is placed on a solid and flat surface.
- Make sure the jack is adequate for lifting the vehicle.
- Use ratchet jacks or other locking means suitable to support the vehicle during the tyres repair.

- Do not place any part of the body under the vehicle.
- Do not start the engine while the vehicle is on the jack.
- Never hit a tyre or a rim with a hammer.
- Make sure the rim is clean, without rust and undamaged. Do not weld, solder, repair in any way or use a damaged rim.
- Do not inflate a tyre unless the rim is mounted on the vehicle or secured in such a way that it cannot move in case the tyre or rim should break suddenly.
- Do not inflate any tyre over the pressure indicated by **DIECI**. If the bead chafer does not settle on the rim, when arriving to this pressure deflate the tyre and lubricate again with a solution of soap and water, inflate again. Do not use oil or grease. An inflation greater than permitted with bead chafer not settled may break the bead or rim with explosive force sufficient to cause serious injury.
- After installing the wheel, tighten the nuts between the wheel and the axles. Then check the nut torque every day until the torque is stabilized.



**ATTENTION**

**When fitting a new or repaired tyre, use a valve adapter of spring type with distant pressure gauge that allows the operator to stay well away from the tyre during inflation.**

Use a safety cage.

11.15.3.1 - Tyre pressure: Inspection

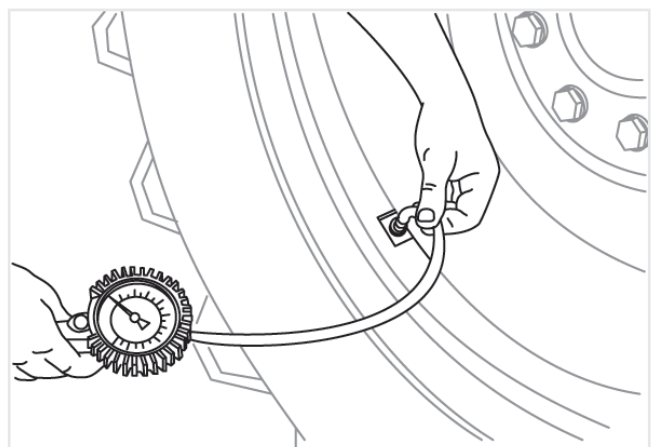

Figure: 150578-1

Verify and adjust the pressure of the front and rear tyres.  
Check that the tread and the sides are not damaged.

Connect a pressure gauge to the tyre valve and verify that the inflation pressure is correct.

11.15.3.2 - Tires filled with urethane



**NOTE**

**Tires filling with urethane is an optional accessory.**

Consult your dealer in case of doubts or information on your vehicle.



**DANGER**

**It is not permitted to fit tires inflated with polyurethane foam unless authorized by the manufacturer.**

With tires filled with urethane it is forbidden to travel on the road.



**ATTENTION**

The maximum permitted speed with tires filled with urethane is 20 km/h (12.4 mph).

11.15.3.3 - Pneumatic symbols key

Icon	Description
	<b>Tyre dimensions</b> Indicates the tyre pressure.
	<b>Tread pattern</b> Indicates the design with which the tyre tread is carved.
	<b>Load index and Speed index</b> The load index corresponds to the maximum load that the tyre can support. The speed index indicates the maximum speed at which the tyre can bear the weight corresponding to its load index.
	<b>Tyre pressure</b> For most vehicle models, tyre pressure is the same for all wheels.
	<b>Front axle tyre pressure</b> For some vehicle models, the tyres must be inflated with different pressures between the front axle and the rear axle.
	<b>Rear axle tyre pressure</b> For some vehicle models, the tyres must be inflated with different pressures between the front axle and the rear axle.

11.16 - Lighting

The vehicle lighting must always be efficient and fully functional. Its operation must be checked every day. In case of damage to the lighting system immediately replace the damaged part. Immediately replace a burned out bulb.



**ATTENTION**

Refer to the "Maintenance" chapter before making any adjustments or maintenance.



**NOTE**

The bulbs are very fragile. Handle with care.

The low beam bulbs must not be handled with bare hands.

11.16.1 - Headlight

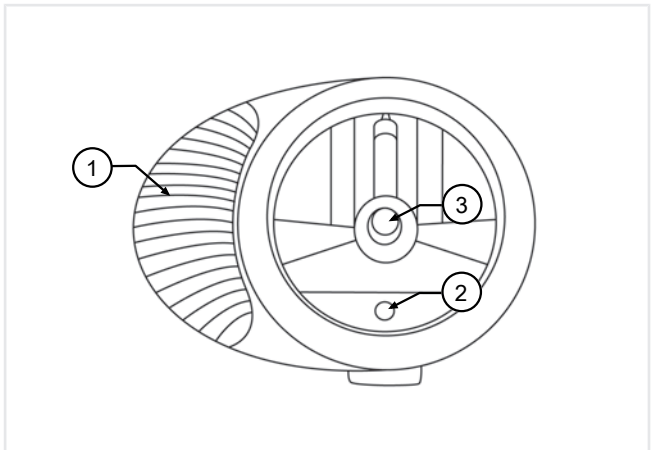

Figure: 150301-1

- 1 Direction indicator - 21 W
- 2 Front side light- 4 W
- 3 Low beam and high beam light - 60/55 W H4

To access the bulbs:

- Prepare the vehicle in the maintenance position.
- Turn off the battery isolation switch to disconnect power to the electrical system.
- Remove the power supply connector on the back of the light.
- Remove the front of the headlight by loosening the screws placed in the rear cap.

To close the headlight operate in the reverse order, paying attention to correct positioning of the sealing gasket.

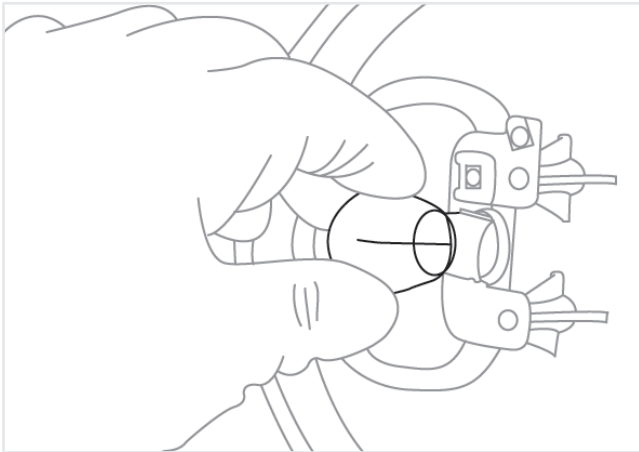

Figure: 150302-1

**Direction indicator bulb replacement**

- Press the top of the bulb (fig. 150302-1).
- Turn the bulb, keeping it pressed, to release it from the lock.
- Perform the same procedure to insert the new bulb.

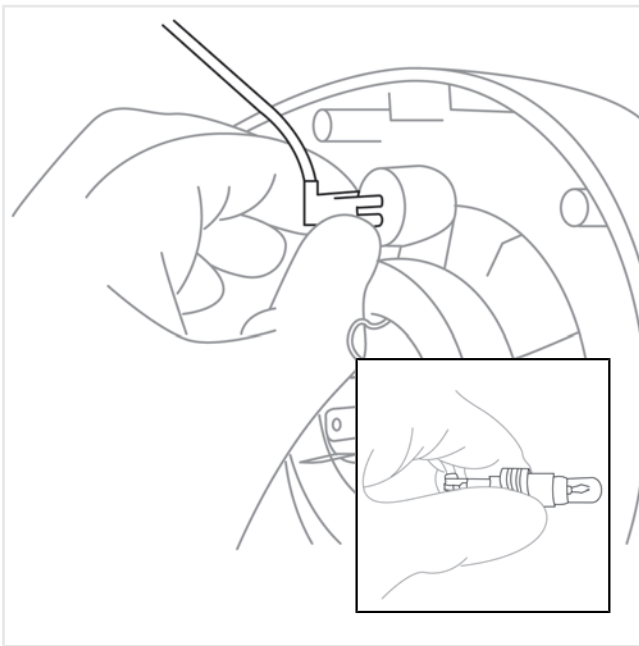

Figure: 150302-2

**Sidelight bulb replacement**

- Grasp the rear part where the electrical connections are placed (fig. 150302-2).
- Turn and pull the rear part towards you.
- Extract the support, press the top of the bulb.
- Turn the bulb, keeping it pressed, to release it from the lock.
- Perform the same procedure to insert the new bulb. Put back the support inside its seat.

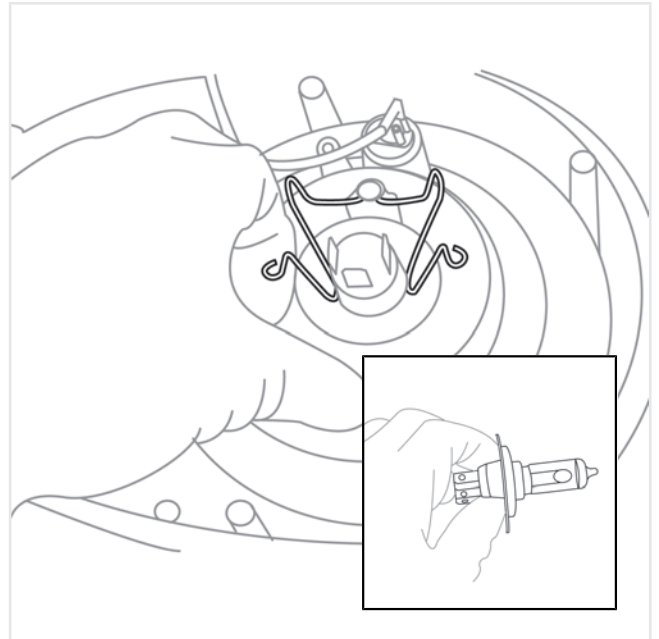

Figure: 150302-3

**Low/high beam light bulb replacement**

- Remove the electrical connector pulling it towards you.
- Lift the locking tabs (fig. 150302-3) moving them sideways to release the bulb.
- After replacing the bulb, proceed in the reverse order to lock and connect it again. Observe the joints of the lamp for proper insertion.

**11.16.2 - Tail light**

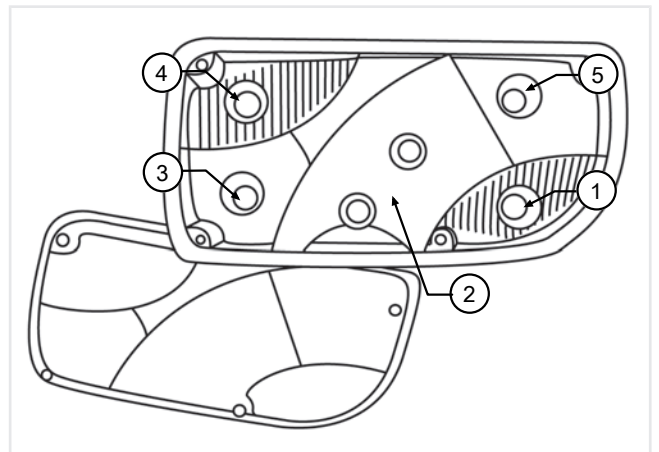

Figure: 120304-1

- 1 Reversing light - 21 W
- 2 Rear side light- 5 W
- 3 Braking light - 21 W
- 4 Direction indicator - 21 W
- 5 Rear fog light - 21 W

To access the bulbs:



1. Prepare the vehicle in the maintenance position.
2. Turn off the battery isolation switch to disconnect power to the electrical system.
3. Remove the power supply connector on the back of the light.
4. Remove the front of the headlight by loosening the screws placed in the cap.

To close the headlight operate in the reverse order, paying attention to correct positioning of the sealing gasket.

- Turn the socket, keeping it pressed, to release it from the lock.

Perform the same procedure in reverse order to insert the new bulb.

### Tail light bulb replacement.

- Press the top of the bulb.
- Turn the bulb, keeping it pressed, to release it from the lock.
- Perform the same procedure in reverse order to insert the new bulb.

### 11.16.3 - Work light \*



#### NOTE

\* The work light is an optional accessory.

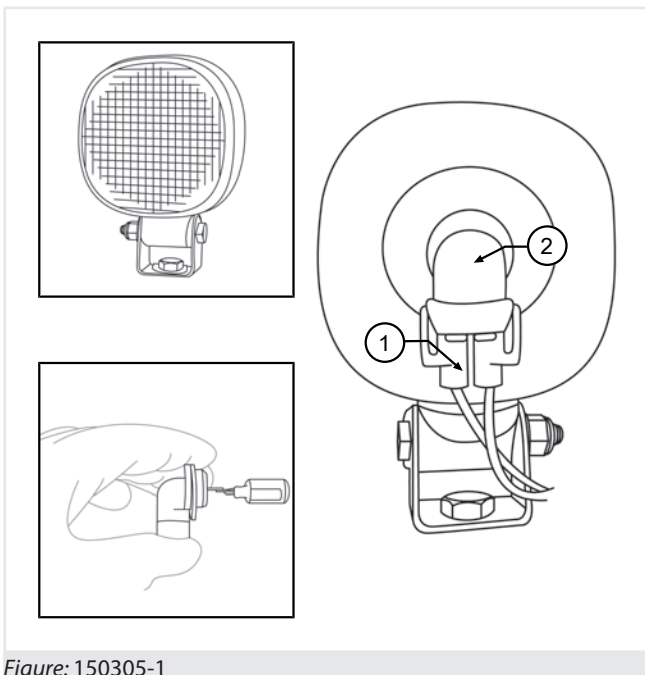

Figure: 150305-1

#### Work light bulb replacement

To access the bulbs (fig. 150305-1):

- Prepare the vehicle in the maintenance position.
- Turn off the battery isolation system to disconnect power to the electrical system.
- Remove the power connector at the back of the light "1".
- Press the connector socket on the light "2".

### 11.16.4 - Led work light\*



#### NOTE

\* The LED work light is an optional accessory.

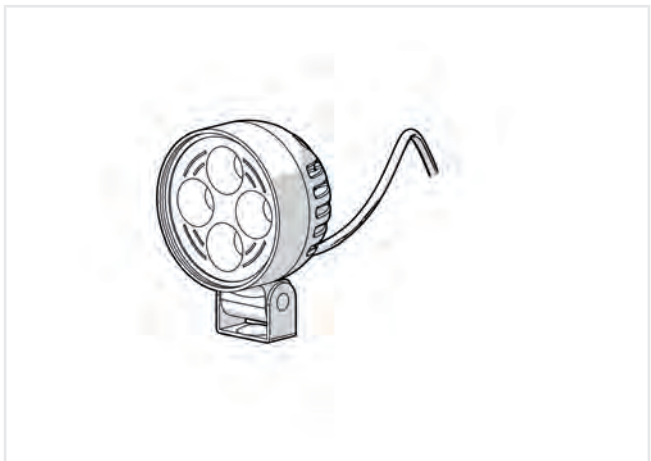

Figure: 150303-1

The LED work light (fig. 150303-1) does not require maintenance.



## 11.17 - Window washer fluid tank

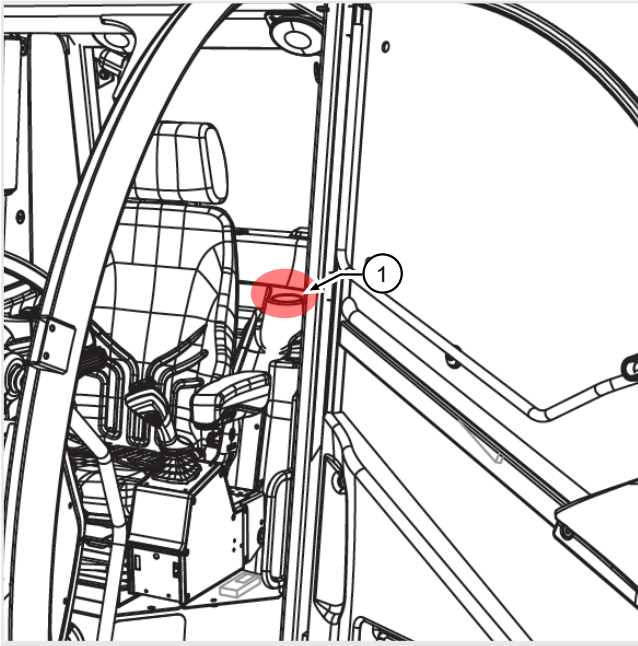

Figure: 150466-1

The washer fluid tank is located in the cab on the left side of the seat "1" (fig. 150466-1).

To add liquid to the tank:

- Remove the filling cap.
- Add washing fluid to fill the tank.
- Put back the cap.



### ATTENTION

During the winter, mix antifreeze fluid to the water.

## 11.18 - Ventilation system maintenance

### 11.18.1 - Cab ventilation filter: Cleaning and replacement

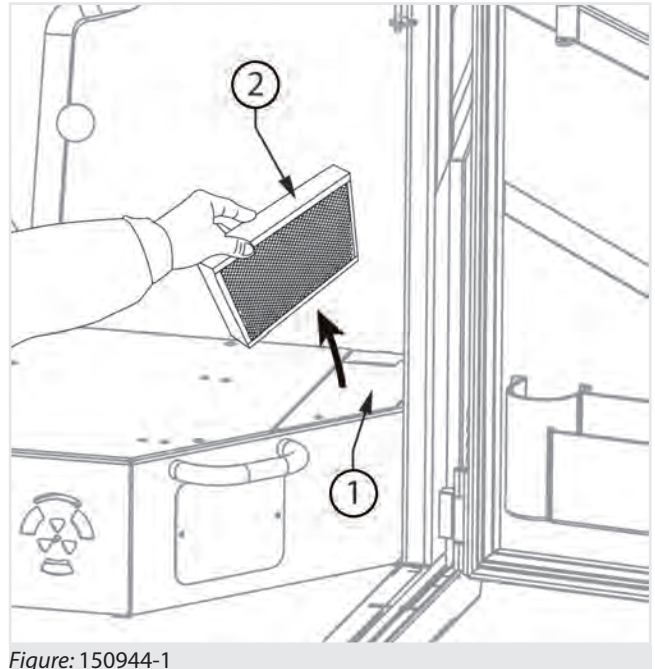

Figure: 150944-1

When changing the cab ventilation filter, clean the suction duct with a jet of air from inside the cab to the outside.

- Prepare the vehicle in the maintenance position.
- Remove the housing "1" (fig. 150944-1), located on the left part of the seat, unscrewing the fixing screw.
- Remove the filter "2".
- Replace or clean the filter cartridge by tapping gently on a flat surface, with the outer side facing down, being careful not to damage it; or use a jet of air (less than 6.9 bar) by blowing from the inside to the outside.
- Refit the filter "2".
- Put the housing back in place "1".
- Restart the engine with the fan in motion to verify the correctness of the operations.

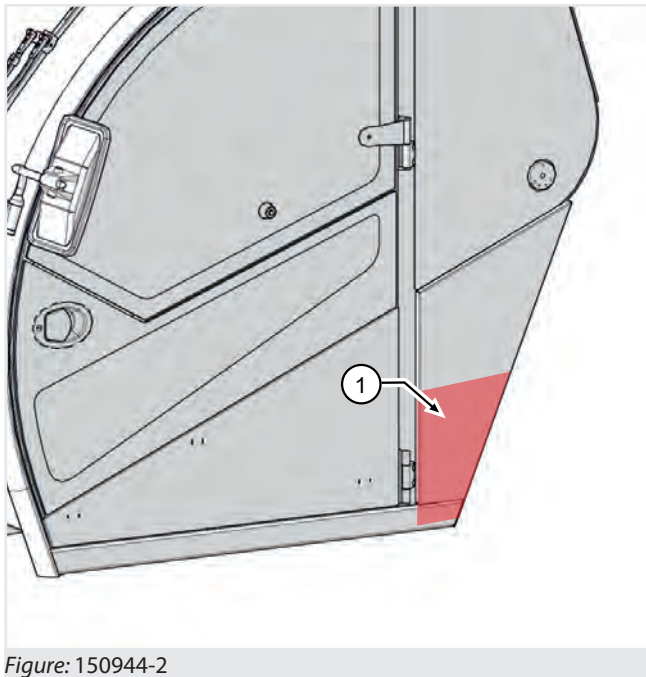

Figure: 150944-2

Clean the air intake grid (fig. 150944-2) at the end of every working day using a jet of air.



### DANGER

Do not use diesel fuel, gasoline, solvents or water to clean the cartridges, as this may damage the filtering material.



### WARNING

If the vehicle is used in environments particularly rich of dust (barns, etc.), the filter life is reduced to 100 hours.



### WARNING

**In case of malfunction of the ventilation system, check the filter clogging.**

In the event that the malfunction continues despite the filter replacement, contact DIECI service centre.



### DANGER

**Do not use the vehicle without a cab filter.**

The entry of dust into the cab may involve risks to the health of the operator and breakage of the ventilation system.

## 11.18.2 - Air conditioning: Cleaning \*



### NOTE

Air conditioning is an optional accessory.

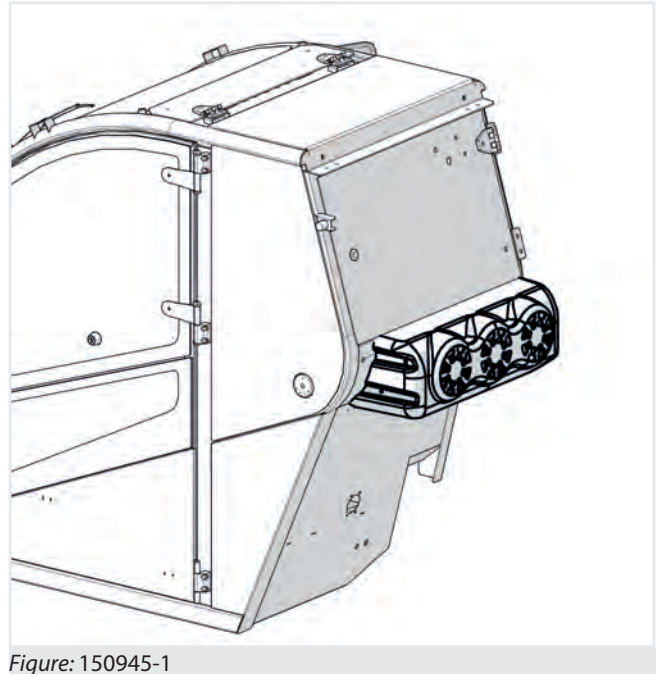

Figure: 150945-1

- Prepare the vehicle in the maintenance position.
- Remove the protection housing (fig. 150945-1).
- Clean the air conditioning radiator directing compressed air at a maximum pressure of 7 bar, from the top downwards, in the direction opposite to that of the normal flow of air. The air flow must be perpendicular to the radiator surface.
- Remove dirt from under the air conditioning radiator.
- After cleaning, refit the condenser.



### ATTENTION

**Be careful not to damage the radiator fins while cleaning.**

Check that the fins are not deformed; in that case straighten with caution.

## 11.19 - Boom maintenance

### 11.19.1 - Sliding blocks maintenance

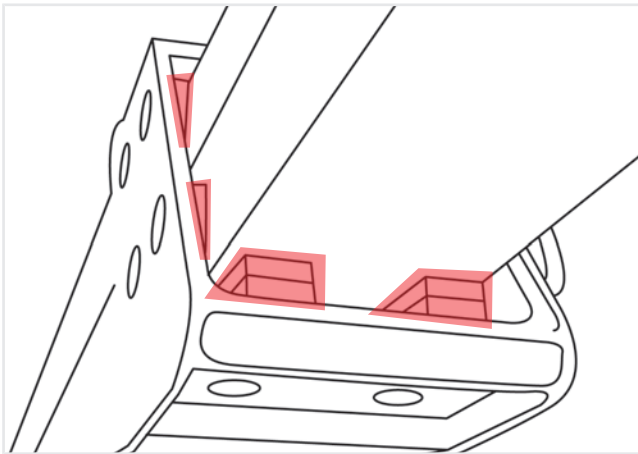

Figure: 150571-1

Worn sliding blocks can lead to oscillations and clearances between one extension and the other with consequent loss of precision in the movements and danger of load falling.

- For the deadlines see the summary table at the beginning of the chapter.
- With severe working conditions the wear is greater.



#### ATTENTION

Maintenance to the telescopic boom shoes must be performed by authorised **DIECI** service.

### 11.19.2 - Boom lubrication with grease



Figure: 150572-1

The boom sliding blocks must be kept lubricated to prevent as much as possible the deterioration and maintain soft movements.

- If the grease layer is thin or if impurities (sand, dust, shavings, etc.) are present, proceed as follows:
- Prepare the vehicle in the maintenance position.
- Turn on the vehicle.
- Fully extend the boom and keep it in horizontal position.
- Turn off the engine and remove the ignition key, place a sign in the cab showing "maintenance in progress".
- Disconnect the battery using the battery cut-off switch.
- Remove the layer of grease and impurities on the surface of the extensions with a cloth.
- Use a brush to apply a layer of approved type grease on all four sides of the extensions.
- Turn on the vehicle.
- Fully retract and extend the boom several times to evenly distribute the grease.
- Turn off the vehicle.
- Remove excess grease.



#### ATTENTION

Use only lubricants recommended by **DIECI**, different lubricants may cause severe damage to the sliding surfaces.



#### WARNING

During the grease visual check and application the vehicle must be turned off and the key removed from the cab to avoid accidental operation.



#### NOTE

**See the "Maintenance Log" chapter to know the maintenance intervals timing.**

When using the vehicle in severe conditions, very dusty environment requires a more frequent greasing.

## 11.20 - Cylinders block valves maintenance

The block valves for cylinders prevent uncontrolled movement of the pistons of the cylinders in the event of hydraulic pressure failure or bursting of a hose.

The valves are installed directly on the cylinders.



## DANGER

**During the checking operations do not allow any person to stay within the radius of action of the vehicle.**

Check the valves individually.

In case of malfunction do not use the vehicle until it has been repaired.

### Boom lifting cylinders:

- Start the engine. Make sure that the parking brake is engaged and the transmission is in neutral.
- Lift the boom to approximately 45°.
- With the engine running at 1400 rpm, lower the boom. During the boom movement stop the engine.

The boom movement must slow down and then stop when the engine slows down and stops.



## DANGER

**If the boom continues to move after stopping the engine, the lifting cylinders block valve is faulty.**

Remove the fault as soon as possible, contact the *DIECI* service centre.

### Boom extension cylinder:

- Start the engine. Make sure that the parking brake is engaged and the transmission is in neutral.
- Lift and fully extend the boom.
- With the engine running at 1400 rpm, retract the boom. During the boom movement stop the engine.

The boom movement must slow down and then stop when the engine slows down and stops.



## DANGER

**If the boom continues to move after stopping the engine, the extension cylinders block valve is faulty.**

Remove the fault as soon as possible, contact the *DIECI* service centre.

### Forks tilting cylinders:

- Start the engine, take a load on the forks (for example, a load of bricks or some bales of hay).
- Tilt the forks fully upward.
- Engage the parking brake and set the transmission into neutral.
- Tilting the boom away from the ground sufficiently to allow the forks to tilt forward.
- With the engine running at 1400 rpm, operate the control lever to tilt the plate forward. During the forks movement stop the engine.

The tilting movement must slow down and then stop when the engine slows down and stops.



## DANGER

**If the forks continue to move after stopping the engine, the tilting cylinders block valve is faulty.**

Remove the fault as soon as possible, contact the *DIECI* service centre.

### Levelling and oscillating block cylinders (if any):

- Position the vehicle on a perfectly horizontal surface.
- Make sure that the parking brake is engaged and the transmission is in neutral.
- Make sure the vehicle is in carriage mode.
- Lift the boom about 15 cm from the ground and level the vehicle so that the chassis is perfectly parallel to the surface (check the level in the cab).
- Check that, without intervening on the levelling control, the vehicle maintains this position even after a prolonged use.



## DANGER

**If the chassis continues to move after stopping the engine, the levelling cylinders block valve is faulty.**

Remove the fault as soon as possible, contact the *DIECI* service centre.



## NOTE

Do not level the vehicle with boom raised and/or removed.

Outriggers cylinders (if present)

- Start the engine. Make sure that the parking brake is engaged and the transmission is in neutral.
- Place the vehicle on outriggers.
- Level the vehicle with the outriggers.
- Fully extend the boom.
- With the engine running at idle speed, rotate the vehicle turret.



**DANGER**

**If the outriggers continue to move after stopping the engine, the outriggers cylinders block valve is faulty.**

Remove the fault as soon as possible, contact the *DIECI* service centre.

- Put back the caps and tighten down.

**When replacing the oil it is necessary to:**

- Prepare the vehicle in the maintenance position.
- Place a container for the oil recovery under the drain plug "3" to collect any leaks.
- Open the filler cap "1" and then the drain cap "3".
- Drain off all the oil.
- Close the drain plug "3".
- Load new oil from the filler cap "1", up to make oil seep out from the level cap "2".

Put back the caps and tighten down.



**WARNING**

**Replace oil in the differential axles after the first 100 hours of use.**

Failure to replace the running-in oil will compromise the correct operation of the differential axles

**11.21 - Differential Axles Maintenance**

**11.21.1 - Differential axles oil: Check and replacement**

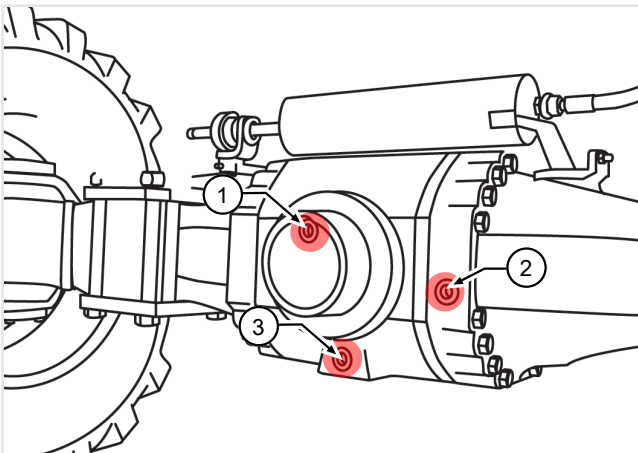

Figure: 150579-1

The filler, level and drain caps are located in the central part of the front and rear differential axle (fig. 150579-1):

**When checking the oil level it is necessary to:**

- Prepare the vehicle in the maintenance position.
- Place a container for the oil recovery under the level plug "2" to collect any leaks.
- Open the level cap "2". In the best conditions oil must seep out from the hole.
- If necessary, open the cap "1" and top up to make oil seep out from the level cap "2".

## 11.22 - Hydraulic fittings tightening torques

### Inserts with 60° nose - BSP thread

Thread	1/18.28	1/4.19	3/8-19	1/2-14	5/8-14	3/4-14	1"-11	1"1/4-11	121/2-11
(N·m)	12-14	14-16	25-28	45-60	55-70	90-110	120-140	170-190	200-245

### Inserts with 60° nose - METRIC thread

Thread	10x1	12x1.5	14x1.5	16x1.5	18x1.5	22x1.5	26x1.5	28x1.5	30x1.5
(N·m)	12-14	13-15	15-18	25-28	27-30	50-60	60-75	80-100	110-130

### SERIES DIN RANGE „L“

Thread	12x1.5	14x1.5	16x1.5	18x1.5	22x1.5	26x1.5	30.2	36x1.5	45x1.5	52x1.5
(N·m)	13-15	15-18	25-28	27-30	50-60	30-75	85-105	120-140	170-190	190-230

### SERIES DIN RANGE „S“

Thread	14x1.5	16x1.5	18x1.5	20x1.5	22x1.5	24x1.5	30x2	36x2	42x2	52x2
(N·m)	15-18	25-28	27-30	43-54	50-62	60-75	90-110	125-145	170-190	200-245



# 11.23 - Torque specifications - fasteners

## 11.23.1 - Torque specifications - fasteners: Fine pitch

	Coefficient of friction	4.8		5.8		6.8		8.8		10.9		12.9	
		Preload (N)	Tightening torque: (Nm)	Preload (N)	Tightening torque: (Nm)	Preload (N)	Tightening torque: (Nm)	Preload (N)	Tightening torque: (Nm)	Preload (N)	Tightening torque: (Nm)	Preload (N)	Tightening torque: (Nm)
<b>M8</b>	0.10	9798	10.87	12248	13.59	14697	16.31	19596	21.75	27557	30.58	33069	36.70
	0.14	9080	13.53	11349	16.91	13619	20.29	18159	27.05	25536	38.04	30643	45.65
<b>M10</b>	0.10	15297	21.13	19121	26.41	22945	31.69	30594	42.25	43023	59.42	51627	71.30
	0.14	14175	26.27	17719	32.84	21263	39.41	28350	52.55	39867	73.89	47841	88.67
<b>M10</b>	0.10	16384	22.12	20480	27.66	24575	33.19	32767	44.25	46079	62.23	55295	74.67
	0.14	15222	27.80	19027	34.75	22833	41.70	30443	55.61	42811	78.20	51373	93.84
<b>M12</b>	0.10	22021	35.83	27526	44.79	33031	53.75	44041	71.67	61933	100.78	74320	120.94
	0.14	20406	44.53	25507	55.66	30609	66.79	40812	89.06	57391	125.24	68870	150.29
<b>M12</b>	0.10	23334	37.26	29167	46.57	35001	55.88	46667	74.51	65626	104.78	78751	125.74
	0.14	21669	46.70	27087	58.38	32504	70.06	43338	93.41	60945	131.36	73134	157.63
<b>M14</b>	0.10	31610	59.04	39513	73.80	47415	88.57	63220	118.09	88903	166.06	106684	199.27
	0.14	29346	73.92	36682	92.40	44019	110.89	58692	147.85	82535	207.91	99043	249.49
<b>M16</b>	0.10	42581	89.78	53227	112.23	63872	134.67	85163	179.56	119760	252.51	143712	303.02
	0.14	39588	113.06	49485	141.32	59382	169.59	79176	226.12	111341	317.98	133609	381.57
<b>M18</b>	0.10	51457	124.03	64322	155.03	77186	186.04	102914	248.06	144723	348.83	173668	418.59
	0.14	47752	155.02	59690	193.78	71628	232.53	95503	310.05	134302	436.00	161162	523.20
<b>M18</b>	0.10	55415	130.17	69269	162.72	83123	195.26	110830	260.35	155855	366.12	187026	439.34
	0.14	51578	164.67	64472	205.84	77366	247.01	103155	329.35	145062	463.15	174075	555.77
<b>M20</b>	0.10	65534	173.72	81918	217.16	98301	260.59	131068	347.45	184315	488.60	221178	586.32
	0.14	60886	218.17	76108	272.71	91329	327.26	121772	436.34	171243	613.61	205491	736.33
<b>M20</b>	0.10	70115	181.58	87643	226.97	105172	272.36	140229	363.15	197198	51.68	236637	612.82
	0.14	65319	230.55	81649	288.19	97979	345.82	130638	461.10	183710	648.42	220452	778.10

	Coefficient of friction	4.8		5.8		6.8		8.8		10.9		12.9	
		Preload (N)	Tightening torque: (Nm)	Preload (N)	Tightening torque: (Nm)	Preload (N)	Tightening torque: (Nm)	Preload (N)	Tightening torque: (Nm)	Preload (N)	Tightening torque: (Nm)	Preload (N)	Tightening torque: (Nm)
<b>M22</b>	0.10	81221	236.88	101526	296.10	121831	355.32	162442	473.76	228433	666.23	274120	799.48
	0.14	75534	298.75	94417	373.43	113301	448.12	151068	597.49	212439	840.22	254927	1008.27
<b>M22</b>	0.10	86164	246.02	107705	307.53	129246	369.04	172329	492.05	242337	691.94	290804	830.33
	0.14	80332	313.41	100415	391.76	120498	470.11	160664	626.82	225933	881.46	271120	1057.75
<b>M24</b>	0.10	98516	308.56	123145	385.70	147773	462.84	197031	617.12	277075	867.83	332490	1041.40
	0.14	91693	390.33	114617	487.92	137540	585.50	183387	780.67	257887	1097.82	309465	1317.38
<b>M24</b>	0.10	104079	319.62	130099	399.52	156119	479.43	208152	639.23	292723	898.92	351268	1878.71
	0.14	97096	408.12	121370	510.15	145644	612.18	194192	816.24	273083	1147.84	327699	1377.41
<b>M27</b>	0.10	127922	448.43	159903	560.54	191884	627.65	255845	896.87	359782	1261.22	431738	1513.46
	0.14	119185	569.67	148981	712.09	178778	854.51	238370	1139.34	335208	1602.20	402250	1922.64
<b>M30</b>	0.10	16818	623.80	201022	779.75	241226	935.70	321635	1247.60	452299	1754.43	542759	2105.32
	0.14	149957	795.14	187446	993.93	224936	1192.72	299914	1590.29	421754	2236.34	506105	2683.61

## 11.23.2 - Torque specifications - fasteners: Coarse pitch

	Coefficient of friction	4.8		5.8		6.8		8.8		10.9		12.9	
		Preload (N)	Tightening torque: (Nm)	Preload (N)	Tightening torque: (Nm)	Preload (N)	Tightening torque: (Nm)	Preload (N)	Tightening torque: (Nm)	Preload (N)	Tightening torque: (Nm)	Preload (N)	Tightening torque: (Nm)
<b>M3</b>	0.10	1220	0.54	1525	0.68	1830	0.82	2440	1.09	3431	1.53	4117	1.84
	0.14	1126	0.60	1407	0.83	1689	1.00	2252	1.34	3167	1.88	3800	2.26
<b>M3.5</b>	0.10	1638	0.84	2048	1.05	2457	1.26	3276	1.68	4608	2.36	5529	2.84
	0.14	1511	1.03	1889	1.28	2267	1.54	3023	2.05	4251	2.89	5101	3.47
<b>M4</b>	0.10	2115	1.25	2644	1.56	3173	1.88	4231	2.50	5950	3.52	7140	4.22
	0.14	1951	1.53	2439	1.91	2926	2.29	3902	3.06	5487	4.30	6584	5.16
<b>M5</b>	0.10	3462	2.46	4327	3.08	5192	3.70	6923	4.93	9736	6.93	11683	8.32
	0.14	3197	3.02	3996	3.78	4795	4.53	6394	6.04	8991	8.50	10789	10.20
<b>M6</b>	0.10	4875	4.24	6093	5.30	7312	6.35	9749	8.47	13710	11.92	16452	14.30
	0.14	4499	5.19	5624	6.48	6749	7.78	8998	10.37	12654	14.59	15184	17.51
<b>M7</b>	0.10	7135	6.97	8918	8.71	10702	10.45	14269	13.94	20066	19.60	24079	23.52
	0.14	6600	8.60	8250	10.76	9899	12.90	13199	17.21	18561	24.20	22274	29.04
<b>M8</b>	0.10	8947	10.20	11184	12.75	13421	15.30	17894	20.41	25164	28.70	30197	34.44
	0.14	8266	12.54	10332	15.67	12398	18.80	16531	25.07	23247	35.26	27897	42.31
<b>M10</b>	0.10	14245	20.11	17806	25.14	21367	30.16	28489	40.22	40063	56.56	48075	67.87
	0.14	13167	24.76	16459	30.95	19751	31.14	26335	49.52	37033	69.64	44440	83.56
<b>M12</b>	0.10	20767	34.43	25958	43.03	31150	51.64	41533	68.86	58406	96.83	70087	116.20
	0.14	19204	42.42	24005	53.03	28806	63.63	38408	84.84	54011	119.31	64814	143.17
<b>M14</b>	0.10	28390	54.77	35487	68.46	42585	82.15	56780	109.53	79847	154.03	95816	184.84
	0.14	26261	67.56	32827	84.45	39392	101.34	52522	135.13	73860	190.02	88632	228.03
<b>M16</b>	0.10	39242	85.14	49053	106.43	58863	127.72	78484	170.29	110369	239.47	132442	287.36
	0.14	36364	105.80	45455	132.26	54546	158.71	72729	211.61	102274	297.58	122729	357.09
<b>M18</b>	0.10	47533	117.48	59416	146.85	71300	176.22	95066	234.96	133687	330.41	160424	396.49
	0.14	43986	145.16	54983	181.45	65979	217.74	87972	290.32	123711	402.26	148453	489.92
<b>M20</b>	0.10	61238	166.08	76548	207.61	91857	249.13	122476	332.17	172232	467.11	206678	560.54

	Coefficient of friction	4.8		5.8		6.8		8.8		10.9		12.9	
		Preload (N)	Tightening torque: (Nm)	Preload (N)	Tightening torque: (Nm)	Preload (N)	Tightening torque: (Nm)	Preload (N)	Tightening torque: (Nm)	Preload (N)	Tightening torque: (Nm)	Preload (N)	Tightening torque: (Nm)
	0.14	56747	206.39	70934	257.98	85121	309.58	113494	412.78	159601	580.47	191522	696.56
<b>M22</b>	0.10	76305	227.22	95382	284.02	114458	340.82	152610	454.43	214608	639.05	257530	766.85
	0.14	70792	283.79	88490	352.74	106188	425.69	141584	567.58	199102	798.16	238923	957.80
<b>M24</b>	0.10	88232	287.16	110291	358.94	132349	430.73	176465	574.31	248154	807.63	297784	969.15
	0.14	81762	356.84	102202	446.05	122643	535.26	163524	713.68	229955	1003.61	275946	1204.33
<b>M27</b>	0.10	115779	420.40	144724	525.05	173668	930.06	231558	840.08	325628	1181.36	390753	1417.63
	0.14	107442	525.08	134302	656.35	161162	787.62	214883	1050.16	302179	1476.79	362615	1772.15
<b>M30</b>	0.10	141000	572.83	176249	716.03	211499	859.24	281999	1145.65	396561	1611.08	475873	1933.29
	0.14	130771	714.49	163463	893.11	196156	1071.73	261541	1428.97	367792	2009.49	441351	2411.39

Local Dealers can supply original spare parts as well as advice and instructions for their installation and use.

Use only original spare parts when they are required.

The use of non-original spare parts may cause damage to other parts of the vehicle. Customers are advised to purchase all original spare parts required only from an authorized Agent or Dealer.

*DIECI s.r.l.* does not consider itself liable for damage deriving from the use of non-original spare parts.

## 12.1 - Spare part supply

*DIECI s.r.l.* guarantees the supply of original spare parts or alternatives for 10 years from the date of the last model produced of the series concerned.

## 12.2 - Assistance to owner / operator

In order to obtain a good service from your Dealer, please obtain these fundamental data before contacting the service center:

1. Specify your name, address and telephone number.
2. Indicate the model and VIN.
3. Indicate the date of purchase and the hours of operation.
4. Explain the nature of the fault.

Note that only DIECI Dealers can access the resources at DIECI site for customer service. Moreover, they are able to offer a variety of programs with regard to warranty, maintenance at a fixed price, safety checks, including tests

## 12.3 - Technical Assistance Service address

### Dieci Technical Assistance Service

Via E. Majorana, 2/4

42027 Montecchio Emilia (RE) ITALY

Tel. +39 0522 869611

Fax +39 0522 869744

service@dieci.com



## WARNING

The interventions for the elimination of faults can only be carried out by trained personnel.

Do not work on failures if the "Safety regulations", "Safe Working Procedures" and "MAINTENANCE" have not been read and understood before.





This symbol indicates that the trouble experienced may NOT be resolved without the intervention of a **DIECI** Service authorized workshop

## 13.1 - Engine



PROBLEM	CAUSE	SOLUTION	
It does not set in motion	Direction of travel lever engaged	Place the lever in neutral	
	Parking brake deactivated	Activate it	
	No fuel	Fill the tank	
	Battery isolation switch disconnected	Connect the battery isolation switch	
	Low Battery	Recharge the battery or replace it	
	Fuse failure	Replace the fuse	
	Other	Consult the Use and Maintenance manual of the engine	

## 13.2 - Hydraulic transmission system



PROBLEM	CAUSE	SOLUTION	
The vehicle does not go in any direction	Insufficient hydraulic oil level	Check the hydraulic oil level	
	Hand throttle engaged	Disengage the hand throttle	
	The sensor built-in the seat does not report the presence of the operator	Sit properly at the driver's seat	
	The movement selection lever is not engaged	Engage the lever to the desired position	
	The outriggers are lowered (if installed)	Raise all outriggers fully up	
	Parking brake in operation	Disengage the brake	
	Electrical circuit failure	Repair the circuit	
	Hydrostatic transmission failure	Repair or replace the transmission	
The vehicle loses speed	The transmission ByPass tap has been opened (if installed)	Close the ByPass tap	
	Hydraulic oil intake filter clogged	Remove the oil filter and replace it	
	Inching pedal failure	Check the correct operation of the pedal and of the valve	





### 13.3 - Brakes

PROBLEM	CAUSE	SOLUTION	
The vehicle does not brake	Lack of oil in the oil - brakes tank	Refill the tank and / or Purge the system	
	Loss of fluid from the circuit	Check for leaks	
	Brake discs worn	Replace the brake discs	
	Brake master cylinder failure	Repair or replace	
	Unsuitable fluid in the circuit or in the differential sump	Check the brake oil specifications indicated	

### 13.4 - Steering wheel

TROUBLE	CAUSE	SOLUTION	
The machine runs sideways The wheels are not aligned	The wheels are not correctly aligned	Align them	
	Steering selection error	Put back the lever in a different steering mode	
	Control distributor failure	Repair or replace the distributor	
	Leakage from the steering wheel hydraulic cylinders	Replace the gaskets	

### 13.5 - Telescopic boom

TROUBLE	CAUSE	SOLUTION	
The vehicle does not lift the load	They safety systems have activated	See the "Anti-tipping device" chapter	
	Electrical system failure	Check the fuses and electrical system	
	Hydraulic oil level in the tank insufficient	Top up	
	Relative hydraulic pump failure	Repair or replace the pump	
	Distributor low calibration	Check and re-calibrate the distributor	
	Lifting cylinders internal leak	Replace the gaskets	
The boom does not extend	"The safety systems have activated (Indicator light and audible alarm in operation)"	See the "Anti-tipping device" chapter	

TROUBLE	CAUSE	SOLUTION	
The boom does not come down	"The safety systems have activated (Indicator light and audible alarm in operation)"	See the "Anti-tipping device" chapter	

Cleaning the vehicle and all its components is fundamental for it to be kept in proper working order.

## 14.1 - Machine cleaning

Proceed as follows for a correct cleaning process:

- Switch the engine off, remove the ignition key and wait until the various components cool down.
- Wear the suitable protective clothing (gloves, masks, overalls, etc.).
- Do not use flammable liquids, acids or products that may chemically attack the vehicle components.
- Use water to soften dirt that sticks to the surface.
- Ask your **DIECI** dealer for touch-up paint to repair minor defects in the vehicle bodywork.
- Check that all the safety stickers are present. Replace any that have been lost or removed for cleaning purposes.
- Use a pressure washer to clean the external part of the vehicle and the engine compartment, bearing the following in mind:
  - Make sure the top-up caps (radiator, oil tank, fuel tank, etc.) are closed well.
  - Protect the control boxes and connectors from water infiltrations.
  - Do not operate with a pressure and water temperature that exceeds 100 bar and 80°, respectively.
  - Hold the washer nozzle at a minimum distance of 40 cm from the relative surface.
  - Do not direct the jet at any single point but wash with wide strokes.
  - The inside of the vehicle is delicate and cannot be cleaned with a pressure washer.

### Electrical components

- If a pressurized jet is used, try not to wet the electrical components, such as the alternator and the starter motor.
- If water accidentally falls into the electrical system, it could cause the vehicle to malfunction.
- Do not use water or steam to clean the electrical system, sensors and connectors.

### Mechanical Components

- Do not clean the moving elements or hot surfaces, allow all parts to cool as a temperature change could damage them.

## 14.2 - Glasses cleaning

- The cab windows, lights and rear view mirrors must be washed often with soapy water.
- After washing has been completed, dry thoroughly; do not leave any stains or marks which may limit or obstruct the driver's visibility.

## 14.3 - Cleaning the cab

- Clean soft upholstery in the cab with a cloth that has been dipped in a solution of water and detergent and then thoroughly wrung.
- The driver's seat and the floor must be cleaned with a vacuum cleaner and/or a stiff brush. If necessary, use a damp cloth to remove any stubborn stains.
- Clean the seat belt with a sponge that has been soaked in hot soapy water, and let it dry on its own.
- Fabric-covered seats must be cleaned with a stiff brush or vacuum cleaner. Plastic seats must be cleaned with a damp cloth.



### WARNING

#### Pay attention to electrical components.

Do not use water jets inside the cab.



### WARNING

Do not use products containing alcohol to clean the interior lining of the cab.

## 14.4 - Safety stickers cleaning



### ATTENTION

To ensure proper interpretation verify that they are in the correct position and that they are always kept clean.

Clean the safety stickers when they are dirty, covered with mud, concrete or debris.



### WARNING

**It is absolutely forbidden to clean the messages on the vehicle and equipment using solvents or gasoline.**

The stickers may become discolored. The stickers in addition to those of care and safety must always be treated in the same way.



## DANGER

**Always check the good condition of the anchors (ropes, chains, wedges, etc...).**

Make sure that the lifting equipment is adequate for the weight of the vehicle to be lifted.

**NOTE!** The weight and dimensions of the vehicle are shown in the “Technical data” chapter; check the overall dimensions for the maximum and minimum height values from the ground and the weight allowed.

The vehicle is fitted with lifting points, marked by special symbols (fig. 150522-1).

Attach the ropes at the points indicated in the figure, paying utmost attention during the lifting phases. Slowly proceed with the lifting.

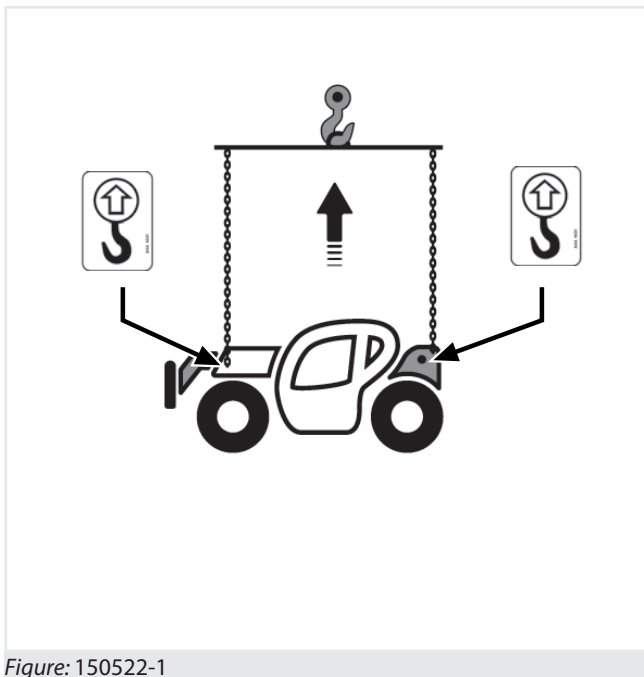

Figure: 150522-1



## DANGER

Before lifting the vehicle, make sure no unauthorized personnel are in the surrounding area.



## ATTENTION

Lifting cables with a minimum unit capacity of 6 tons (13220 lb) are required.

Before lifting the vehicle, make sure to:

- Remove any attachments installed on the vehicle.

- Retract and lower the telescopic boom completely.
- Engage the parking brake, place and the movement selection lever at “N” and switch off the vehicle.
- Close all windows and the cab door.



**WARNING**

Always check the good condition of the anchors (ropes, chains, wedges, etc...).

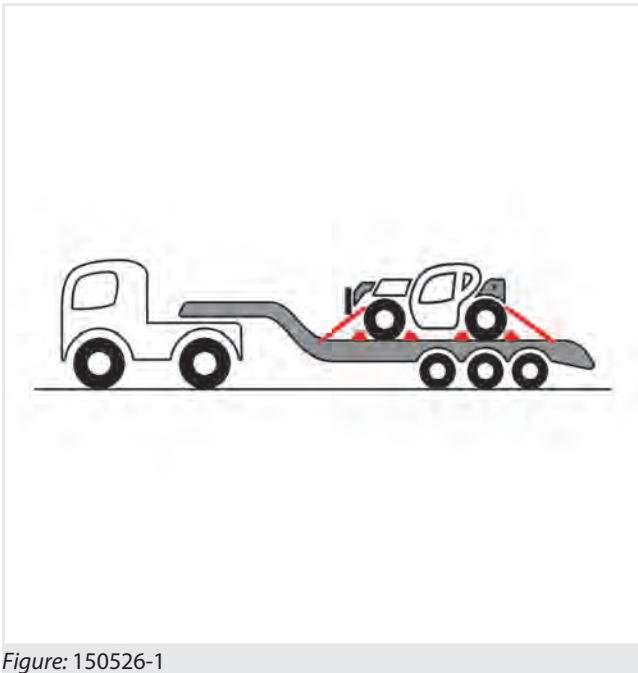

Figure: 150526-1

**NOTE!** The weight and dimensions of the vehicle are shown in the “Technical data” chapter; check the overall dimensions for the maximum and minimum height values from the ground and the weight allowed.

Pay attention to the following when loading the vehicle onto a trailer:

- Before using ramps or trailers to load the vehicle on, remove any mud, ice or oil that could cause accidents.
- Check that the axle and the transport vehicle can withstand the overall weight of the vehicle and any loaded equipment.
- Check the overall dimensions of the vehicle for minimum and maximum heights from the ground and the weight allowed.
- Carefully handle the vehicle onto the transport vehicle.
- Make sure local regulations are observed when transporting the vehicle on public roads.



**DANGER**

When loading or unloading a vehicle from a transport vehicle, there is always the risk of the vehicle overturning sideways; therefore, have another person on the ground to control the operations.

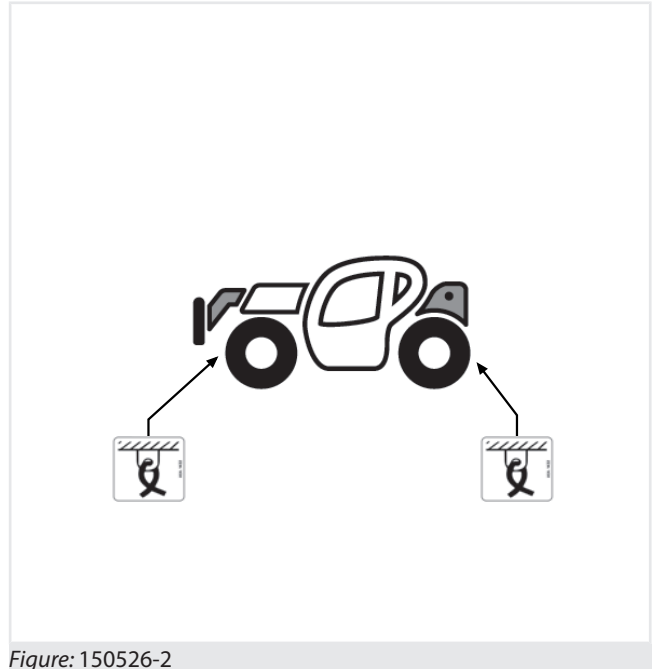

Figure: 150526-2

Take the following precautions when loading or unloading a vehicle:

1. Choose solid and level ground.
2. Remove any attachments installed on the vehicle.
3. Lower and fully retract the telescopic boom
4. Use a platform or a ramp.
5. Always select the slowest speed.
6. Load the vehicle on to the transport vehicle, making sure that the ramps are positioned properly and safely.
7. Once the vehicle is in a safe position, switch the engine off and engage the parking brake.
8. Close all windows and the cab door.
9. Anchor the vehicle to the transport vehicle with chains or cables through the relative hooks (fig. 150526-2).
10. Apply wedges to the front and rear wheels of the transport vehicle.

## 17.1 - Long period of inactivity

If the vehicle must be stored for a long period of time (over a week), certain precautions must be complied with to protect it:

- Clean the vehicle.
- Lubricate all the greasers.
- Check the tires and inflate them to the recommended pressure.
- Clean the fuel system and change the filter cartridges.
- Store any equipment.
- Use the battery cut-off switch to deactivate the electrical circuit.
- Realign and lower all the mobile parts of the vehicle completely.
- Close and lock all the windows.
- Close and lock the door.

## 17.2 - Long period of inactivity

If the machine must be stored for a long period (more than two months), certain precautions must be complied with to protect it:

- Clean the vehicle.
- Touch up the paint where necessary to prevent rust.
- Lubricate all the greasers.
- Check whether any parts are worn or damaged and replace them, if necessary.
- Check the tires and inflate them to the recommended pressure.
- Drain the oil from the engine and replace it with new oil.
- Clean the fuel system and change the filter cartridges.
- Empty the fuel tank as usual and fill it with ten liters of special fuel for prolonged inactivity. Run the engine for ten minutes so the new solution can distribute evenly.
- Store any equipment.
- Use the battery cut-off switch to deactivate the electrical circuit.
- Realign and lower all the mobile parts of the vehicle completely.
- Apply a layer of light grease on the uncovered rods of the hydraulic cylinders.
- Cover the exhaust opening.
- Close and lock all the windows.

- Close and lock the door.

## 17.3 - Restarting the vehicle

Preparing the vehicle after a long period of inactivity:

- Inflate the tires to the correct pressure.
- Remove the jack stands from under the axles.
- Fill the fuel tank.
- Check the radiator coolant level.
- Check the level of the various oils.
- Fit a fully charged battery.
- Remove the cover of the exhaust pipe.
- Remove the layer of grease on the exposed cylinder rods.
- Start the engine and check that all the controls work properly.
- Let the engine run for a few minutes.
- Verify the efficiency of the brake system.



- Waste material should not be dispersed in the environment but rather disposed of appropriately. Used lubricants, batteries, rags dirty with grease, brake pads etc. should be handed over to specialized companies authorized to dispose of polluting waste.
- Improper waste disposal poses a threat to the environment. The following are potentially dangerous waste: lubricants, fuel, cooling, filters and batteries.
- Do not spill or pour waste onto the ground, into the sewers or into water beds.
- Contact your local authority or collection centers for information for how to recycle or dispose of waste properly.

## 18.1 - Ecological considerations

A few helpful recommendations are listed below. Learn about current legislation in force in your country.

Ask suppliers for information about lubricating oils, fuels, antifreeze products, detergents, etc., about their effects on people and on the environment as well as on information regarding the regulations to be observed when using, stocking and disposing of such products.

- Do not refill the tanks using unsuitable jerry cans or pressurized combustible fueling systems as they may cause leaks and loss of significant amounts of liquid.
- Modern lubricating oils contain additives. Do not burn contaminated combustible oils and/or oils used in conventional heating systems.
- Take care not to spill used engine cooling fluids, engine and transmission lubricating oils, hydraulic oil, brake oil etc. while pouring or draining them. Store them safely and, when it is time, dispose of them in compliance with current legislation or with local facilities.
- Modern antifreeze liquids and their solutions, such as antifreeze and other additives should be replaced every two years. Make sure such liquids are not absorbed by the soil; they should be collected and disposed of appropriately.
- Do not intervene directly with the air conditioning systems (Optional), by opening them. These systems contain gas which must not be released into the atmosphere. Contact your dealer or an expert who has the necessary special equipment and who would, in any case, have to refill the system.
- Immediately repair any leaks or faults in the cooling or engine hydraulic systems.

## 18.2 - Protect the environment

It is illegal to pollute sewers, water sources or soil. Use only authorized dumping grounds centers, including the areas designated by the local authorities or workshops equipped with the necessary tools for the disposal of used oils. If in doubt, contact your local authority for relevant instructions.

To demolish the vehicle or the equipment, dismantle all components and keep the different types of materials separate for sending to the relative collection centers.

The following types of materials may be present:

- Ferrous materials (carpentries and mechanical components)
- Plastic materials (gaskets, belts, protections)
- Electric materials (cables, windings and similar)
- Oils and lubricants (hydraulic oil, reduction gear lubricants, lubricating greases)

## 20.1 - Components legend

Name	Sheet	Function
A149	LEFT SPEAKER	10
A150	RIGHT SPEAKER	10
A151	RADIO	10
A241	ANTI-TIPPING SYSTEM	5
A265	FLASHER CONTROL UNIT	8
A283	CAN LINK	3
A681	DENOX CONTROL UNIT	1
A681	DENOX CONTROL UNIT	7
A681	DENOX CONTROL UNIT	3
A690	ECU IVECO	1
A690	ECU IVECO	3
A690	ECU IVECO	7
B130	SEAT MICRO	4
B138	INCHING MICROSWITCH	2
B139	STOP LIGHTS MICROSWITCH	8
B181	TRANSMISSION DISCONNECT MICROSWITCH	4
B182	AIR CONDITIONED TEMPRATURE SWITCH	11
B192	BRAKES OIL LEVEL SENSOR	7
B503	HORN	8
B512	FUEL LEVEL SENSOR	7
B513	CLOGGED HYDRAULIC OIL FILTER SENSOR	7
B534	ENGAGED GEAR MICROSWITCH	4
B535	2nd GEAR PRESSURE SWITCH	4
B543	ENGINE OIL TEMPERATURE	12
B544	EXTENSION SENSOR	6
B554	NEGATIVE BRAKE PRESSURE SWITCH	4
B558	FRONT AXLE ALIGNMENT PROXIMITY SWITCH	7
B559	AXLE LOAD CELL	5
B560	REAR AXLE ALIGNMENT PROXIMITY SWITCH	7
B585	SPEED SENSOR	7
B638	AIR FILTER SENSOR	7
B643	CLOSED BOOM MICROSWITCH	5
B669	ENGINE WATER TEMPERATURE	12
B679	TEMP. SENSOR UREA LEVEL	1
B682	TEMP. SENSOR AFTER THE CATALYST	7
B683	DENOX SENSOR	3
B684	TEMP. SENSOR BEFORE THE CATALYST	7
B686	HUMIDITY SENSOR	7
B687	DC-DC CONVERTER	1
B688	DIESEL DECANTING	7
B762	30° BOOM MICROSWITCH	6
B763	15° BOOM MICROSWITCH	6

Name	Sheet	Function
B79	BRAKES OIL CIRCUIT PRESSURE SWITCH	7
E102	RIGHT FRONT WORK LIGHT	10
E103	RIGHT REAR WORK LIGHT	10
E104	LEFT FRONT WORK LIGHT	10
E118	LEFT REAR WORK LIGHT	10
E127	ROTATING LIGHT	9
E147	OVERHEAD LIGHT	10
E522	RIGHT REAR HEADLIGHT	8
E524	LICENSE PLATE LIGHT	8
E526	LEFT FRONT HEADLIGHT	8
E548	LEFT REAR HEADLIGHT	8
E551	RIGHT FRONT LIGHT	8
F10	SWITCH LIGHTING FUSE	4
F11	FRONT RIGHT AND LEFT REAR SIDELIGHTS FUSE	8
F11G	THERMOSTARTER RELAY FUSE	1
F12	LICENSE PLATE LIGHTS AND HEADLIGHTS FUSE	8
F12G	FUSE +30 ALTERNATOR	1
F14	SAR CONTROL UNIT FUSE	5
F15	INT. FUSE REMOTE CONTROL SWITCH AND ROTATING LAMP	2
F16	STOP LIGHTS MICROSWITCH FUSE	8
F17	WORK LIGHTS SWITCH FUSE	9
F18	FUSE +15 RADIO REMOTE CONTROL	2
F184	HEATING SELECTOR FUSE	11
F19	FUSE +15 BASKET KEY	2
F2	FUSE +30 WARNING	8
F201	START FUSE	1
F202	PREHEATING FUSE FILTER	1
F204	FUSE +30 ECU IVECO	1
F205	SCR CONTROL UNIT FUSE	1
F206	DENOX FUSE	1
F207	FUSE +30 CAB	1
F208	DC-DC CONVERTER FUSE	1
F209	IVECO DIAGNOSTICS FUSE	3
F209	FUSE +30 CAB	1
F21	STEERING WHEEL SELECTOR RELAY FUSE	6
F22	RIGHT AND LEFT REAR WORK LIGHT RELAY FUSE	10
F23	FUSE +30 STALK SWITCH - LIGHTS AND OVERHEAD LIGHT SWITCH	8
F25	POWER SOCKET FUSE	7
F27	REVERSING LIGHTS AND BUZZER RELAY FUSE	4
F28	30° BOOM CONSENT RELAY FUSE	6
F29	BOOM SUSPENSION CONSENT RELAY FUSE	6
F3	LOW BEAM LIGHTS FUSE	8
F31	TRANSMISSION DISCONNECTION RELAY FUSE	4

Name	Sheet	Function
F34	OPTIONAL SUPPLIES AND PNEUMATIC SEAT MOTOR FUSE	12
F35	FRONT WIPER MOTOR FUSE	8
F36	FUSE + 15 REAR WIPER-RADIO-ANTENNA	10
F37	FUSE +15 TOOL SERVICES	7
F38	OPTIONAL CENTRING HANDLER FUSE	12
F39	SUPPLY RELAY FUSE UDCI DANFOSS	6
F4	POWER SOCKET FUSE	10
F40	FANS REVERSING BUTTON FUSE	12
F41	FUSE +15 MUSHROOM-HEAD EMERGENCY PUSHBUTTON	2
F42	FUSE +15 STARTER ANTI-RESTART-. GEAR SWITCH POWER SUPPLY	2
F43	INCHING MICROSWITCH FUSE	2
F5	HIGH BEAM LIGHTS FUSE	8
F50	FUSE VP MC2M	11
F51	EVAPORATOR FAN FUSE	11
F7	RIGHT AND LEFT FRONT WORK LIGHT RELAY FUSE	10
F8	HORN RELAY FUSE	8
G0	BATTERY	1
G529	ALTERNATOR	1
H291	AFTER RUN PILOT LIGHT	1
H502	REVERSE GEAR BUZZER	8
K1	STARTER ANTI-RESTART CONTROL UNIT	2
K11	STARTUP FROM BASKET RELAY	2
K12	SERVICES CONSENT RELAY	1
K13	LEVELLING FROM ANTI-TIPPING CONSENT RELAY	6
K14	RELAY NOT USED	12
K15	NEUTRAL GEAR STARTUP CONSENT RELAY	4
K153	SERVICES RELAY	1
K16	NEUTRAL GEAR RELAY	4
K17	ENGINE STOP RELAY	1
K173	EVAPORATOR FAN RELAY	11
K19	RIGHT AND LEFT REAR WORK LIGHT RELAY	10
K2	TIMER CONTROL UNIT	4
K20	STEERING WHEEL SELECTOR RELAY	6
K21	BASKET WARNING LIGHT CONSENT RELAY	6
K22	30° BOOM CONSENT RELAY	6
K24	TRANSMISSION DISCONNECT RELAY	4
K25	2nd PUMP AND DEADMAN RELAY	6
K26	LOW BOOM RELAY	6
K27	30° BOOM RELAY CONSENT RELAY	6
K28	AUX PUMP SV RELAY	6
K29	REVERSING LIGHTS AND REVERSING BUZZER RELAY	4
K3	OPTIONAL CENTRING HANDLER RELAY	12
K30	FORWARDS GEAR RELAY	4

Name	Sheet	Function
K31	REVERSE GEAR RELAY	4
K5	HORN RELAY	8
K530	STARTUP RELAY	1
K531	DIESEL FUEL PREHEATING RELAY	1
K547	THERMOSTARTER RELAY	1
K6	RIGHT AND LEFT FRONT WORK LIGHT RELAY	10
K672	24V CONVERTER RELAY	1
K673	12V CONVERTER RELAY	1
K8	HIGH BEAM LIGHTS RELAY	8
K9	LOW BEAM LIGHTS RELAY	8
M112	FRONT WINDOW WIPER MOTOR	8
M117	WINDOW WASHER FRONT PUMP	8
M119	WINDOW WASHER REAR PUMP	10
M122	REAR WIPER MOTOR	10
M129	HEATING MOTOR	11
M152	PNEUMATIC SEAT	12
M520	STARTER MOTOR	1
M555	AIR CONDITIONED COMPRESSOR	11
P101	INSTRUMENT PANEL	4
P101	INSTRUMENT PANEL	8
P101	INSTRUMENT PANEL	7
P101	INSTRUMENT PANEL	3
P101	INSTRUMENT PANEL	12
P101	INSTRUMENT PANEL	5
P101	INSTRUMENT PANEL	6
P101	INSTRUMENT PANEL	1
R0	GRID HEATER	1
R233	ACCELERATOR PEDAL	5
R533	FILTER PRE-HEATER	1
R563	CAN LINE END HEATING ELEMENT	3
S0	BATTERY ISOLATION SWITCH	1
S106	REAR WORK LIGHTS SWITCH	9
S108	WARNING SWITCH	8
S109	LEVELING BUTTON	6
S110	MANUAL GEAR SHIFT BUTTON	4
S111	BOOM HEAD SOLENOID VALVE SWITCH	6
S115	ROTATING LIGHT SWITCH	9
S120	REAR WINDOW WIPER AND WASHER SWITCH	10
S121	PARKING BRAKE SWITCH	4
S126	FAN SPEED SELECTOR	11
S136	WHEELS ALIGNMENT BUTTON	6
S137	GEARS COLUMN SWITCH	4
S140	LIGHTS COLUMN SWITCH	8



Name	Sheet	Function
S141	STARTER PANEL	2
S143	REMOTE CONTROL SWITCH	2
S145	A/C SWITCH	11
S146	KEY FOR OPERATIONS RESTORING	5
S148	FRONT WORK LIGHTS SWITCH	9
S169	BOOM SUSPENSION SWITCH	6
S171	FAN REVERSING BUTTON	12
S202	STEERING WHEEL SELECTOR SWITCH	6
S203	LIGHTS SWITCH	9
S204	CAB MUSHROOM-HEAD EMERGENCY PUSHBUTTON	2
S206	BOOM WORK LIGHT SWITCH	9
S226	WHEELS ALIGNMENT RESET/CHECK BUTTON	6
S227	ACCELERATOR SWITCH	2
S243	WORK MODE SELECTOR	5
S303	QUICK COUPLING BUTTON	5
S326	ECO/NORMAL SWITCH	2
W177	ANTENNA	10
X165	CIGARETTE LIGHTER RECEPTACLE	10
X283	CAN BUS NODE	3
X284	CAN BUS NODE	3
X285	CAN BUS NODE	3
X286	CAN BUS NODE	3
Y516	1st MANUAL GEAR SOLENOID VALVE	4
Y518	LEFT LEVELLING SOLENOID VALVE	6
Y519	RIGHT LEVELLING SOLENOID VALVE	6
Y521	2nd MANUAL GEAR SOLENOID VALVE	4
Y523	PARKING BRAKE SOLENOID VALVE	4
Y527	FORWARD GEAR SOLENOID VALVE	4
Y528	REVERSE GEAR SOLENOID VALVE	4
Y580	CRAB STEERING WHEEL SV	4
Y581	CONCENTRIC STEERING WHEEL/CRAB SHARED SV	4
Y582	CONCENTRIC STEERING WHEEL SV	4
Y583	FRONT STEERING WHEEL SV	4
Y680	UREA HEATING SOLENOID VALVE	1
Y685	UREA DOSING SOLENOID VALVE	1
Y760	RADIATOR SOLENOID VALVE	12

# 20.2 - Wiring diagram sheets

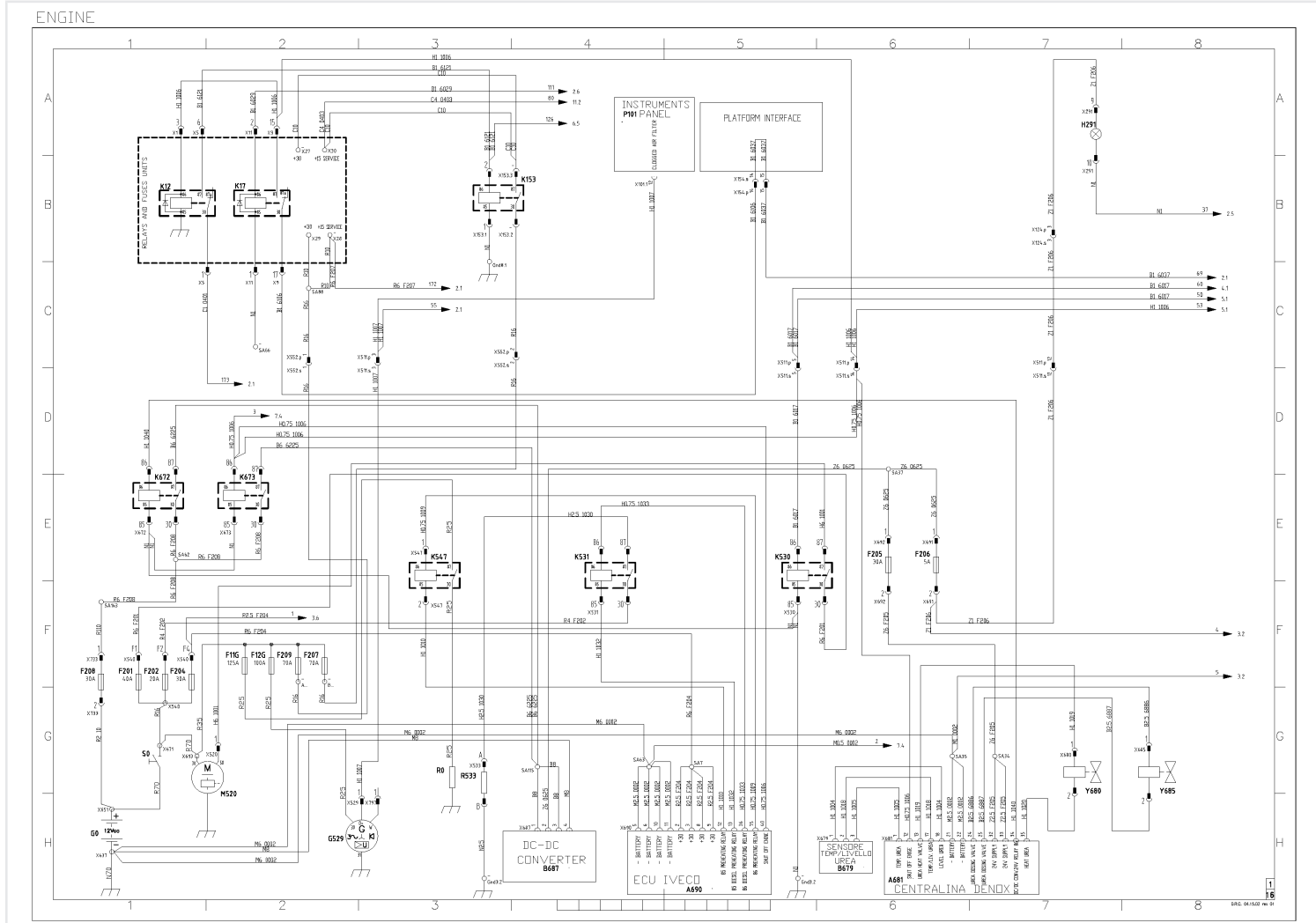

Figure: Wiring diagram - Hercules FPT - 20151006\_Page\_01



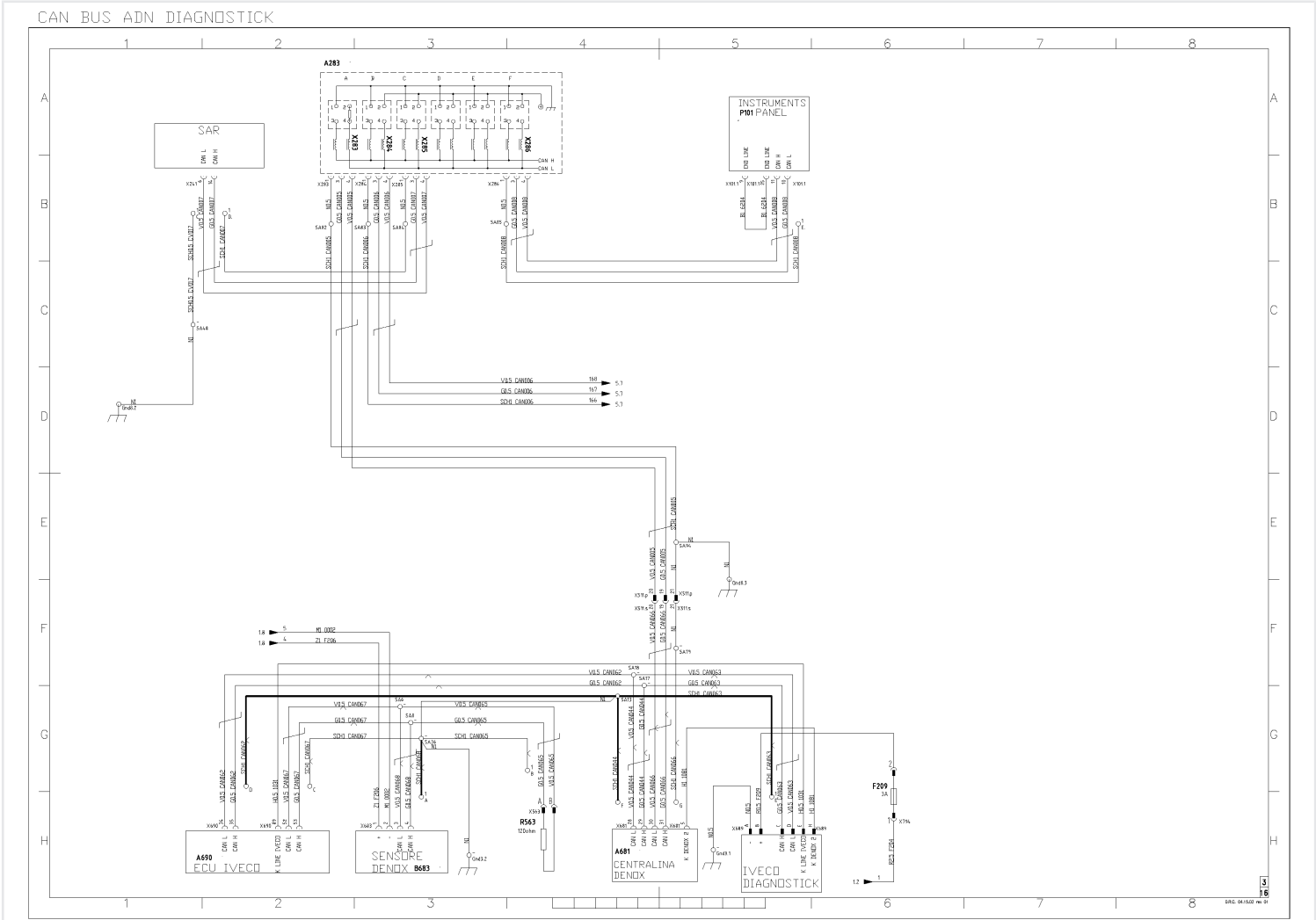

Figure: Wiring diagram - Hercules FPT - 20151006\_Page\_03

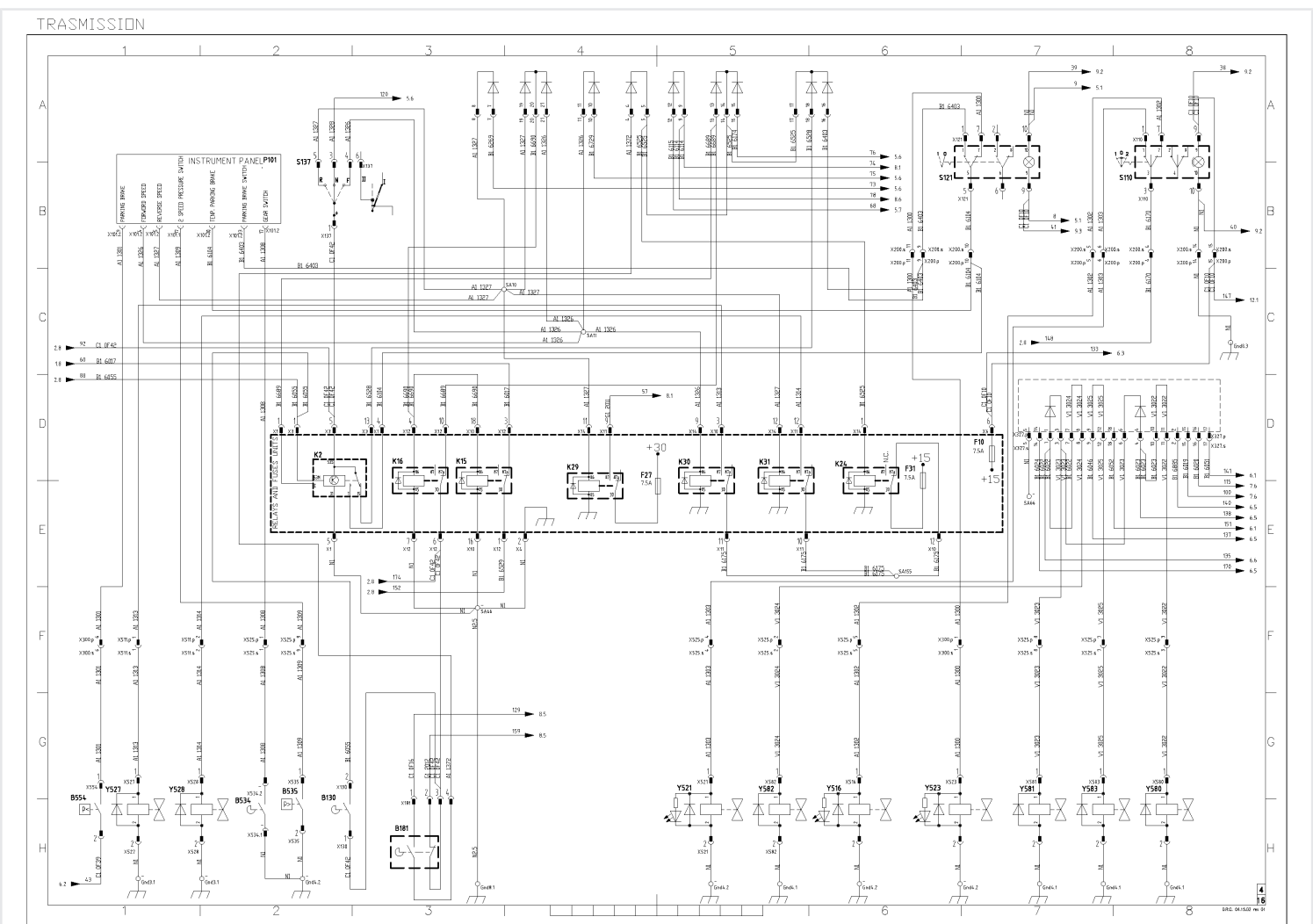

Figure: Wiring diagram - Hercules FPT - 20151006\_Page\_04

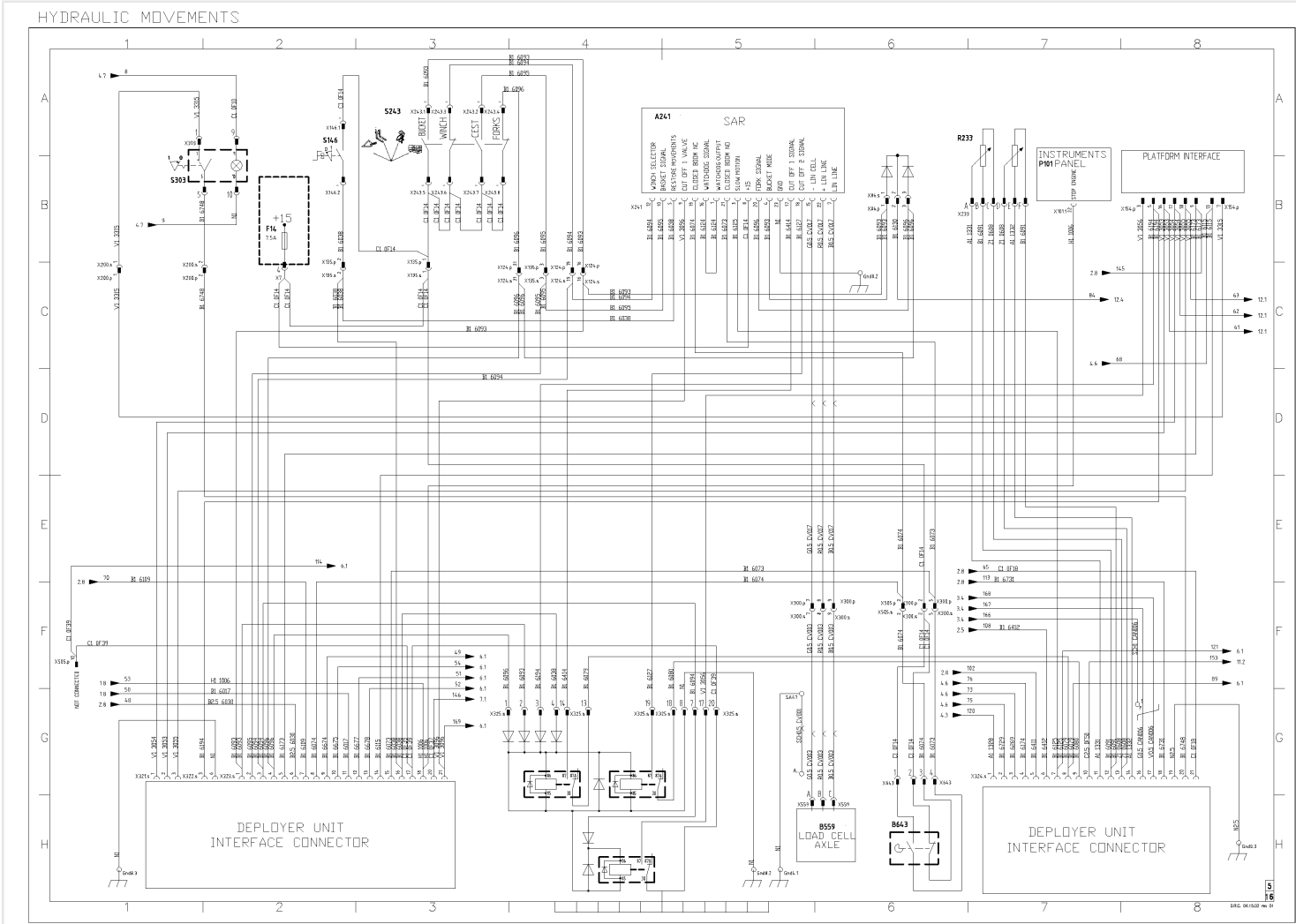

Figure: Wiring diagram - Hercules FPT - 20151006\_Page\_05





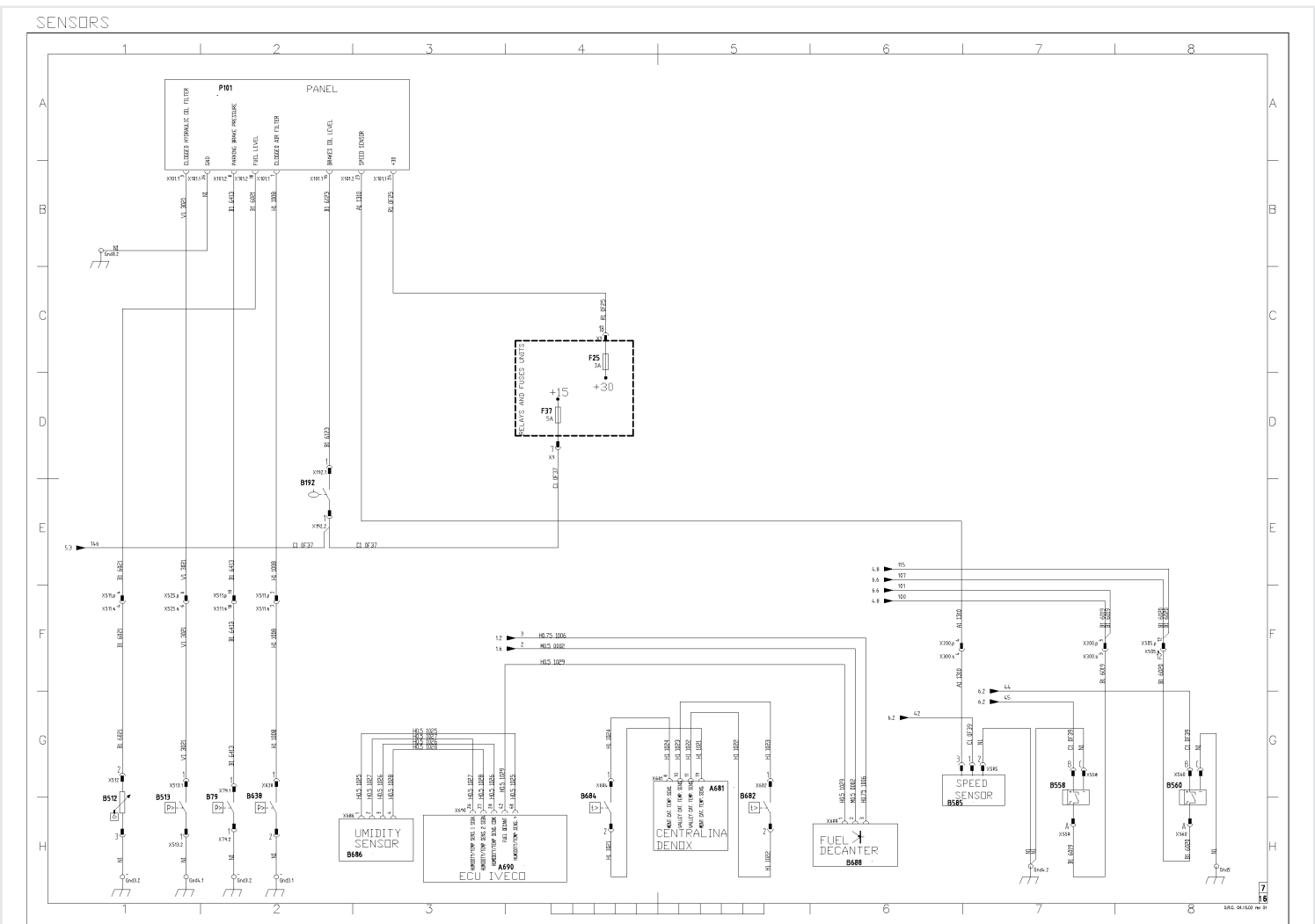
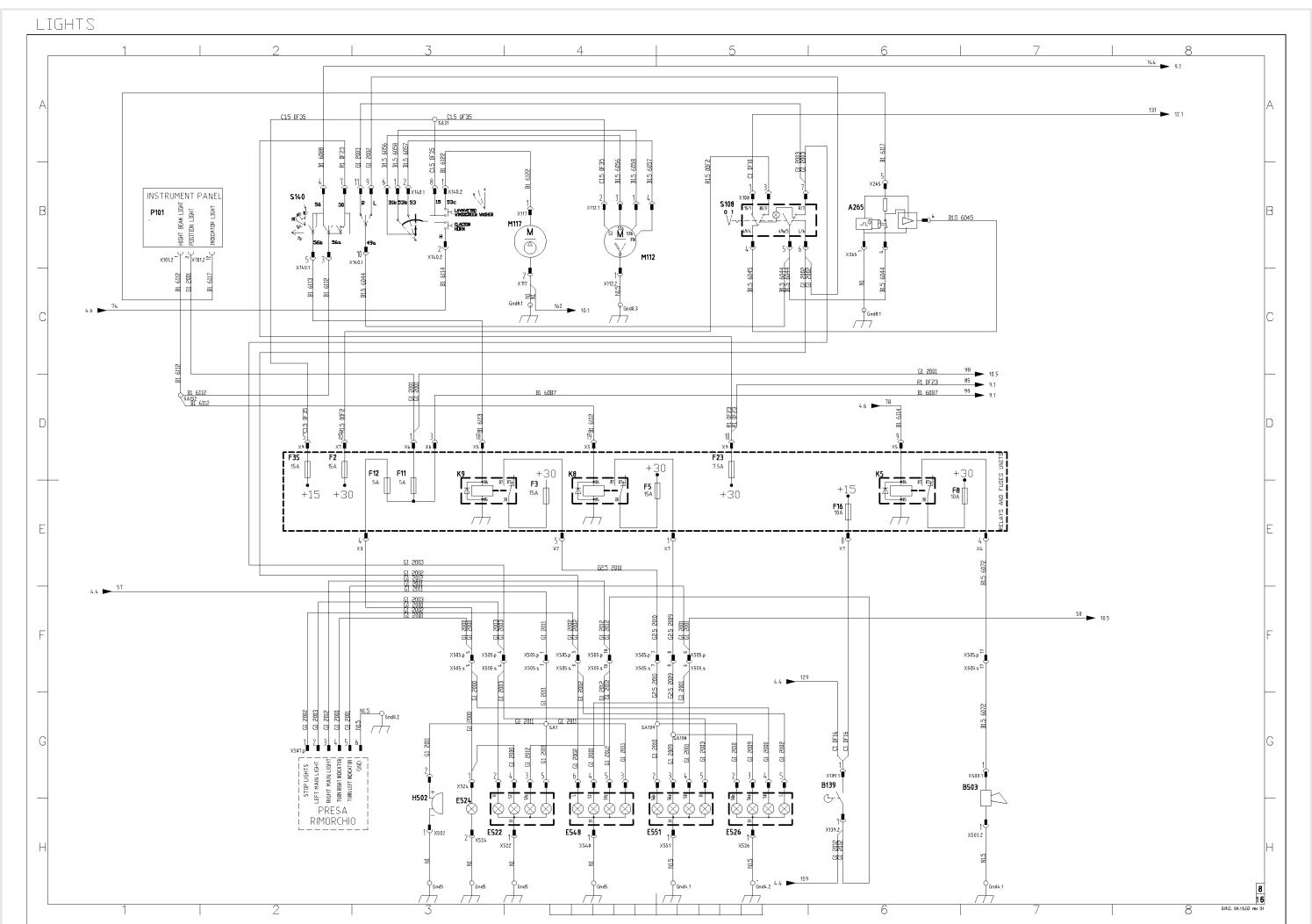

Figure: Wiring diagram - Hercules FPT - 20151006\_Page\_07





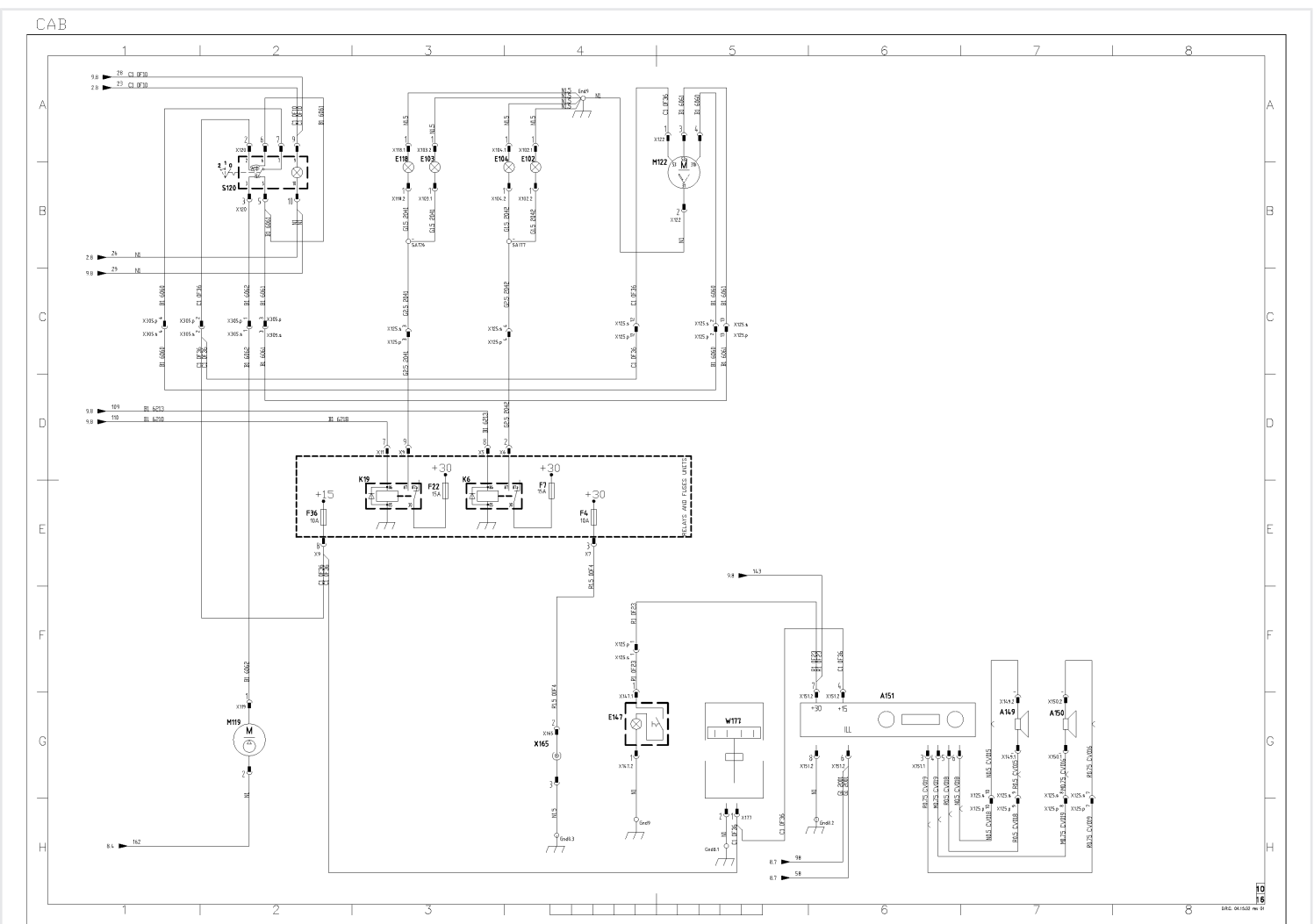

Figure: Wiring diagram - Hercules FPT - 20151006\_Page\_10

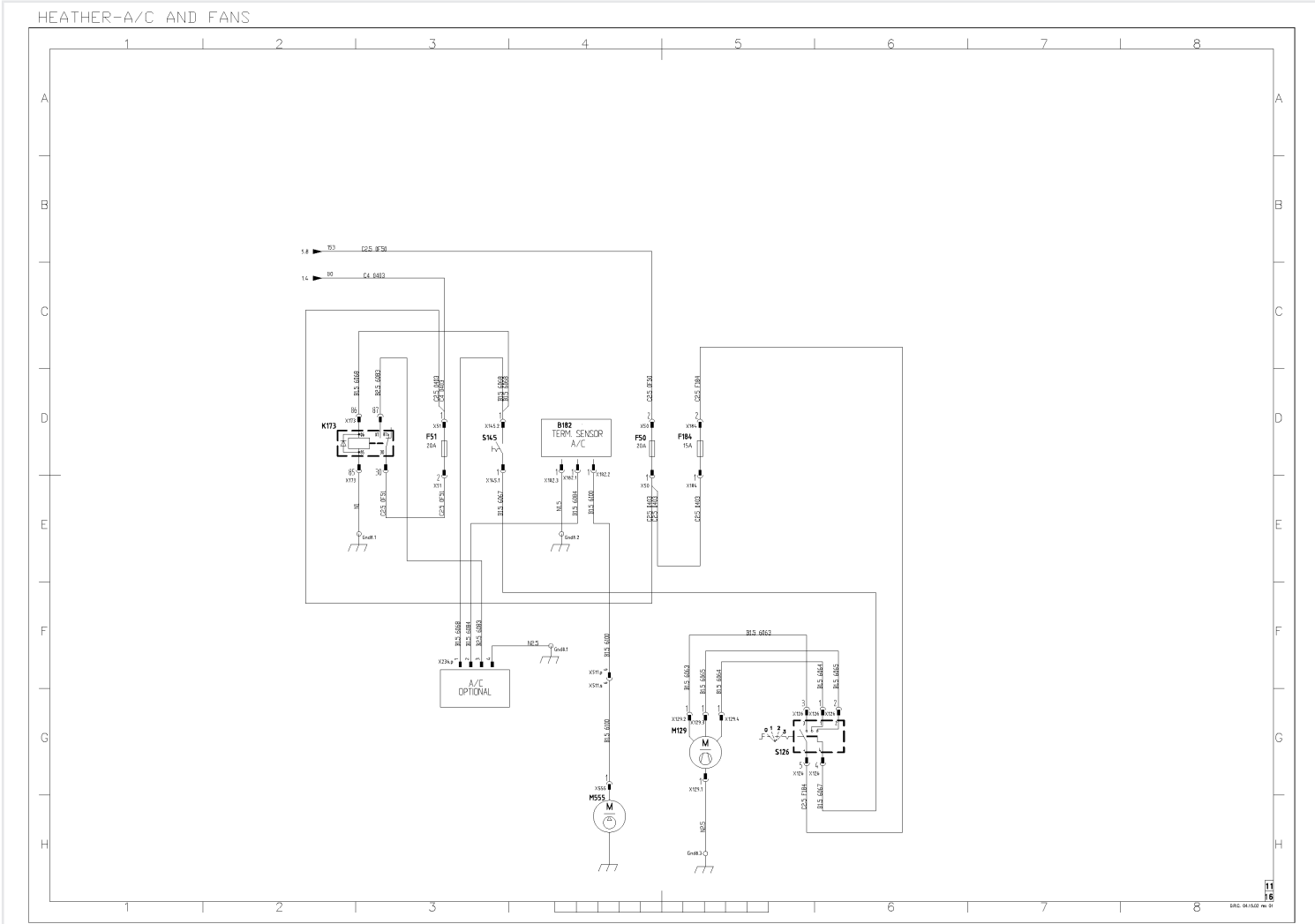
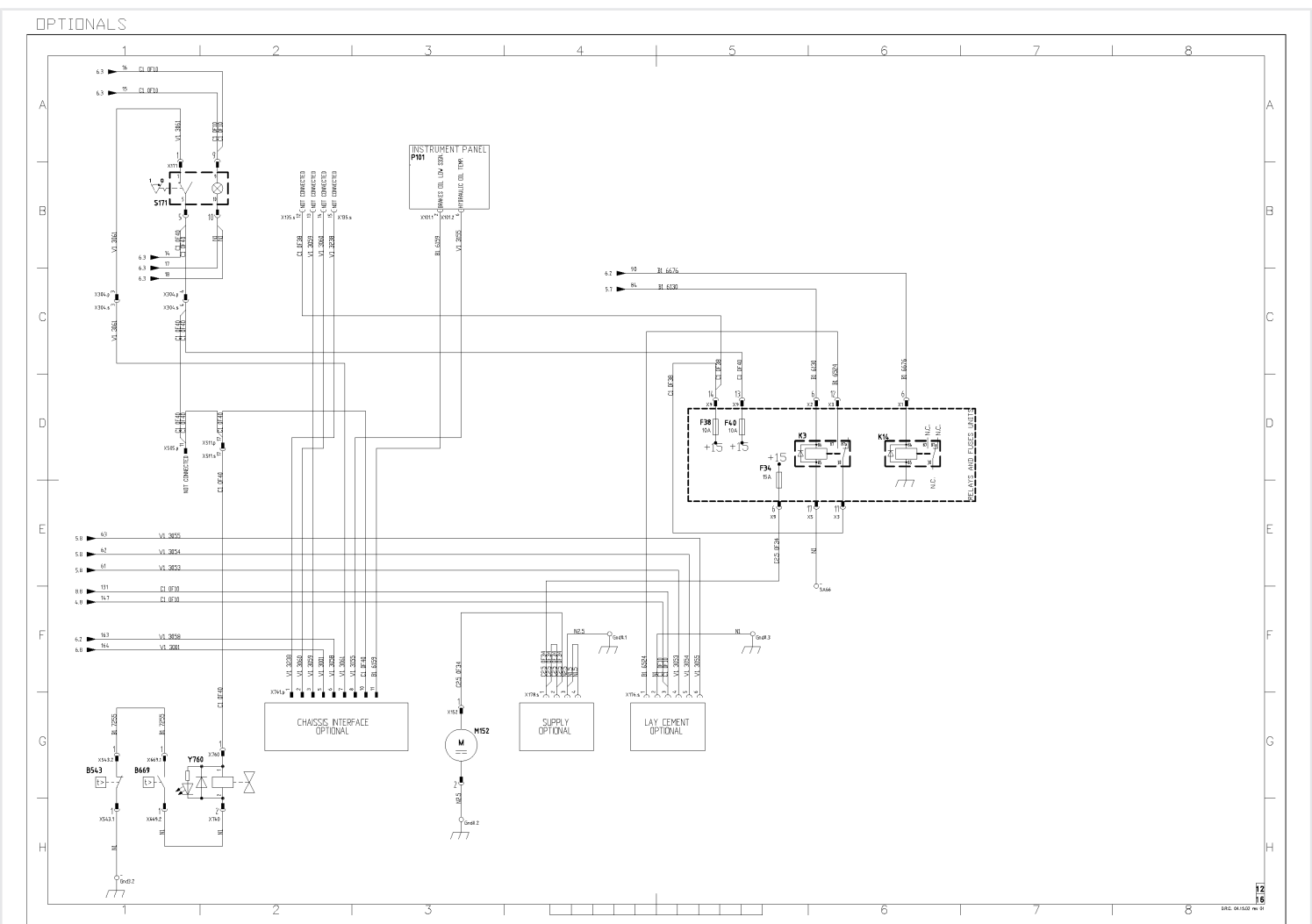

Figure: Wiring diagram - Hercules FPT - 20151006\_Page\_11





## 20.3 - Fuse box

The main circuit is protected by fuses placed in the general electronic board (fig. 150720-1).

To access the fuse box, remove the left plastic part aside the instrument panel by unscrewing the related screws (Fig 150720-2).

In case of electrical malfunction it is necessary to check the fuses as a first troubleshooting step.

**WARNING! Before accessing the fuse box in the cab, set the vehicle in the maintenance position.**

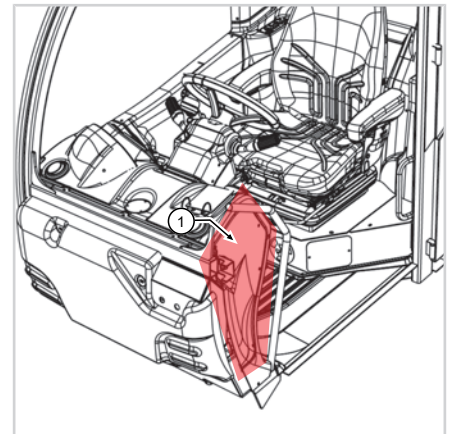

150720-2

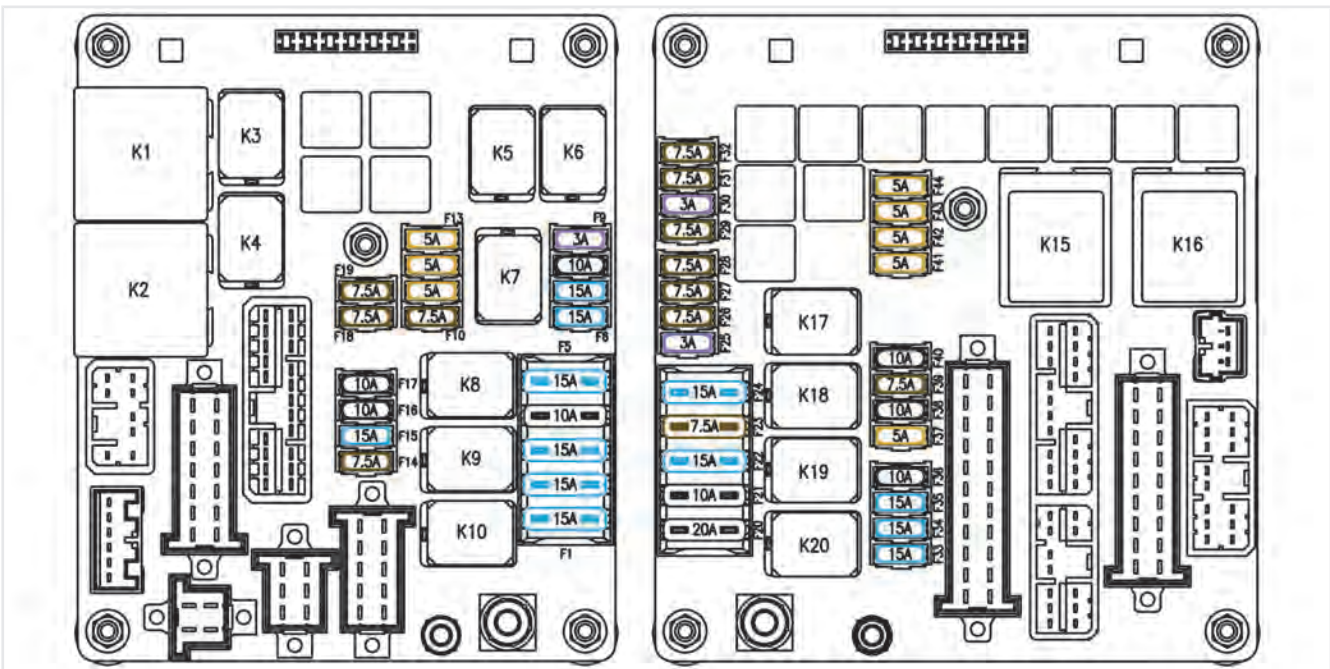
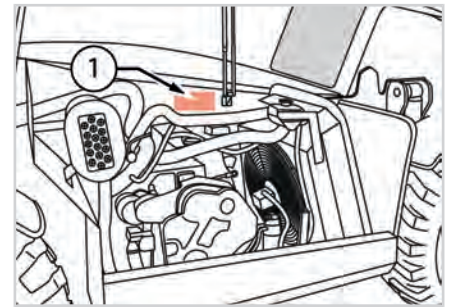

Figure: 150720-1

## 20.4 - Engine compartment fuses

The electrical circuits of the engine and attached components are protected by a fuse box placed in the engine compartment (fig. 150371-1). Remove the cover of the box to access the fuses. In case of electrical malfunction it is necessary to check the fuses as a first troubleshooting step.

**WARNING! Before accessing the engine control unit set the vehicle in the maintenance position.**



150737-1

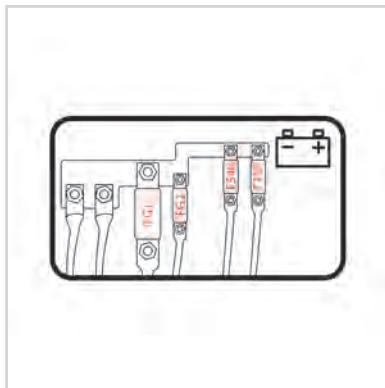

150737-2

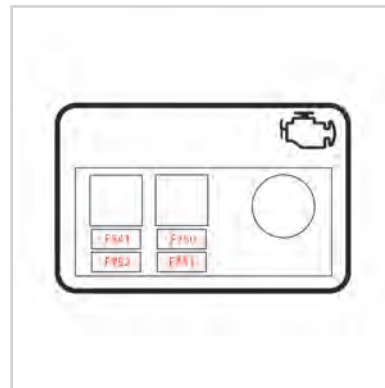

150737-3

## 21.1 - Components legend

1	Tank
2	Hydrostatic transmission pump
3	Hydrostatic transmission motor
4	Piston pump for movements
5	Gear pump for steering wheel and brakes
6	Negative brake cylinder
7	Gearbox cylinder
8	Gear change and negative brake solenoid valve
9	Pressure cut-off solenoid valve
10	Inching valve
11	Leveling
12	Accumulators recharge valve
13	Heat exchanger
14	Return hydraulic filter
15	Brake valve
16	Power steering
17	Front axle
18	Steering change solenoid valve
19	Rear axle
20	Distributor
21	Lifting
22	Compensation
23	Tilting
24	Extension
25	Quick couplings
26	Joystick

## 21.2 - Hydraulic diagram

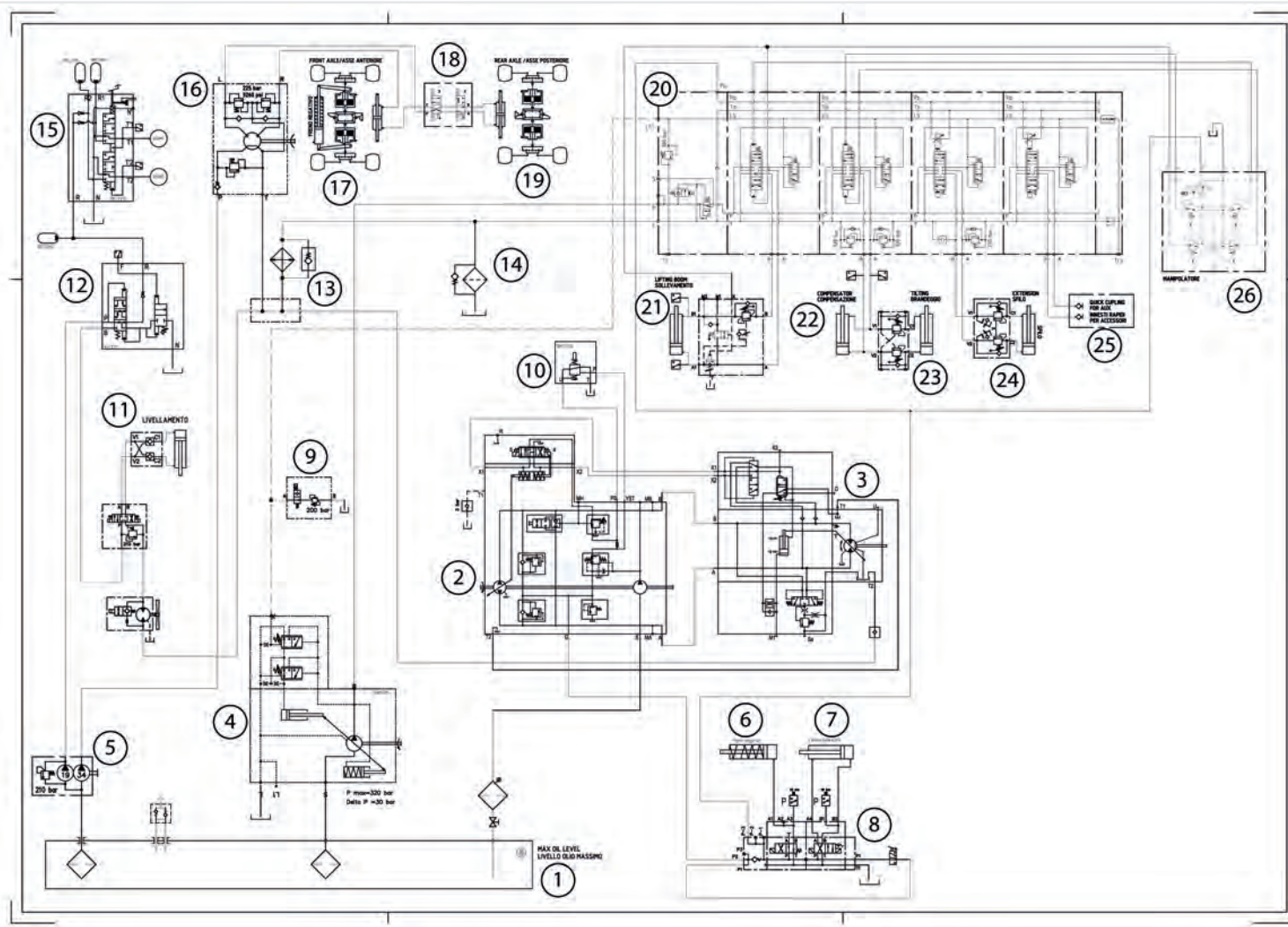
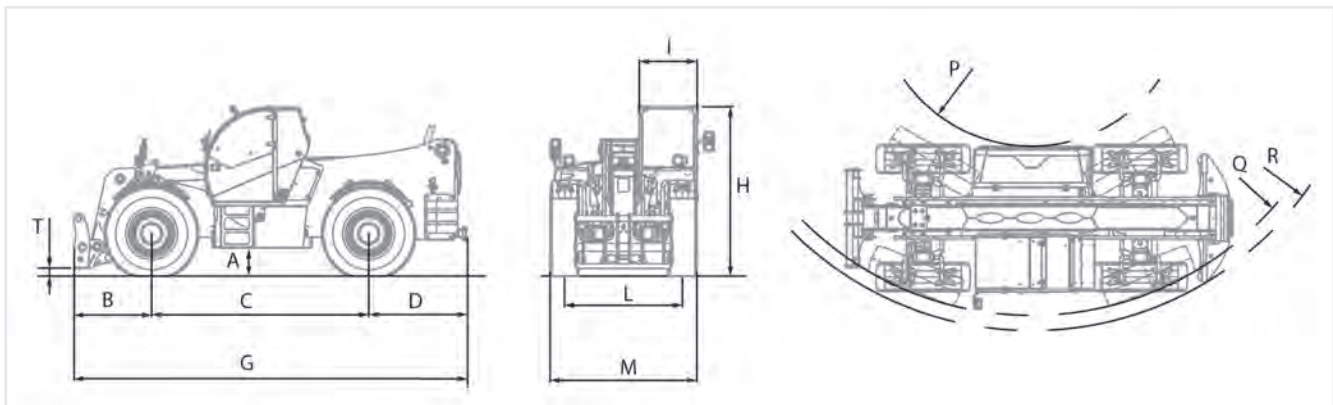

Figure: Hydraulic diagram - Hercules FPT - OB10-08-A90

## 22.1 - Hercules 120.10



	MFS3203
Vehicle model	HERCULES 120.10
Sector	CONSTRUCTION
Homologation	XLC203
Technical type	203
Version	Operating
A	490 mm (19,3 in)
B	1270 mm (50 in)
C	3300 mm (129,9 in)
D	1480 mm (58,3 in)
F	5460 mm (215 in)
G	6050 mm (238,2 in)
H	2890 mm (113,8 in)
I	980 mm (38,6 in)
L	1975 mm (77,8 in)
M	2420 mm (95,3 in)
P	1480 mm (58,3 in)
Q	4350 mm (171,3 in)
R	4580 mm (180,3 in)
T	134 mm (5,3 in)
U	2420 mm (95,3 in)
Z	2245 mm (88,4 in)
Maximum capacity	12000 kg (26455 lb)
Capacity at maximum height on wheels	7000 kg (15432 lb)
Capacity at maximum horizontal extension on wheels	3000 kg (6614 lb)
Maximum lifting height on wheels	9,50 m (31,2 ft)
Maximum horizontal extension on wheels	5,1 m (16,7 ft)
Fork swiveling angle	144°
Maximum climb angle	36%
Pull-out force	9700 daN (21806 lbf)
Towing force	11000 daN (24729 lbf)
Lifting	19,0 s



	MFS3203
Descent	15,2 s
Extension	13,2 s
Retraction	8,3 s
Forward swiveling	5,3 s
Reverse swiveling	4,0 s
Boom type	Telescopic with 1 telescopic section, counter-lever swing articulation (144°)
Wheels maximum capacity	12000 kg (26455 lb)
Maximum mass	17640 kg (38890 lb)
Unladen weight	16800 kg (37038 lb)
Maximum permitted mass on front axle	8500 kg (18739 lb)
Maximum permitted mass on rear axle	11500 kg (25353 lb)
Brand	FPT
Model	NEF-4 CR
Fueling	Diesel
Displacement	4485 cm <sup>3</sup> (274 in <sup>3</sup> )
Operation	4-stroke
Cooling system	Liquid
Nominal power	104 kW (139 HP)
@rpm	2200 rpm
Peak power	107 kW (143 HP)
@rpm	2000 rpm
Maximum torque	608 Nm (448 lbft)
@rpm	1600 rpm
Number and arrangement of cylinders	4, Vertical in line
Injection	Electronic, Common Rail
Consumption	211 g/kWh (347,1 lb/Hp h)
@rpm	2000 rpm
Intake	Turbo compressor 16 valve
Air Filter	Air pre-heating and air self-cleaning pre-filter
Emission standard	Stage IIIA/Tier 3
CO emissions	1,68 g/kWh (2,76 lb/Hp h)
HC emissions	0,09 g/kWh (0,15 lb/Hp h)
NOx emissions	3,27 g/kWh (5,38 lb/Hp h)
Particulate emissions	0,19 g/kWh (0,31 lb/Hp h)
Alternator	120 A
Battery	12 V - 185Ah - 1200 A cold cranking
Starter motor	12 V - 3 kW
Hydraulic pump type	"Load Sensing" variable flow pump for boom movements. Gear pump for power steering drive and for the cooling fan
Hydraulic pump capacity	160 L/min (42,3 gal/min)
Max. operating pressure	30,0 MPa (4351 psi)
Distributor type	"Flow Sharing" servo controlled hydraulic

	MFS3203
Distributor control	4in1 proportional Joystick
Boom hydraulic sockets	With Flat Face quick couplings
Transmission type	Hydrostatic with variable flow pump
Hydraulic motor	Hydrostatic with continuous automatic adjustment
Reversal	Electro-Hydraulic
Transmission gearbox	Servocontrolled 2-speed
Inching	With hydraulic pedal for controlled forward movement
Type of axles	2 steering, with 4 planetary reduction gears
Driving axles	Front and rear
Service braking	Oil bath with servo brake on front and rear axle with double hydraulic system
Parking braking	Negative actuation with electrical control
Front axle	With transverse leveling (8° + 8°) with control in the cab and 45% self-locking differential
Rear axle	Swinging
Type of steering	4 wheels / transversal / 2 wheels
Engine oil quantity	14,40 L (3,8 gal)
Engine oil specifications	DIECI ENGINE HP SAE 15W-40; (< -20°C / < -4°F) DIECI ENGINE EVOLUTION TIR4 SAE 10W-30
Front axle oil quantity	9,00 L (2,38 gal)
Front reduction gears oil quantity	1,25 L (0,33 gal)
Front axle oil specifications	DIECI GEAR EP/E LS 85W-90 API GL-5, MIL-L-2105D; (< -20°C / < -4°F) DIECI SPECIAL LS SYNT AXEL OIL 75W-90
Rear axle oil quantity	9,00 L (2,38 gal)
Rear reduction gears oil quantity	1,25 L (0,33 gal)
Rear axle oil specifications	DIECI GEAR EP/E LS 85W-90 API GL-5, MIL-L-2105D; (< -20°C / < -4°F) DIECI SPECIAL LS SYNT AXEL OIL 75W-90
Transmission gearbox oil quantity	2,50 L (0,66 gal)
Coolant quantity	14,00 L (3,7 gal)
Coolant specifications	Antifreeze Red
Grease quantity	4,00 kg (9 lb)
Grease specifications	NLGI - 1
Hydraulic system (total)	246,0 L (64,99 gal)
Hydraulic oil type	DIECI Hydro Telehandler Fluid ISO46
Air conditioning refrigerant quantity	1,10 kg (2 lb)
Air conditioning refrigerant specifications	R134A
Fuel tank	207,0 L (54,68 gal)
Acoustic pressure: Reference standard for stopped and running vehicle	Directive 2009/63/EC
Acoustic pressure: Reference standard perceived by the operator	UNI EN 12053:2008
Acoustic power: Reference standard	Directive 2000/14/EC
Acoustic power: Measured value	106 dB(A)
Acoustic power: Guaranteed value	107 dB(A)
Reference standard for seat vibrations	UNI EN 13059

	MFS3203
Value for seat vibrations	2,00 m/s <sup>2</sup> (6,6 ft/s <sup>2</sup> )
Uncertainty for seat vibrations value	1,00 m/s <sup>2</sup> (3,3 ft/s <sup>2</sup> )
Reference standard for steering wheel vibrations	EN 1032
Value for steering wheel vibrations	1,40 m/s <sup>2</sup> (4,6 ft/s <sup>2</sup> )
Uncertainty for steering wheel vibrations value	0,40 m/s <sup>2</sup> (1,3 ft/s <sup>2</sup> )
Load per wheel	16000 daN (35969 lbf)
Standard tires	17.5x25"
Optional tires	17.5R25"
Acoustic pressure: Value perceived by the operator with closed cab	69,5 dB(A)

Diagrams

Diagrams code	Vehicle code	Vehicle model	Production equipment code	Price list equipment code	Unit of measure	Operating Mode
AXB1537	MFR3202	Hercules 100.10	BUD1093	-	Metric	Wheels - 0°

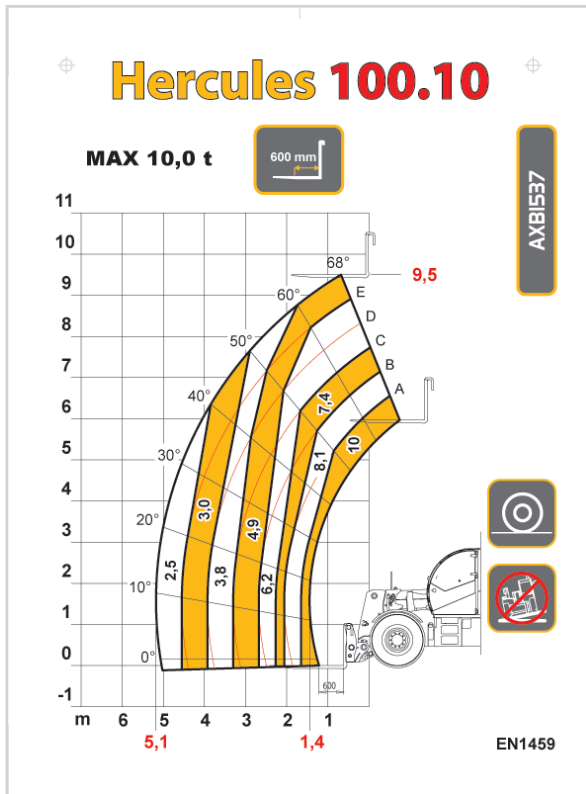

**22.1.1 - Equipment**

	Production code	Description
TCV0019	BCV8286	Fork extender/translator complete with forks 200 x 70 L = 1200 mm. Capacity 12.0 t (COG 0.6 m). Fork width from 600 to 1900 mm.
TCV0020	BCV8287	Fork extender/translator complete with forks 200 x 70 L = 1800 mm. Capacity 12.0 t (COG 0.6 m). Fork width from 600 to 1900 mm.
TCV0021	BCV8288	Fork extender/translator complete with forks 200 x 80 L = 2400 mm. Capacity 11.0 t (COG 0.6 m). Fork width from 600 to 1900 mm.
TFR0021	BUD1093, BUD1271	Pair of floating forks mm 200 x 70 L = 1200. Capacity 12.0 t (COG 0.6 m).
TFR0022	BUD1085	Pair of floating forks mm 200 x 70 L = 1800. Capacity 12.0 t (COG 0.6 m).
TFR0023	BUD1091	Pair of floating forks mm 200 x 80 L = 2400. Capacity 12.0 t (COG 0.6 m).
TGN0064	BUD4074	Gripper for pipe with pipe locker diameter up to 900 mm. Forks L = 1900 mm. Capacity 6.0 t (COG 0.9 m) (It is mandatory to choose the pre-arrangement).
TGN0067	BUD7012	Centring Handler. Capacity 4.0 t (It is mandatory to choose the pre-arrangement).
TBN0091	BUB2526, BUB2793	Excavating bucket without teeth, m <sup>3</sup> 3.00 SAE heap (width 2.50 m) (The bucket with blade protector is recommended)
TBN0092	BUB2526-S, BUB2793-S	Excavating bucket without teeth, m <sup>3</sup> 3.00 SAE heaped, (width 2.50 m) with BLADE PROTECTOR
TBN0093	BUB2640, BUB2794	Excavating bucket WITH teeth, m <sup>3</sup> 3.00 SAE heaped, (width 2.50 m).
TBN0094	BUB2529	Bucket for light material (spec. weight max 0.8 t/m <sup>3</sup> ) capacity 4.50 m <sup>3</sup> full SAE (width 3.00 m) (The bucket with blade protector is recommended).
TBN0095	BUB2529-S	Bucket for light material (spec. weight max 0.8 t/m <sup>3</sup> ) from 4.50 m <sup>3</sup> full SAE (width 3.00 m) WITH BLADE PROTECTOR.
TCS0066	BUD6494	Front man basket cm 215 x 120. Capacity 1000 kg incl. 3 people. (Pre-arrangement for man basket is compulsory)
TCS0071	BUD6495	Front man basket cm 215 x 120. Capacity 1000 kg incl. 3 people. For vehicle with remote control (Pre-arrangement for man basket is compulsory)
TCS0067	BUD6352	Material basket 200 x 120 x 130 cm with side door. Capacity 1500 kg
TSL0064	BUD4439	Crane extension L = 2.7 m with hook (4.0 t capacity) (Lifting equipment pre-arrangement is compulsory)
TSL0066	BUD4470	Winch for fork carriage (8.0 t capacity) with double tow rope guide (Pre-arrangement with lifting equipment is compulsory)
TSL0067	BUB2516	Hook for fork carriage with the same capacity as the vehicle

## 22.2 - Hercules 100.10

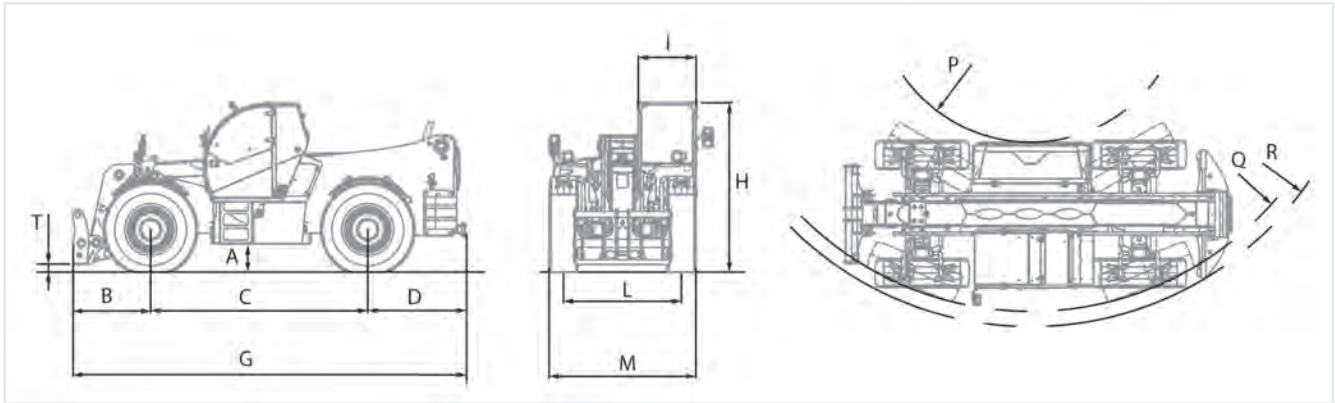

	MFR3202
Vehicle model	HERCULES 100.10
Sector	CONSTRUCTION
Homologation	XLC203
Technical type	203
Version	Operating
A	490 mm (19,3 in)
B	1270 mm (50 in)
C	3300 mm (129,9 in)
D	1480 mm (58,3 in)
F	5460 mm (215 in)
G	6050 mm (238,2 in)
H	2890 mm (113,8 in)
I	980 mm (38,6 in)
L	1975 mm (77,8 in)
M	2420 mm (95,3 in)
P	1480 mm (58,3 in)
Q	4350 mm (171,3 in)
R	4580 mm (180,3 in)
T	134 mm (5,3 in)
U	2420 mm (95,3 in)
Z	2245 mm (88,4 in)
Maximum capacity	10000 kg (22046 lb)
Capacity at maximum height on wheels	4900 kg (10803 lb)
Capacity at maximum horizontal extension on wheels	2500 kg (5512 lb)
Maximum lifting height on wheels	9,50 m (31,2 ft)
Maximum horizontal extension on wheels	5,15 m (16,9 ft)
Fork swiveling angle	144°
Maximum climb angle	36%
Pull-out force	9700 daN (21806 lbf)
Towing force	11000 daN (24729 lbf)
Lifting	16,5 s



	MFR3202
Descent	13,2 s
Extension	13,2 s
Retraction	8,3 s
Forward swiveling	5,3 s
Reverse swiveling	4,0 s
Boom type	Telescopic with 1 telescopic section, counter-lever swing articulation (144°)
Wheels maximum capacity	10000 kg (22046 lb)
Maximum mass	16900 kg (37258 lb)
Unladen weight	16000 kg (35274 lb)
Maximum permitted mass on front axle	7050 kg (15543 lb)
Maximum permitted mass on rear axle	10200 kg (22487 lb)
Brand	FPT
Model	NEF-4 CR
Fueling	Diesel
Displacement	4485 cm <sup>3</sup> (274 in <sup>3</sup> )
Operation	4-stroke
Cooling system	Liquid
Nominal power	104 kW (139 HP)
@rpm	2200 rpm
Peak power	107 kW (143 HP)
@rpm	2000 rpm
Maximum torque	608 Nm (448 lbft)
@rpm	1600 rpm
Number and arrangement of cylinders	4, Vertical in line
Injection	Electronic, Common Rail
Consumption	211 g/kWh (347,1 lb/Hp h)
@rpm	2000 rpm
Intake	Turbo compressor 16 valve
Air Filter	Air pre-heating and air self-cleaning pre-filter
Emission standard	Stage IIIA/Tier 3
CO emissions	1,68 g/kWh (2,76 lb/Hp h)
HC emissions	0,09 g/kWh (0,15 lb/Hp h)
NOx emissions	3,27 g/kWh (5,38 lb/Hp h)
Particulate emissions	0,19 g/kWh (0,31 lb/Hp h)
Alternator	120 A
Battery	12 V - 185Ah - 1200 A cold cranking
Starter motor	12 V - 3 kW
Hydraulic pump type	"Load Sensing" variable flow pump for boom movements. Gear pump for power steering drive and for the cooling fan
Hydraulic pump capacity	160 L/min (42,3 gal/min)
Max. operating pressure	30,0 MPa (4351 psi)
Distributor type	"Flow Sharing" servo controlled hydraulic

	MFR3202
Distributor control	4in1 proportional Joystick
Boom hydraulic sockets	With Flat Face quick couplings
Hydraulic motor	Hydrostatic with continuous automatic adjustment
Reversal	Electro-Hydraulic
Transmission gearbox	Servocontrolled 2-speed
Inching	With hydraulic pedal for controlled forward movement
Transmission type	Hydrostatic with variable flow pump
Type of axles	2 steering, with 4 planetary reduction gears
Driving axles	Front and rear
Service braking	Oil bath with servo brake on front and rear axle with double hydraulic system
Parking braking	Negative actuation with electrical control
Front axle	With transverse leveling (8° + 8°) with control in the cab and 45% self-locking differential
Rear axle	Swinging
Type of steering	4 wheels / transversal / 2 wheels
Engine oil quantity	14,40 L (3,8 gal)
Engine oil specifications	DIECI ENGINE HP SAE 15W-40; (< -20°C / < -4°F) DIECI ENGINE EVOLUTION TIR4 SAE 10W-30
Front axle oil quantity	9,00 L (2,38 gal)
Front reduction gears oil quantity	1,25 L (0,33 gal)
Front axle oil specifications	DIECI GEAR EP/E LS 85W-90 API GL-5, MIL-L-2105D; (< -20°C / < -4°F) DIECI SPECIAL LS SYNT AXEL OIL 75W-90
Rear axle oil quantity	9,00 L (2,38 gal)
Rear reduction gears oil quantity	1,25 L (0,33 gal)
Rear axle oil specifications	DIECI GEAR EP/E LS 85W-90 API GL-5, MIL-L-2105D; (< -20°C / < -4°F) DIECI SPECIAL LS SYNT AXEL OIL 75W-90
Transmission gearbox oil quantity	2,50 L (0,66 gal)
Coolant quantity	14,00 L (3,7 gal)
Coolant specifications	Antifreeze Red
Grease quantity	4,00 kg (9 lb)
Grease specifications	NLGI - 1
Hydraulic system (total)	246,0 L (64,99 gal)
Hydraulic oil type	DIECI Hydro Telehandler Fluid ISO46
Air conditioning refrigerant quantity	1,10 kg (2 lb)
Air conditioning refrigerant specifications	R134A
Fuel tank	207,0 L (54,68 gal)
Acoustic pressure: Reference standard for stopped and running vehicle	Directive 2009/63/EC
Acoustic pressure: Reference standard perceived by the operator	UNI EN 12053:2008
Acoustic pressure: Value perceived by the operator with closed cab	69,5 dB(A)
Acoustic power: Reference standard	Directive 2000/14/EC
Acoustic power: Measured value	106 dB(A)

	MFR3202
Acoustic power: Guaranteed value	107 dB(A)
Reference standard for seat vibrations	UNI EN 13059
Value for seat vibrations	2,00 m/s <sup>2</sup> (6,6 ft/s <sup>2</sup> )
Uncertainty for seat vibrations value	1,00 m/s <sup>2</sup> (3,3 ft/s <sup>2</sup> )
Reference standard for steering wheel vibrations	EN 1032
Value for steering wheel vibrations	1,40 m/s <sup>2</sup> (4,6 ft/s <sup>2</sup> )
Uncertainty for steering wheel vibrations value	0,40 m/s <sup>2</sup> (1,3 ft/s <sup>2</sup> )
Load per wheel	16000 daN (35969 lbf)
Standard tires	17.5x25"
Optional tires	17.5R25"

Diagrams

Diagrams code	Vehicle code	Vehicle model	Production equipment code	Price list equipment code	Unit of measure	Center of gravity
DOCDI0000491	MFS3203	Hercules 120.10	BUD1085	-	Metric	900 mm
DOCDI0000492	MFS3203	Hercules 120.10	BUD1093	-	Metric	600 mm
DOCDI0000493	MFS3203	Hercules 120.10	BUD1091	-	Metric	1200 mm

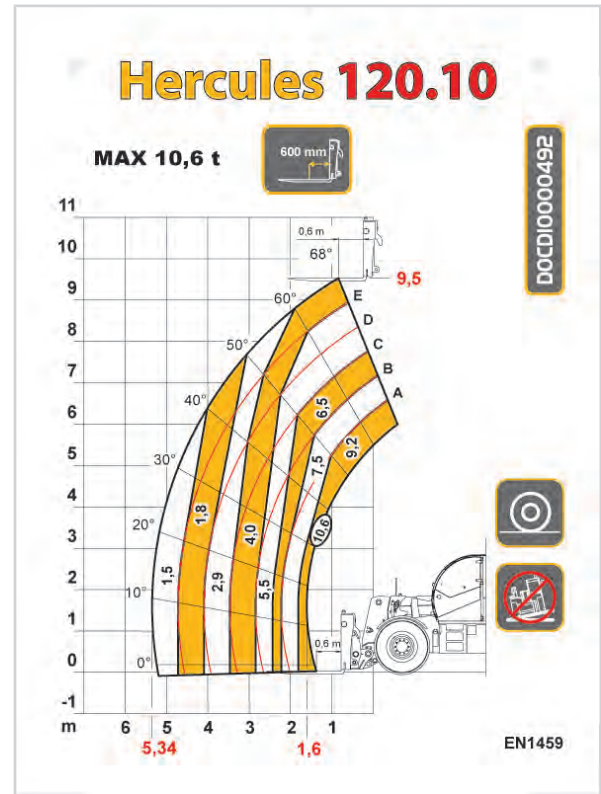
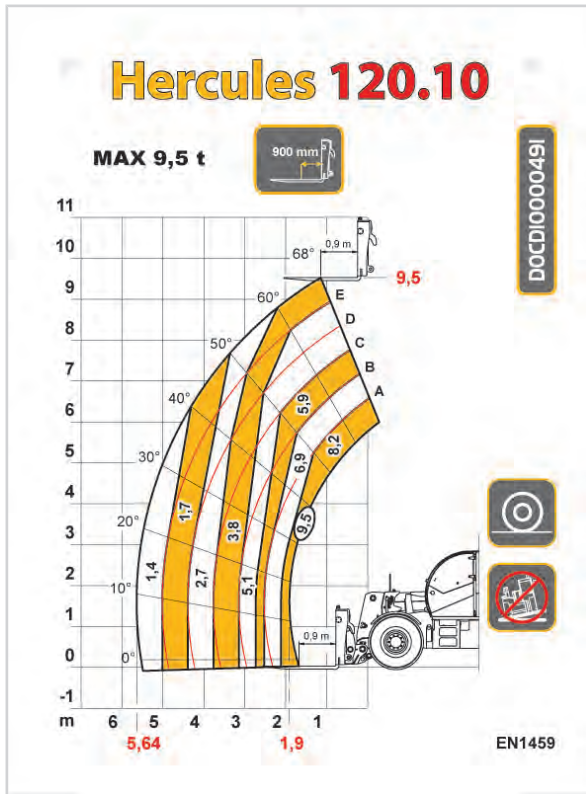

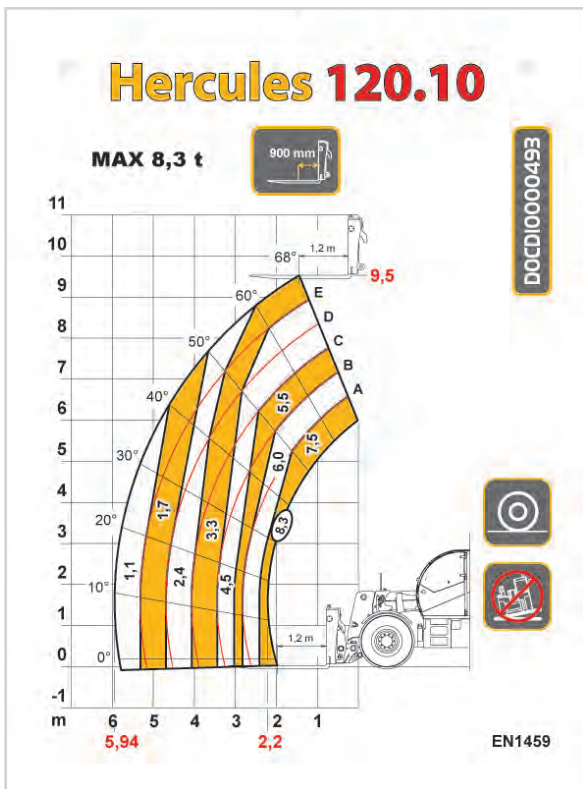

## 22.2.1 - Equipment

	Production code	Description
TCV0019	BCV8286	Fork extender/translator complete with forks 200 x 70 L = 1200 mm. Capacity 12.0 t (COG 0.6 m). Fork width from 600 to 1900 mm.
TCV0020	BCV8287	Fork extender/translator complete with forks 200 x 70 L = 1800 mm. Capacity 12.0 t (COG 0.6 m). Fork width from 600 to 1900 mm.
TCV0021	BCV8288	Fork extender/translator complete with forks 200 x 80 L = 2400 mm. Capacity 11.0 t (COG 0.6 m). Fork width from 600 to 1900 mm.
TFR0021	BUD1093, BUD1271	Pair of floating forks mm 200 x 70 L = 1200. Capacity 12.0 t (COG 0.6 m).
TFR0022	BUD1085	Pair of floating forks mm 200 x 70 L = 1800. Capacity 12.0 t (COG 0.6 m).
TFR0023	BUD1091	Pair of floating forks mm 200 x 80 L = 2400. Capacity 12.0 t (COG 0.6 m).
TGN0064	BUD4074	Gripper for pipe with pipe locker diameter up to 900 mm. Forks L = 1900 mm. Capacity 6.0 t (COG 0.9 m) (It is mandatory to choose the pre-arrangement).
TGN0066	BUD4098	Gripper for pipe with pipe locker diameter 900 mm. Forks L = 2400 mm. Capacity 5.0 t (COG 1.2 m) (It is mandatory to choose the pre-arrangement).
TGN0067	BUD7012	Centring Handler. Capacity 4.0 t (It is mandatory to choose the pre-arrangement).
TBN0091	BUB2526, BUB2793	Excavating bucket without teeth, m <sup>3</sup> 3.00 SAE heap (width 2.50 m) (The bucket with blade protector is recommended)
TBN0092	BUB2526-S, BUB2793-S	Excavating bucket without teeth, m <sup>3</sup> 3.00 SAE heaped, (width 2.50 m) with BLADE PROTECTOR
TBN0093	BUB2640, BUB2794	Excavating bucket WITH teeth, m <sup>3</sup> 3.00 SAE heaped, (width 2.50 m).
TBN0094	BUB2529	Bucket for light material (spec. weight max 0.8 t/m <sup>3</sup> ) capacity 4.50 m <sup>3</sup> full SAE (width 3.00 m) (The bucket with blade protector is recommended).
TBN0095	BUB2529-S	Bucket for light material (spec. weight max 0.8 t/m <sup>3</sup> ) from 4.50 m <sup>3</sup> full SAE (width 3.00 m) WITH BLADE PROTECTOR.
TCS0066	BUD6494	Front man basket cm 215 x 120. Capacity 1000 kg incl. 3 people. (Pre-arrangement for man basket is compulsory)
TCS0071	BUD6495	Front man basket cm 215 x 120. Capacity 1000 kg incl. 3 people. For vehicle with remote control (Pre-arrangement for man basket is compulsory)
TCS0067	BUD6352	Material basket 200 x 120 x 130 cm with side door. Capacity 1500 kg
TSL0064	BUD4439	Crane extension L = 2.7 m with hook (4.0 t capacity) (Lifting equipment pre-arrangement is compulsory)
TSL0066	BUD4470	Winch for fork carriage (8.0 t capacity) with double tow rope guide (Pre-arrangement with lifting equipment is compulsory)
TSL0067	BUB2516	Hook for fork carriage with the same capacity as the vehicle



## 22.3 - Environmental conditions

Although the vehicle and the equipment can be used in several different situations, however, it is necessary to observe, as a precautionary measure, compliance with minimum standards of operation as specified below:

Parameter	Allowed values
Operating temperatures	from -20°C to +40 °C (from -4 °F to 104 °F)
Average daily temperature	< +40 °C ( < 104 °F)
Storage temperature	from -25°C to +50 °C (from -13 °F to 122 °F)
Humidity	from 20 % to 95 %
Altitude	< 2500 m ( < 8200 ft)

Table 3: Environmental conditions table

## 22.4 - Electromagnetic Interference

In the case of additional equipment installed by the customer, the user must verify if the installation causes interference of any kind with the tools of the vehicle; if so, the user must correct such interferences.

It is essential to pay particular attention to mobile devices such as radio communications (telephones) that must be installed by trained service technicians must use externally mounted antennas.

In general, it should be kept in mind that any additional electrical equipment installed must comply with the regulations in the country of use of the vehicle.

## 22.5 - Radiations

The machine, in conditions of normal use, does not produce any type of radiation, ionizing and non ionizing, that can cause problems to the operator.

## 22.6 - DIECI Hydro Telehandler Fluid ISO46

The sticker shown aside (170350-1) indicates that the hydraulic circuit is filled with hydraulic oil DIECI Hydro Telehandler Fluid ISO46.



170350-1

### Specifications:

ISO 6743-4 HV, Afnor NFE 48-602, ISO 11158, DIN 51524 Part 3 HVLP, Afnor NFE 48-603 HV, ASTM D6158, Denison HF-0 / HF-1 / HF-2, Eaton Vickers I-286-S / M-2950-S, Cincinnati Vehicle P-68 / P-69 / P-70, Afnor NFE 48-690(dry), Afnor NFE 48-691(wet), U.S. Steel 126 / 127 / 136, JCMAS HK, Bosch variable vane pumps, Rexroth RE 90220, Sauer Danfoss 520L0463, General Motors (LS-2) LH-03-1 / LH-04-1 / LH-06-1, SEB 181222.

### Chemical-physical characteristics

Properties	Analysis method	Unit of measure	Value
Density at 15°C	ASTM D1298	kg/l	0.88
Viscosity at 40°C	ASTM D445	cSt	46.6
Viscosity at 100°C	ASTM D445	cSt	8.6
Viscosity Index	ASTM D2270	-	165
Kinematic viscosity at 40°C after Sonic Shear	ASTM D445	cSt	41.6
Viscosity Index after Sonic Shear	ASTM D2270	-	144
FZG Failure Load Stage	ASTM D5182	Stage	12
Flash Point (C.O.C.)	ASTM D92	°C	210
Pour point	ASTM D97	°C	-35
Temperature for Brookfield viscosity of 750cP	ASTM D2983	°C	-9

## 22.7 - DIECI Hydro Telehandler Fluid ISO32



### NOTE

**Hydraulic oil for cold climates is an optional.**

Consult your dealer in case of doubts or information on your vehicle.

The sticker shown aside (170351-1) indicates that the hydraulic circuit is filled with hydraulic oil DIECI Hydro Telehandler Fluid ISO32.



170351-1

### Specifications:

ISO 6743-4 HV, Afnor NFE 48-602, ISO 11158, DIN 51524 Part 3 HVL P, Afnor NFE 48-603 HV, ASTM D6158, Denison HF-0 / HF-1 / HF-2, Eaton Vickers I-286-S / M-2950-S, Cincinnati Vehicle P-68 / P-69 / P-70, Afnor NFE 48-690(dry), Afnor NFE 48-691(wet), U.S. Steel 126 / 127 / 136, JCMAS HK, Bosch variable vane pumps, Rexroth RE 90220, Sauer Danfoss 520L0463, General Motors (LS-2) LH-03-1 / LH-04-1 / LH-06-1, SEB 181222

### Chemical-physical characteristics:

Properties	Analysis method	Unit of measure	Value
Colour	-	-	Green-Blue
Density at 15°C	ASTM D1298	kg/l	0.878
Viscosity at 40°C	ASTM D445	cSt	32.4
Viscosity at 100°C	ASTM D445	cSt	6.6
Viscosity Index	ASTM D2270	-	165
Flash Point (C.O.C.)	ASTM D92	°C	205
Pour point	ASTM D97	°C	-37

## 22.8 - Declaration of conformity for F-Gas

In accordance with Art. 12 of EU Reg.No. 517/2014 concerning the fluorinated gases contained in the air-conditioning system, on the vehicles there are:

- Label indicating the amount of fluorinated gases present (Fig. 170501).
- Declaration of Conformity (a facsimile is shown below)

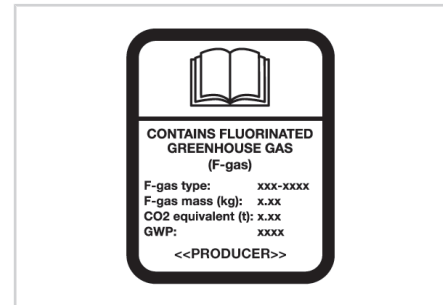

170501-1



### (Declaration of conformity with article 14 of Regulation (EU) No 517/2014 of the European Parliament and of the Council)

We Dieci s.r.l. (VAT number 01682740350), declare under our sole responsibility that when placing on the market pre-charged equipment, which we import to or manufacture in the Union, the hydrofluorocarbons contained in that equipment are accounted for within the quota system referred to in Chapter IV of Regulation (EU) No 517/2014 of the European Parliament and of the Council as:

*[please tick the relevant option(s): coverage by the quota system is achieved by one or more of the options below]*

- A. we hold authorisation(s) issued in accordance with Article 18(2) of Regulation (EU) No 517/2014 and registered in the registry referred to in Article 17 of that Regulation, at the time of release for free circulation to use the quota of a producer or importer of hydrofluorocarbons subject to Article 15 of Regulation (EU) No 517/2014 that cover(s) the quantity of hydrofluorocarbons contained in the equipment.
- B. *[for importers of equipment only]* the hydrofluorocarbons contained in the equipment have been placed on the market in the Union, subsequently exported and charged into the equipment outside the Union, and the undertaking that placed the hydrofluorocarbons on the market made a declaration stating that the quantity of hydrofluorocarbons has been or will be reported as placed on the market in the Union and that it has not been and will not be reported as direct supply for export in the meaning of Article 15(2)(c) of Regulation (EU) No 517/2014 pursuant to Article 19 of Regulation (EU) No 517/2014 and Section 5C of the Annex to Commission Implementing Regulation (EU) No 1191/2014.
- C. *[for equipment manufactured in the Union only]* the hydrofluorocarbons charged into the equipment were placed on the market by a producer or importer of hydrofluorocarbons subject to Article 15 of Regulation (EU) No 517/2014.

Signed for and on behalf of: Ennio Manghi, Director at DIECI S.r.l.

Montecchio Emilia, 31.01.2017

DIECI SRL  
Via E. Majorana, 2-4  
Montecchio Emilia (RE)  
One of the Directors  
Ennio Manghi

Dieci Srl  
Via E. Majorana, 2-4 • 42027 Montecchio Emilia • (Reggio Emilia) ITALY  
Tel. +39 0522 869611 • Fax +39 0522 869798 (Reception) • Fax +39 0522 869797 (Amis.re)  
www.dieci.com • E-mail: info@dieci.com  
Cap. Soc. Int. Vers. € 10.000.000,00 Reg. Imp. R.E. N. 01283560686 R.E.A. R.E. N. 204278 - C.F. 01283560686 • P.I. 01682740350



**22.9 - Forks technical data**

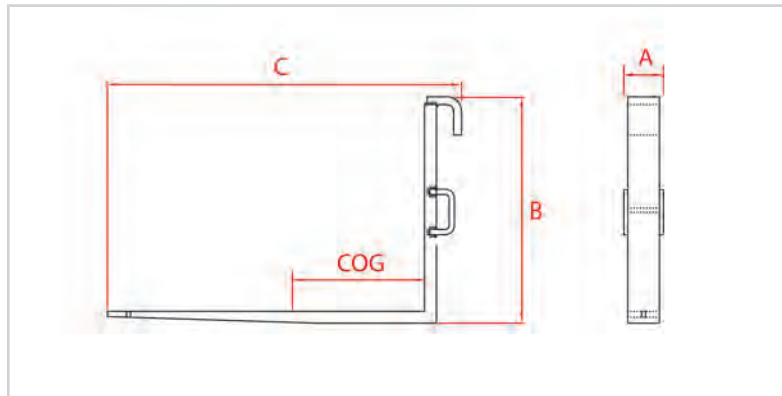

170221-1: Forks dimensions

**NOTE!** The dimensions indicated are for only one fork.

	<b>BUD1095</b>
Price list equipment code	-
Capacity	12000 kg (26455 lb)
Weight	391 kg (862 lb)
Width (A)	200 mm (7,9 in)
Height (B)	1100 mm (43,3 in)
Length (C)	2625 mm (103,3 in)
COG	600 mm (23,6 in)
Width section	200 mm (7,9 in)
Height section	70 mm (2,8 in)
	<b>BUD1091</b>
Price list equipment code	TFR0023
Capacity	16000 kg (35274 lb)
Weight	444 kg (979 lb)
Width (A)	200 mm (7,9 in)
Height (B)	1130 mm (44,5 in)
Length (C)	2645 mm (104,1 in)
COG	600 mm (23,6 in)
Width section	200 mm (7,9 in)
Height section	80 mm (3,1 in)
	<b>BUD1085</b>
Price list equipment code	TFR0022
Capacity	12000 kg (26455 lb)
Weight	320 kg (705 lb)
Width (A)	200 mm (7,9 in)
Height (B)	1100 mm (43,3 in)
Length (C)	2025 mm (79,7 in)
COG	600 mm (23,6 in)
Width section	200 mm (7,9 in)

	<b>BUD1085</b>
Height section	70 mm (2,8 in)
	<b>BUD1104</b>
Price list equipment code	TFR0024
Capacity	21000 kg (46297 lb)
Weight	440 kg (970 lb)
Width (A)	200 mm (7,9 in)
Height (B)	1160 mm (45,7 in)
Length (C)	2059 mm (81,1 in)
COG	900 mm (35,4 in)
Width section	200 mm (7,9 in)
Height section	95 mm (3,7 in)
	<b>BUD1105</b>
Price list equipment code	TFR0025
Capacity	21000 kg (46297 lb)
Weight	530 kg (1168 lb)
Width (A)	200 mm (7,9 in)
Height (B)	1160 mm (45,7 in)
Length (C)	2659 mm (104,7 in)
COG	900 mm (35,4 in)
Width section	200 mm (7,9 in)
Height section	95 mm (3,7 in)

**22.10 - Buckets technical data**

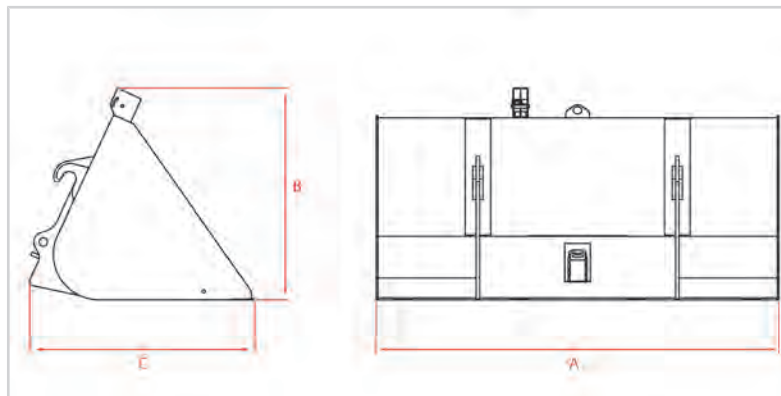

170220-1: Buckets dimensions

	<b>BUB2526</b>
Price list equipment code	TBN0091
SAE heap capacity	3 m <sup>3</sup> (106 ft <sup>3</sup> )
Struck capacity	-
Maximum density	-
Type of use	-
Weight	1355 kg (2987 lb)
Width (A)	3000 mm (118,1 in)
Height (B)	1451 mm (57,1 in)
Length (C)	1888 mm (74,3 in)
Tooth code	-
Number of teeth	-
	<b>BUB2529</b>
Price list equipment code	TBN0094
SAE heap capacity	4,5 m <sup>3</sup> (159 ft <sup>3</sup> )
Struck capacity	-
Maximum density	-
Type of use	-
Weight	1728 kg (3810 lb)
Width (A)	2500 mm (98,4 in)
Height (B)	1335 mm (52,6 in)
Length (C)	1713 mm (67,4 in)
Tooth code	-
Number of teeth	-



## 22.11 - Tires data



### ATTENTION

**Take precautions before operating on the tires pressure.**

Refer to the chapter Tyres [► 181].

		DOCDI0000851			
AID2624	Mitas	17.5-25	EM-20	188A2 171B	6,5 94
AID2625	Michelin	17,5 R25	Xmine D2	-	5,0 73
AID2658	Aeolus	20,5 R25	AL37	177B	6,5 94
AID2659	Michelin	20,5 R25	Xmine D2	-	5,5 80
AID2660	Michelin	605/80 R 25 (23.5 R25)	XLB	188E	7,0 102
AID2661	Good Year	23.5 R25	RL-4k	201A2	7,5 109
EID4925	Michelin	16.00 R25	XLB	177B	8,0 116
-	Camso	17,5 R25	-	188A2	7,0 102
-	Michelin	26,5 R25	-	195E	7,0 102
-	Good Year	18.00 R25	-	185B	7,5 109

### See also

Tyres [► 181]

The Control Log and Maintenance Log are to be considered as integral parts of the vehicle and equipment.

These logs must therefore accompany the vehicle and equipment for their life, to final disposal.

## 23.1 - Type of logs

### 23.1.1 - Control log

On the Control Log are recorded the main checks on the safety devices of the equipment, recommended by **Dieci S.r.l.**, with the related deadlines.

These checks ensure the proper operation of the safety devices.



#### NOTE

The checks specified in the Control Log are in addition to the routine maintenance described in the Maintenance Log.

### 23.1.2 - Maintenance Log

On the Maintenance Log are recorded all scheduled maintenance with timelines, referred to the use in normal, and not heavy, conditions. Such maintenance interventions allow to keep the machine or the equipment in the best efficiency conditions.

The scheduled maintenance intervals frequency must be reduced even to daily, if necessary, in particularly heavy working conditions (humidity, mud, sand, high dust level, etc ...).



#### NOTE

Consult the **DIECI** service center to establish appropriate timelines when working in particularly heavy environments.

## 23.2 - Instructions for compiling the logs

### 23.2.1 - Warnings on the control log

- The log must be prepared in accordance with the requirements imposed by the Essential Safety Requirement 4.4.2.b Annex I of the Machinery Directive 2006/42/EC, in order to preserve evidence of the proper conduct of all the inspection and maintenance activities concerning the machine safety.

- In the log, in addition to all the activities relating to the life, use and maintenance of safety systems of the machine (replacement of parts, overhauls, breakdowns, etc.) it is necessary to record all the checks required by the regulations in force in the country where the machine is used.
- It is also necessary that the name of the verifier technician and date of intervention are clearly identifiable.
- It is recommended to prepare, update and preserved with care, for the entire life of the machine or equipment, the control log.



#### NOTE

**Here following there are some pages to allow compiling such logs.**

Consult the Dieci s.r.l. service center to obtain more information regarding the availability of control and maintenance logs.

### 23.2.2 - Warnings on the maintenance log

- The maintenance log shall prevail for warranty claims. All activities relating to the life, use and maintenance of the vehicle must be registered in the log.

### 23.2.3 - Logs compiling

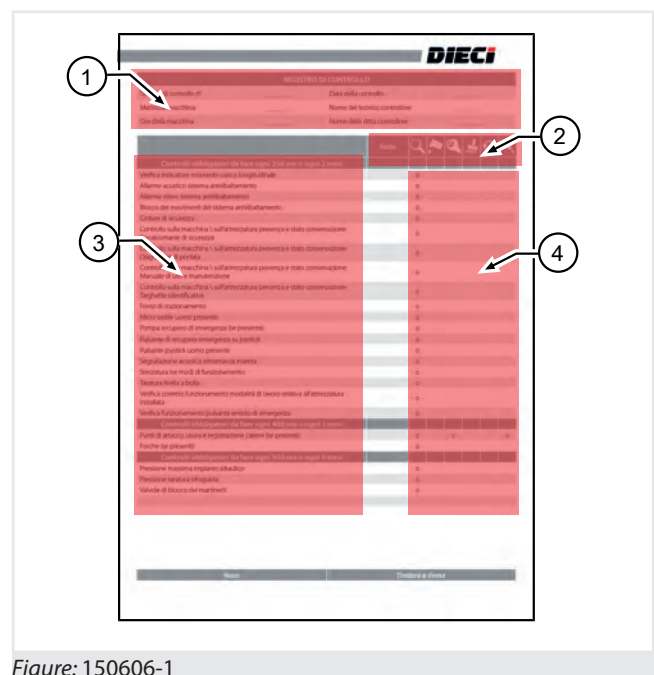

Figure: 150606-1

Each log (fig. 150606-1) requires the compilation of several parts:

- Log data

2. Operations to carry out
3. Component or device on which to carry out the operation to be performed
4. Space that indicates the obligatory operation marked by the symbol "o", and the possibility to annotate an extraordinary operation not included in the log.

### 23.2.4 - Logs legend

Symb ol	Description
	Control - Check
	Refilling
	Adjustment
	Cleaning
	Replacement
	Lubrication
	Intervention at an authorised service centre

## 23.2.5 - Intervals legend

**NOTE**

**The intervals are defined both in hours of work and in time intervals from the date of purchase.**

It is necessary to make interventions at the end of the first interval, either work hours or time.

Timelines	Description
0h	According to the need - To be completed in the case of checks not linked to deadlines but more or less related to the heavy operation of the vehicle
10h / 1m	Every 10 hours of operation or every month
50h / 1m	Every 50 hours of operation or every month
250h / 2m	Every 250 hours of operation or every 2 months
500h / 6m	Every 500 hours of operation or every 6 months
1000h / 1y	Every 1000 hours of operation or every year
2000h	Every 2000 hours of operation
4000h	Every 4000 hours of operation
2y	Every 2 years

### 23.3 - Periodic checks and recording mode (Italian only)

- The employer/operator of the machine is required to submit the machine to the periodic checks provided by law (Ministerial Decree 12/9/59 and Legislative Decree 81/08).
- He/she also has the obligation to comply with the maintenance and surveillance plan described in this Use and Maintenance Manual of the machine.
- The periodic inspection, testing and maintenance must be carried out by specialized personnel appointed for that purpose or by a workshop authorized by the manufacturer DIECI S.r.l.
- The employer/operator of the machine must record or appoint personnel trained for the purpose to record the results of the checks into the Control Log.
- Regular checks that have to be entered in the "Control log" are:
  - Quarterly periodic checks regarding the functionality and/or efficiency of ropes/chains according to Annex VI section 3.1.2 of Legislative Decree 81/08;
  - Yearly periodic checks regarding the operation and storage of the machine for safety purposes (yearly inspections, corrosion checks, calibration check, etc.) in accordance with Annex VII of Legislative Decree 81/08;
- The law provides administrative sanctions against those who do not carry out the quarterly and yearly checks.
- The Control Log, in which it is necessary to record the checks, must be shown on request to the officials responsible for monitoring the current legislation.
- Following the yearly periodic check the Local Health Authority official (Dip.SSIA), or the private Enabled Party chosen, issues a suitability report or prescribes the necessary obligations. The user is obliged to preserve the check report together with the Control Log.
- The checks evaluation must be recorded in the following dedicated pages indicating the outcome of the check, date, signature and any comments of the party in charge.
- If the pages dedicated in this Manual are insufficient for the annotations made in the life of the machine, use additional sheets being careful to compile them in the same way.







### 23.4 - Obligation and how to report to I.N.A.I.L. (National institute for insurance against accidents at work) (Italy only)

- The Legislative Decree 81/08 - Annex VII prescribes the obligation, to employers and users of lifting equipment with motor with capacity > 200 kg and lifting platforms for persons, to report the successful commissioning to the competent authority of the territory of the vehicle (currently I.N.A.I.L.), specifying the place of installation of the vehicle so that the authority itself may carry out the first verification.
- The report to I.N.A.I.L. must be carried out by attaching to the machine commissioning report a copy of the EC Declaration of Conformity of machinery referred to in Annex IIA of the Legislative Decree 17/2010 - Machinery Directive 2006/42/ EC.
- The original statements (CE Declaration of Conformity - Annex IIA) must be retained by the customer.
- The report to I.N.A.I.L. may be sent by registered letter with return receipt.

## 23.5 - Control log

The following are some sheets for filling in the Control Log.

CONTROL LOG			
Control sheet no.	.....	Control date	.....
Vehicle serial number:	.....	Controller technician name	.....
Vehicle hours	.....	Controller company name	.....

Controls								
250h / 3m	Longitudinal load momentum indicator check	<input type="checkbox"/>						
250h / 3m	Audible tipping alarm	<input type="checkbox"/>						
250h / 3m	Visual tipping warning	<input type="checkbox"/>						
250h / 3m	Anti-tipping system movements block	<input type="checkbox"/>						
250h / 3m	Seat belts	<input type="checkbox"/>						
250h / 3m	Control over the vehicle \ equipment for the presence and status of conservation of Safety Stickers	<input type="checkbox"/>						
250h / 3m	Control over the vehicle \ equipment for the presence and conservation status of Capacity Diagrams	<input type="checkbox"/>						
250h / 3m	Control over the vehicle \ equipment for the presence and conservation status of the Use and maintenance manual	<input type="checkbox"/>						
250h / 3m	Control over the vehicle \ equipment for the presence and conservation status of Identification labels	<input type="checkbox"/>						
250h / 3m	Parking brake	<input type="checkbox"/>						
250h / 3m	Deadman seat microswitch	<input type="checkbox"/>						
250h / 3m	Emergency recovery pump (if any)	<input type="checkbox"/>						
250h / 3m	Emergency recovery button on joystick	<input type="checkbox"/>						
250h / 3m	Deadman joystick button	<input type="checkbox"/>						
250h / 3m	Reverse gear engaged acoustic signal	<input type="checkbox"/>						
250h / 3m	Three operation mode steering	<input type="checkbox"/>						
250h / 3m	Spirit level indication	<input type="checkbox"/>						
250h / 2m	Installed equipment working mode correct operation check	<input type="checkbox"/>						
250h / 2m	Emergency stop button operation check	<input type="checkbox"/>						
250h / 2m	Operation check consistent with the instructions in the cab	<input type="checkbox"/>						
400h / 3m	Chains (if any) coupling points, wear and adjustment	<input type="checkbox"/>		<input type="checkbox"/>			<input type="checkbox"/>	
400h / 3m	Forks (if present)	<input type="checkbox"/>						
500h / 6m	Hydraulic system maximum pressure	<input type="checkbox"/>						
500h / 6m	Power steering calibration pressure	<input type="checkbox"/>						
500h / 6m	Jacks block valves	<input type="checkbox"/>						

Notes	Stamp and signature







CONTROL LOG			
Control sheet no.	.....	Control date	.....
Vehicle serial number:	.....	Controller technician name	.....
Vehicle hours	.....	Controller company name	.....

Controls								
250h / 3m	Longitudinal load momentum indicator check	O						
250h / 3m	Audible tipping alarm	O						
250h / 3m	Visual tipping warning	O						
250h / 3m	Anti-tipping system movements block	O						
250h / 3m	Seat belts	O						
250h / 3m	Control over the vehicle \ equipment for the presence and status of conservation of Safety Stickers	O						
250h / 3m	Control over the vehicle \ equipment for the presence and conservation status of Capacity Diagrams	O						
250h / 3m	Control over the vehicle \ equipment for the presence and conservation status of the Use and maintenance manual	O						
250h / 3m	Control over the vehicle \ equipment for the presence and conservation status of Identification labels	O						
250h / 3m	Parking brake	O						
250h / 3m	Deadman seat microswitch	O						
250h / 3m	Emergency recovery pump (if any)	O						
250h / 3m	Emergency recovery button on joystick	O						
250h / 3m	Deadman joystick button	O						
250h / 3m	Reverse gear engaged acoustic signal	O						
250h / 3m	Three operation mode steering	O						
250h / 3m	Spirit level indication	O						
250h / 2m	Installed equipment working mode correct operation check	O						
250h / 2m	Emergency stop button operation check	O						
250h / 2m	Operation check consistent with the instructions in the cab	O						
400h / 3m	Chains (if any) coupling points, wear and adjustment	O		O			O	
400h / 3m	Forks (if present)	O						
500h / 6m	Hydraulic system maximum pressure	O						
500h / 6m	Power steering calibration pressure	O						
500h / 6m	Jacks block valves	O						

Notes	Stamp and signature



CONTROL LOG			
Control sheet no.	.....	Control date	.....
Vehicle serial number:	.....	Controller technician name	.....
Vehicle hours	.....	Controller company name	.....

	Controls							
250h / 3m	Longitudinal load momentum indicator check	O						
250h / 3m	Audible tipping alarm	O						
250h / 3m	Visual tipping warning	O						
250h / 3m	Anti-tipping system movements block	O						
250h / 3m	Seat belts	O						
250h / 3m	Control over the vehicle \ equipment for the presence and status of conservation of Safety Stickers	O						
250h / 3m	Control over the vehicle \ equipment for the presence and conservation status of Capacity Diagrams	O						
250h / 3m	Control over the vehicle \ equipment for the presence and conservation status of the Use and maintenance manual	O						
250h / 3m	Control over the vehicle \ equipment for the presence and conservation status of Identification labels	O						
250h / 3m	Parking brake	O						
250h / 3m	Deadman seat microswitch	O						
250h / 3m	Emergency recovery pump (if any)	O						
250h / 3m	Emergency recovery button on joystick	O						
250h / 3m	Deadman joystick button	O						
250h / 3m	Reverse gear engaged acoustic signal	O						
250h / 3m	Three operation mode steering	O						
250h / 3m	Spirit level indication	O						
250h / 2m	Installed equipment working mode correct operation check	O						
250h / 2m	Emergency stop button operation check	O						
250h / 2m	Operation check consistent with the instructions in the cab	O						
400h / 3m	Chains (if any) coupling points, wear and adjustment	O		O			O	
400h / 3m	Forks (if present)	O						
500h / 6m	Hydraulic system maximum pressure	O						
500h / 6m	Power steering calibration pressure	O						
500h / 6m	Jacks block valves	O						







Notes	Stamp and signature

CONTROL LOG			
Control sheet no.	.....	Control date	.....
Vehicle serial number:	.....	Controller technician name	.....
Vehicle hours	.....	Controller company name	.....

Controls								
250h / 3m	Longitudinal load momentum indicator check	O						
250h / 3m	Audible tipping alarm	O						
250h / 3m	Visual tipping warning	O						
250h / 3m	Anti-tipping system movements block	O						
250h / 3m	Seat belts	O						
250h / 3m	Control over the vehicle \ equipment for the presence and status of conservation of Safety Stickers	O						
250h / 3m	Control over the vehicle \ equipment for the presence and conservation status of Capacity Diagrams	O						
250h / 3m	Control over the vehicle \ equipment for the presence and conservation status of the Use and maintenance manual	O						
250h / 3m	Control over the vehicle \ equipment for the presence and conservation status of Identification labels	O						
250h / 3m	Parking brake	O						
250h / 3m	Deadman seat microswitch	O						
250h / 3m	Emergency recovery pump (if any)	O						
250h / 3m	Emergency recovery button on joystick	O						
250h / 3m	Deadman joystick button	O						
250h / 3m	Reverse gear engaged acoustic signal	O						
250h / 3m	Three operation mode steering	O						
250h / 3m	Spirit level indication	O						
250h / 2m	Installed equipment working mode correct operation check	O						
250h / 2m	Emergency stop button operation check	O						
250h / 2m	Operation check consistent with the instructions in the cab	O						
400h / 3m	Chains (if any) coupling points, wear and adjustment	O		O			O	
400h / 3m	Forks (if present)	O						
500h / 6m	Hydraulic system maximum pressure	O						
500h / 6m	Power steering calibration pressure	O						
500h / 6m	Jacks block valves	O						

Notes	Stamp and signature

CONTROL LOG			
Control sheet no.	.....	Control date	.....
Vehicle serial number:	.....	Controller technician name	.....
Vehicle hours	.....	Controller company name	.....

	Controls							
250h / 3m	Longitudinal load momentum indicator check	O						
250h / 3m	Audible tipping alarm	O						
250h / 3m	Visual tipping warning	O						
250h / 3m	Anti-tipping system movements block	O						
250h / 3m	Seat belts	O						
250h / 3m	Control over the vehicle \ equipment for the presence and status of conservation of Safety Stickers	O						
250h / 3m	Control over the vehicle \ equipment for the presence and conservation status of Capacity Diagrams	O						
250h / 3m	Control over the vehicle \ equipment for the presence and conservation status of the Use and maintenance manual	O						
250h / 3m	Control over the vehicle \ equipment for the presence and conservation status of Identification labels	O						
250h / 3m	Parking brake	O						
250h / 3m	Deadman seat microswitch	O						
250h / 3m	Emergency recovery pump (if any)	O						
250h / 3m	Emergency recovery button on joystick	O						
250h / 3m	Deadman joystick button	O						
250h / 3m	Reverse gear engaged acoustic signal	O						
250h / 3m	Three operation mode steering	O						
250h / 3m	Spirit level indication	O						
250h / 2m	Installed equipment working mode correct operation check	O						
250h / 2m	Emergency stop button operation check	O						
250h / 2m	Operation check consistent with the instructions in the cab	O						
400h / 3m	Chains (if any) coupling points, wear and adjustment	O		O			O	
400h / 3m	Forks (if present)	O						
500h / 6m	Hydraulic system maximum pressure	O						
500h / 6m	Power steering calibration pressure	O						
500h / 6m	Jacks block valves	O						







Notes	Stamp and signature

CONTROL LOG			
Control sheet no.	.....	Control date	.....
Vehicle serial number:	.....	Controller technician name	.....
Vehicle hours	.....	Controller company name	.....

Controls								
250h / 3m	Longitudinal load momentum indicator check	O						
250h / 3m	Audible tipping alarm	O						
250h / 3m	Visual tipping warning	O						
250h / 3m	Anti-tipping system movements block	O						
250h / 3m	Seat belts	O						
250h / 3m	Control over the vehicle \ equipment for the presence and status of conservation of Safety Stickers	O						
250h / 3m	Control over the vehicle \ equipment for the presence and conservation status of Capacity Diagrams	O						
250h / 3m	Control over the vehicle \ equipment for the presence and conservation status of the Use and maintenance manual	O						
250h / 3m	Control over the vehicle \ equipment for the presence and conservation status of Identification labels	O						
250h / 3m	Parking brake	O						
250h / 3m	Deadman seat microswitch	O						
250h / 3m	Emergency recovery pump (if any)	O						
250h / 3m	Emergency recovery button on joystick	O						
250h / 3m	Deadman joystick button	O						
250h / 3m	Reverse gear engaged acoustic signal	O						
250h / 3m	Three operation mode steering	O						
250h / 3m	Spirit level indication	O						
250h / 2m	Installed equipment working mode correct operation check	O						
250h / 2m	Emergency stop button operation check	O						
250h / 2m	Operation check consistent with the instructions in the cab	O						
400h / 3m	Chains (if any) coupling points, wear and adjustment	O		O			O	
400h / 3m	Forks (if present)	O						
500h / 6m	Hydraulic system maximum pressure	O						
500h / 6m	Power steering calibration pressure	O						
500h / 6m	Jacks block valves	O						

Notes	Stamp and signature

CONTROL LOG			
Control sheet no.	.....	Control date	.....
Vehicle serial number:	.....	Controller technician name	.....
Vehicle hours	.....	Controller company name	.....

	Controls							
250h / 3m	Longitudinal load momentum indicator check	O						
250h / 3m	Audible tipping alarm	O						
250h / 3m	Visual tipping warning	O						
250h / 3m	Anti-tipping system movements block	O						
250h / 3m	Seat belts	O						
250h / 3m	Control over the vehicle \ equipment for the presence and status of conservation of Safety Stickers	O						
250h / 3m	Control over the vehicle \ equipment for the presence and conservation status of Capacity Diagrams	O						
250h / 3m	Control over the vehicle \ equipment for the presence and conservation status of the Use and maintenance manual	O						
250h / 3m	Control over the vehicle \ equipment for the presence and conservation status of Identification labels	O						
250h / 3m	Parking brake	O						
250h / 3m	Deadman seat microswitch	O						
250h / 3m	Emergency recovery pump (if any)	O						
250h / 3m	Emergency recovery button on joystick	O						
250h / 3m	Deadman joystick button	O						
250h / 3m	Reverse gear engaged acoustic signal	O						
250h / 3m	Three operation mode steering	O						
250h / 3m	Spirit level indication	O						
250h / 2m	Installed equipment working mode correct operation check	O						
250h / 2m	Emergency stop button operation check	O						
250h / 2m	Operation check consistent with the instructions in the cab	O						
400h / 3m	Chains (if any) coupling points, wear and adjustment	O		O			O	
400h / 3m	Forks (if present)	O						
500h / 6m	Hydraulic system maximum pressure	O						
500h / 6m	Power steering calibration pressure	O						
500h / 6m	Jacks block valves	O						







Notes	Stamp and signature

CONTROL LOG			
Control sheet no.	.....	Control date	.....
Vehicle serial number:	.....	Controller technician name	.....
Vehicle hours	.....	Controller company name	.....

	Controls							
250h / 3m	Longitudinal load momentum indicator check	O						
250h / 3m	Audible tipping alarm	O						
250h / 3m	Visual tipping warning	O						
250h / 3m	Anti-tipping system movements block	O						
250h / 3m	Seat belts	O						
250h / 3m	Control over the vehicle \ equipment for the presence and status of conservation of Safety Stickers	O						
250h / 3m	Control over the vehicle \ equipment for the presence and conservation status of Capacity Diagrams	O						
250h / 3m	Control over the vehicle \ equipment for the presence and conservation status of the Use and maintenance manual	O						
250h / 3m	Control over the vehicle \ equipment for the presence and conservation status of Identification labels	O						
250h / 3m	Parking brake	O						
250h / 3m	Deadman seat microswitch	O						
250h / 3m	Emergency recovery pump (if any)	O						
250h / 3m	Emergency recovery button on joystick	O						
250h / 3m	Deadman joystick button	O						
250h / 3m	Reverse gear engaged acoustic signal	O						
250h / 3m	Three operation mode steering	O						
250h / 3m	Spirit level indication	O						
250h / 2m	Installed equipment working mode correct operation check	O						
250h / 2m	Emergency stop button operation check	O						
250h / 2m	Operation check consistent with the instructions in the cab	O						
400h / 3m	Chains (if any) coupling points, wear and adjustment	O		O			O	
400h / 3m	Forks (if present)	O						
500h / 6m	Hydraulic system maximum pressure	O						
500h / 6m	Power steering calibration pressure	O						
500h / 6m	Jacks block valves	O						

Notes	Stamp and signature

CONTROL LOG			
Control sheet no.	.....	Control date	.....
Vehicle serial number:	.....	Controller technician name	.....
Vehicle hours	.....	Controller company name	.....

	Controls							
250h / 3m	Longitudinal load momentum indicator check	O						
250h / 3m	Audible tipping alarm	O						
250h / 3m	Visual tipping warning	O						
250h / 3m	Anti-tipping system movements block	O						
250h / 3m	Seat belts	O						
250h / 3m	Control over the vehicle \ equipment for the presence and status of conservation of Safety Stickers	O						
250h / 3m	Control over the vehicle \ equipment for the presence and conservation status of Capacity Diagrams	O						
250h / 3m	Control over the vehicle \ equipment for the presence and conservation status of the Use and maintenance manual	O						
250h / 3m	Control over the vehicle \ equipment for the presence and conservation status of Identification labels	O						
250h / 3m	Parking brake	O						
250h / 3m	Deadman seat microswitch	O						
250h / 3m	Emergency recovery pump (if any)	O						
250h / 3m	Emergency recovery button on joystick	O						
250h / 3m	Deadman joystick button	O						
250h / 3m	Reverse gear engaged acoustic signal	O						
250h / 3m	Three operation mode steering	O						
250h / 3m	Spirit level indication	O						
250h / 2m	Installed equipment working mode correct operation check	O						
250h / 2m	Emergency stop button operation check	O						
250h / 2m	Operation check consistent with the instructions in the cab	O						
400h / 3m	Chains (if any) coupling points, wear and adjustment	O		O			O	
400h / 3m	Forks (if present)	O						
500h / 6m	Hydraulic system maximum pressure	O						
500h / 6m	Power steering calibration pressure	O						
500h / 6m	Jacks block valves	O						

Notes	Stamp and signature



CONTROL LOG			
Control sheet no.	.....	Control date	.....
Vehicle serial number:	.....	Controller technician name	.....
Vehicle hours	.....	Controller company name	.....

	Controls							
250h / 3m	Longitudinal load momentum indicator check	O						
250h / 3m	Audible tipping alarm	O						
250h / 3m	Visual tipping warning	O						
250h / 3m	Anti-tipping system movements block	O						
250h / 3m	Seat belts	O						
250h / 3m	Control over the vehicle \ equipment for the presence and status of conservation of Safety Stickers	O						
250h / 3m	Control over the vehicle \ equipment for the presence and conservation status of Capacity Diagrams	O						
250h / 3m	Control over the vehicle \ equipment for the presence and conservation status of the Use and maintenance manual	O						
250h / 3m	Control over the vehicle \ equipment for the presence and conservation status of Identification labels	O						
250h / 3m	Parking brake	O						
250h / 3m	Deadman seat microswitch	O						
250h / 3m	Emergency recovery pump (if any)	O						
250h / 3m	Emergency recovery button on joystick	O						
250h / 3m	Deadman joystick button	O						
250h / 3m	Reverse gear engaged acoustic signal	O						
250h / 3m	Three operation mode steering	O						
250h / 3m	Spirit level indication	O						
250h / 2m	Installed equipment working mode correct operation check	O						
250h / 2m	Emergency stop button operation check	O						
250h / 2m	Operation check consistent with the instructions in the cab	O						
400h / 3m	Chains (if any) coupling points, wear and adjustment	O		O			O	
400h / 3m	Forks (if present)	O						
500h / 6m	Hydraulic system maximum pressure	O						
500h / 6m	Power steering calibration pressure	O						
500h / 6m	Jacks block valves	O						







Notes	Stamp and signature

## 23.6 - Maintenance log







The following are some sheets for filling in the Maintenance Log for fixed vehicles.

MAINTENANCE LOG			
Maintenance sheet no.	.....	Maintenance date	.....
Vehicle serial number:	.....	Maintenance technician name	.....
Vehicle hours	.....	Maintenance company name	.....

	Maintenance							
0h	Air conditioning system	<input type="checkbox"/>			<input type="checkbox"/>			
0h	Anti-tipping device inspection with load	<input type="checkbox"/>						
0h	Filters (air, engine oil, hydraulic oil, fuel, air conditioning system, cab)	<input type="checkbox"/>						
0h	Brake			<input type="checkbox"/>				
0h	Parking brake	<input type="checkbox"/>						
0h	Electrolyte level and battery charge	<input type="checkbox"/>						
0h	Lighting	<input type="checkbox"/>						
0h	Hydraulic oil level	<input type="checkbox"/>						
0h	Alternator belts \ services	<input type="checkbox"/>						
0h	Engine oil level	<input type="checkbox"/>						
0h	Radiators	<input type="checkbox"/>			<input type="checkbox"/>			
0h	Radiator expansion tank	<input type="checkbox"/>	<input type="checkbox"/>					
0h	Tyre pressure	<input type="checkbox"/>						
0h	Wear check (on both the vehicle and equipment if installed)	<input type="checkbox"/>						
10h / 1m	Window washer tank	<input type="checkbox"/>	<input type="checkbox"/>					
10h / 1m	Boom chains (if installed)	<input type="checkbox"/>						
10h / 1m	Safety stickers	<input type="checkbox"/>						
10h / 1m	Safety devices	<input type="checkbox"/>						
10h / 1m	Coolant	<input type="checkbox"/>						
10h / 1m	Engine oil level	<input type="checkbox"/>						
10h / 1m	Metal structural work, no cracks	<input type="checkbox"/>						
10h / 1m	Radiators				<input type="checkbox"/>			
50h / 1m	Grease level in the automatic lubrication system (if installed)						<input type="checkbox"/>	
50h / 1m	Prop shafts						<input type="checkbox"/>	
50h / 1m	Axles oscillation						<input type="checkbox"/>	
50h / 1m	Wheels reduction gear pins						<input type="checkbox"/>	
50h / 1m	Ropes and chains (if installed)	<input type="checkbox"/>					<input type="checkbox"/>	
50h / 1m	Wear pads	<input type="checkbox"/>					<input type="checkbox"/>	
50h / 1m	Mechanical joints of parking brake on the axle						<input type="checkbox"/>	
50h / 1m	Mechanical joints						<input type="checkbox"/>	
50h / 1m	Cab ventilation filter				<input type="checkbox"/>			
50h / 1m	Brakes oil level	<input type="checkbox"/>						
50h / 1m	Hydraulic oil level	<input type="checkbox"/>						
50h / 1m	Hydraulic system leaks	<input type="checkbox"/>						
50h / 1m	Air filter				<input type="checkbox"/>			

	Maintenance							
50h / 1m	Fuel filter				o			
50h / 1m	Coolant	o						
50h / 1m	Engine oil level	o						
50h / 1m	Tyre pressure	o						
50h / 1m	Wheel nuts tightening	o						
50h / 1m	Inching oil level (only PS transmissions)	o						
First 100h	Differential axle oil					o		
250h / 2m	Ropes and chains (if any) coupling points, wear and adjustment	o		o			o	
250h / 2m	Boom chains (if installed)			o				
250h / 2m	Seat belts	o						
250h / 2m	Rear view mirrors	o						
250h / 2m	Anti-tipping device	o						
250h / 2m	Electrolyte level and battery charge	o						
250h / 2m	Torque specifications - Hydraulic Fittings			o				
250h / 2m	Alternator belts \ services	o		o				
250h / 2m	Torque specifications - fasteners			o				
500h / 6m	PTO gearbox oil (if installed)					o		
500h / 6m	Differential axle oil	o						
500h / 6m	Epicycloidal reduction gear oil	o						
500h / 6m	Forks: wear	o						
500h / 6m	Cab ventilation filter					o		
500h / 6m	Brakes oil					o		
500h / 6m	Electrical system	o						
500h / 6m	Hydraulic oil filter(s)					o		
500h / 6m	Block valves	o						
500h / 6m	Air filter					o		
500h / 6m	FPT fuel filter					o		
500h / 6m	FPT engine oil filter					o		
500h / 6m	FPT engine oil					o		
500h / 6m	KUBOTA fuel filter					o		
500h / 6m	KUBOTA engine oil filter					o		
500h / 6m	KUBOTA engine oil					o		
500h / 6m	Transmission oil	o						
1000h / 1y	PTO gearbox oil (if installed)					o		
1000h / 1y	Differential axle oil					o		
1000h / 1y	Epicycloidal reduction gear oil					o		
1000h / 1y	Equipment condition	o						**
1000h / 1y	Forks support plate: wear	o						**

	Maintenance							
1000h / 1y	Telescopic boom: conditions	o						**
1000h / 1y	Telescopic boom: bearings and pivot bushes	o						**
1000h / 1y	Wear pads: wear	o						**
1000h / 1y	Cab structure	o						**
1000h / 1y	Brakes oil circuit				o			**
1000h / 1y	Brakes oil circuit: Pressure	o						**
1000h / 1y	Brake			o				**
1000h / 1y	Electrical system: cables condition	o						**
1000h / 1y	Electrical system: Lighting and signalling	o						**
1000h / 1y	Electrical system: Acoustic signal devices	o						**
1000h / 1y	Hydraulic system: Jacks	o						**
1000h / 1y	Hydraulic system: Pipes and flexible pipes	o						**
1000h / 1y	Hydraulic system: Movements speed	o						**
1000h / 1y	Hydraulic oil					o		
1000h / 1y	Engine valves clearances	o						**
1000h / 1y	Coolant					o		
1000h / 1y	Engine speeds	o						**
1000h / 1y	Fuel tank				o			
1000h / 1y	Wheels and tyres conditions	o						**
1000h / 1y	Chassis: bearings and pivot bushes	o						**
1000h / 1y	Chassis: structure	o						**
1000h / 1y	Transmission oil					o		
2000h	Axles oscillation	o						**
2000h	Ropes and chains (if installed)					o		**
2000h	Hydraulic system: Capacity	o						**
2000h	Hydraulic system: Pressures	o						**
2000h	Hydraulic oil tank				o			**
2000h	Alternator and Starter motor	o						**
2000h	Radiators	o			o			**
3600h	AdBlue tank filter FPT engine (only Stage IIIB/Tier 4i and Stage IV/ Tier 4f engine sizes)					o		**
4000h	Prop shafts	o				o		**
4000h	Reduction gears universal joint	o						**
4000h	Wheels reduction gear clearance	o						**
4000h	Steering ball joints	o						**
4000h	Wheels reduction gear pins	o						**
4000h	Brakes wear	o						**
2y	Air conditioning system (if installed): Dissipater filter					o		**
2y	Air conditioning system (if installed): Oil refrigerant	o						**
2y	Air conditioning system (if installed): Pressure switches	o		o				**
2y	Air conditioning system (if installed): Condenser and evaporator coils				o			**

Maintenance								
2y	Air conditioning system (if installed): Condensate and exhaust valve tank				o			**
Notes				Stamp and signature				







MAINTENANCE LOG			
Maintenance sheet no.	.....	Maintenance date	.....
Vehicle serial number:	.....	Maintenance technician name	.....
Vehicle hours	.....	Maintenance company name	.....

	Maintenance							
0h	Air conditioning system	o			o			
0h	Anti-tipping device inspection with load	o						
0h	Filters (air, engine oil, hydraulic oil, fuel, air conditioning system, cab)	o						
0h	Brake			o				
0h	Parking brake	o						
0h	Electrolyte level and battery charge	o						
0h	Lighting	o						
0h	Hydraulic oil level	o						
0h	Alternator belts \ services	o						
0h	Engine oil level	o						
0h	Radiators	o			o			
0h	Radiator expansion tank	o	o					
0h	Tyre pressure	o						
0h	Wear check (on both the vehicle and equipment if installed)	o						
10h / 1m	Window washer tank	o	o					
10h / 1m	Boom chains (if installed)	o						
10h / 1m	Safety stickers	o						
10h / 1m	Safety devices	o						
10h / 1m	Coolant	o						
10h / 1m	Engine oil level	o						
10h / 1m	Metal structural work, no cracks	o						
10h / 1m	Radiators				o			
50h / 1m	Grease level in the automatic lubrication system (if installed)							o
50h / 1m	Prop shafts							o
50h / 1m	Axles oscillation							o
50h / 1m	Wheels reduction gear pins							o
50h / 1m	Ropes and chains (if installed)	o						o
50h / 1m	Wear pads	o						o
50h / 1m	Mechanical joints of parking brake on the axle							o
50h / 1m	Mechanical joints							o
50h / 1m	Cab ventilation filter				o			
50h / 1m	Brakes oil level	o						
50h / 1m	Hydraulic oil level	o						
50h / 1m	Hydraulic system leaks	o						
50h / 1m	Air filter				o			



Maintenance								
50h / 1m	Fuel filter				o			
50h / 1m	Coolant	o						
50h / 1m	Engine oil level	o						
50h / 1m	Tyre pressure	o						
50h / 1m	Wheel nuts tightening	o						
50h / 1m	Inching oil level (only PS transmissions)	o						
First 100h	Differential axle oil					o		
250h / 2m	Ropes and chains (if any) coupling points, wear and adjustment	o		o			o	
250h / 2m	Boom chains (if installed)			o				
250h / 2m	Seat belts	o						
250h / 2m	Rear view mirrors	o						
250h / 2m	Anti-tipping device	o						
250h / 2m	Electrolyte level and battery charge	o						
250h / 2m	Torque specifications - Hydraulic Fittings			o				
250h / 2m	Alternator belts \ services	o		o				
250h / 2m	Torque specifications - fasteners			o				
500h / 6m	PTO gearbox oil (if installed)					o		
500h / 6m	Differential axle oil	o						
500h / 6m	Epicycloidal reduction gear oil	o						
500h / 6m	Forks: wear	o						
500h / 6m	Cab ventilation filter					o		
500h / 6m	Brakes oil					o		
500h / 6m	Electrical system	o						
500h / 6m	Hydraulic oil filter(s)					o		
500h / 6m	Block valves	o						
500h / 6m	Air filter					o		
500h / 6m	FPT fuel filter					o		
500h / 6m	FPT engine oil filter					o		
500h / 6m	FPT engine oil					o		
500h / 6m	KUBOTA fuel filter					o		
500h / 6m	KUBOTA engine oil filter					o		
500h / 6m	KUBOTA engine oil					o		
500h / 6m	Transmission oil	o						
1000h / 1y	PTO gearbox oil (if installed)					o		
1000h / 1y	Differential axle oil					o		
1000h / 1y	Epicycloidal reduction gear oil					o		
1000h / 1y	Equipment condition	o						**
1000h / 1y	Forks support plate: wear	o						**







	Maintenance							
1000h / 1y	Telescopic boom: conditions	o						**
1000h / 1y	Telescopic boom: bearings and pivot bushes	o						**
1000h / 1y	Wear pads: wear	o						**
1000h / 1y	Cab structure	o						**
1000h / 1y	Brakes oil circuit				o			**
1000h / 1y	Brakes oil circuit: Pressure	o						**
1000h / 1y	Brake			o				**
1000h / 1y	Electrical system: cables condition	o						**
1000h / 1y	Electrical system: Lighting and signalling	o						**
1000h / 1y	Electrical system: Acoustic signal devices	o						**
1000h / 1y	Hydraulic system: Jacks	o						**
1000h / 1y	Hydraulic system: Pipes and flexible pipes	o						**
1000h / 1y	Hydraulic system: Movements speed	o						**
1000h / 1y	Hydraulic oil					o		
1000h / 1y	Engine valves clearances	o						**
1000h / 1y	Coolant					o		
1000h / 1y	Engine speeds	o						**
1000h / 1y	Fuel tank				o			
1000h / 1y	Wheels and tyres conditions	o						**
1000h / 1y	Chassis: bearings and pivot bushes	o						**
1000h / 1y	Chassis: structure	o						**
1000h / 1y	Transmission oil					o		
2000h	Axles oscillation	o						**
2000h	Ropes and chains (if installed)					o		**
2000h	Hydraulic system: Capacity	o						**
2000h	Hydraulic system: Pressures	o						**
2000h	Hydraulic oil tank				o			**
2000h	Alternator and Starter motor	o						**
2000h	Radiators	o			o			**
3600h	AdBlue tank filter FPT engine (only Stage IIIB/Tier 4i and Stage IV/ Tier 4f engine sizes)					o		**
4000h	Prop shafts	o				o		**
4000h	Reduction gears universal joint	o						**
4000h	Wheels reduction gear clearance	o						**
4000h	Steering ball joints	o						**
4000h	Wheels reduction gear pins	o						**
4000h	Brakes wear	o						**
2y	Air conditioning system (if installed): Dissipater filter					o		**
2y	Air conditioning system (if installed): Oil refrigerant	o						**
2y	Air conditioning system (if installed): Pressure switches	o		o				**
2y	Air conditioning system (if installed): Condenser and evaporator coils				o			**







Maintenance								
2y	Air conditioning system (if installed): Condensate and exhaust valve tank				o			**
Notes				Stamp and signature				

MAINTENANCE LOG			
Maintenance sheet no.	.....	Maintenance date	.....
Vehicle serial number:	.....	Maintenance technician name	.....
Vehicle hours	.....	Maintenance company name	.....

	Maintenance							
0h	Air conditioning system	<input type="radio"/>			<input type="radio"/>			
0h	Anti-tipping device inspection with load	<input type="radio"/>						
0h	Filters (air, engine oil, hydraulic oil, fuel, air conditioning system, cab)	<input type="radio"/>						
0h	Brake			<input type="radio"/>				
0h	Parking brake	<input type="radio"/>						
0h	Electrolyte level and battery charge	<input type="radio"/>						
0h	Lighting	<input type="radio"/>						
0h	Hydraulic oil level	<input type="radio"/>						
0h	Alternator belts \ services	<input type="radio"/>						
0h	Engine oil level	<input type="radio"/>						
0h	Radiators	<input type="radio"/>			<input type="radio"/>			
0h	Radiator expansion tank	<input type="radio"/>	<input type="radio"/>					
0h	Tyre pressure	<input type="radio"/>						
0h	Wear check (on both the vehicle and equipment if installed)	<input type="radio"/>						
10h / 1m	Window washer tank	<input type="radio"/>	<input type="radio"/>					
10h / 1m	Boom chains (if installed)	<input type="radio"/>						
10h / 1m	Safety stickers	<input type="radio"/>						
10h / 1m	Safety devices	<input type="radio"/>						
10h / 1m	Coolant	<input type="radio"/>						
10h / 1m	Engine oil level	<input type="radio"/>						
10h / 1m	Metal structural work, no cracks	<input type="radio"/>						
10h / 1m	Radiators				<input type="radio"/>			
50h / 1m	Grease level in the automatic lubrication system (if installed)						<input type="radio"/>	
50h / 1m	Prop shafts						<input type="radio"/>	
50h / 1m	Axles oscillation						<input type="radio"/>	
50h / 1m	Wheels reduction gear pins						<input type="radio"/>	
50h / 1m	Ropes and chains (if installed)	<input type="radio"/>					<input type="radio"/>	
50h / 1m	Wear pads	<input type="radio"/>					<input type="radio"/>	
50h / 1m	Mechanical joints of parking brake on the axle						<input type="radio"/>	
50h / 1m	Mechanical joints						<input type="radio"/>	
50h / 1m	Cab ventilation filter				<input type="radio"/>			
50h / 1m	Brakes oil level	<input type="radio"/>						
50h / 1m	Hydraulic oil level	<input type="radio"/>						
50h / 1m	Hydraulic system leaks	<input type="radio"/>						
50h / 1m	Air filter				<input type="radio"/>			

Maintenance								
50h / 1m	Fuel filter				o			
50h / 1m	Coolant	o						
50h / 1m	Engine oil level	o						
50h / 1m	Tyre pressure	o						
50h / 1m	Wheel nuts tightening	o						
50h / 1m	Inching oil level (only PS transmissions)	o						
First 100h	Differential axle oil					o		
250h / 2m	Ropes and chains (if any) coupling points, wear and adjustment	o		o			o	
250h / 2m	Boom chains (if installed)			o				
250h / 2m	Seat belts	o						
250h / 2m	Rear view mirrors	o						
250h / 2m	Anti-tipping device	o						
250h / 2m	Electrolyte level and battery charge	o						
250h / 2m	Torque specifications - Hydraulic Fittings			o				
250h / 2m	Alternator belts \ services	o		o				
250h / 2m	Torque specifications - fasteners			o				
500h / 6m	PTO gearbox oil (if installed)					o		
500h / 6m	Differential axle oil	o						
500h / 6m	Epicycloidal reduction gear oil	o						
500h / 6m	Forks: wear	o						
500h / 6m	Cab ventilation filter					o		
500h / 6m	Brakes oil					o		
500h / 6m	Electrical system	o						
500h / 6m	Hydraulic oil filter(s)					o		
500h / 6m	Block valves	o						
500h / 6m	Air filter					o		
500h / 6m	FPT fuel filter					o		
500h / 6m	FPT engine oil filter					o		
500h / 6m	FPT engine oil					o		
500h / 6m	KUBOTA fuel filter					o		
500h / 6m	KUBOTA engine oil filter					o		
500h / 6m	KUBOTA engine oil					o		
500h / 6m	Transmission oil	o						
1000h / 1y	PTO gearbox oil (if installed)					o		
1000h / 1y	Differential axle oil					o		
1000h / 1y	Epicycloidal reduction gear oil					o		
1000h / 1y	Equipment condition	o						**
1000h / 1y	Forks support plate: wear	o						**







	Maintenance							
1000h / 1y	Telescopic boom: conditions	o						**
1000h / 1y	Telescopic boom: bearings and pivot bushes	o						**
1000h / 1y	Wear pads: wear	o						**
1000h / 1y	Cab structure	o						**
1000h / 1y	Brakes oil circuit				o			**
1000h / 1y	Brakes oil circuit: Pressure	o						**
1000h / 1y	Brake			o				**
1000h / 1y	Electrical system: cables condition	o						**
1000h / 1y	Electrical system: Lighting and signalling	o						**
1000h / 1y	Electrical system: Acoustic signal devices	o						**
1000h / 1y	Hydraulic system: Jacks	o						**
1000h / 1y	Hydraulic system: Pipes and flexible pipes	o						**
1000h / 1y	Hydraulic system: Movements speed	o						**
1000h / 1y	Hydraulic oil					o		
1000h / 1y	Engine valves clearances	o						**
1000h / 1y	Coolant					o		
1000h / 1y	Engine speeds	o						**
1000h / 1y	Fuel tank				o			
1000h / 1y	Wheels and tyres conditions	o						**
1000h / 1y	Chassis: bearings and pivot bushes	o						**
1000h / 1y	Chassis: structure	o						**
1000h / 1y	Transmission oil					o		
2000h	Axles oscillation	o						**
2000h	Ropes and chains (if installed)					o		**
2000h	Hydraulic system: Capacity	o						**
2000h	Hydraulic system: Pressures	o						**
2000h	Hydraulic oil tank				o			**
2000h	Alternator and Starter motor	o						**
2000h	Radiators	o			o			**
3600h	AdBlue tank filter FPT engine (only Stage IIIB/Tier 4i and Stage IV/ Tier 4f engine sizes)					o		**
4000h	Prop shafts	o				o		**
4000h	Reduction gears universal joint	o						**
4000h	Wheels reduction gear clearance	o						**
4000h	Steering ball joints	o						**
4000h	Wheels reduction gear pins	o						**
4000h	Brakes wear	o						**
2y	Air conditioning system (if installed): Dissipater filter					o		**
2y	Air conditioning system (if installed): Oil refrigerant	o						**
2y	Air conditioning system (if installed): Pressure switches	o		o				**
2y	Air conditioning system (if installed): Condenser and evaporator coils				o			**

Maintenance								
2y	Air conditioning system (if installed): Condensate and exhaust valve tank				o			**
Notes				Stamp and signature				









MAINTENANCE LOG			
Maintenance sheet no.	.....	Maintenance date	.....
Vehicle serial number:	.....	Maintenance technician name	.....
Vehicle hours	.....	Maintenance company name	.....

	Maintenance							
0h	Air conditioning system	<input type="checkbox"/>			<input type="checkbox"/>			
0h	Anti-tipping device inspection with load	<input type="checkbox"/>						
0h	Filters (air, engine oil, hydraulic oil, fuel, air conditioning system, cab)	<input type="checkbox"/>						
0h	Brake			<input type="checkbox"/>				
0h	Parking brake	<input type="checkbox"/>						
0h	Electrolyte level and battery charge	<input type="checkbox"/>						
0h	Lighting	<input type="checkbox"/>						
0h	Hydraulic oil level	<input type="checkbox"/>						
0h	Alternator belts \ services	<input type="checkbox"/>						
0h	Engine oil level	<input type="checkbox"/>						
0h	Radiators	<input type="checkbox"/>			<input type="checkbox"/>			
0h	Radiator expansion tank	<input type="checkbox"/>	<input type="checkbox"/>					
0h	Tyre pressure	<input type="checkbox"/>						
0h	Wear check (on both the vehicle and equipment if installed)	<input type="checkbox"/>						
10h / 1m	Window washer tank	<input type="checkbox"/>	<input type="checkbox"/>					
10h / 1m	Boom chains (if installed)	<input type="checkbox"/>						
10h / 1m	Safety stickers	<input type="checkbox"/>						
10h / 1m	Safety devices	<input type="checkbox"/>						
10h / 1m	Coolant	<input type="checkbox"/>						
10h / 1m	Engine oil level	<input type="checkbox"/>						
10h / 1m	Metal structural work, no cracks	<input type="checkbox"/>						
10h / 1m	Radiators				<input type="checkbox"/>			
50h / 1m	Grease level in the automatic lubrication system (if installed)						<input type="checkbox"/>	
50h / 1m	Prop shafts						<input type="checkbox"/>	
50h / 1m	Axles oscillation						<input type="checkbox"/>	
50h / 1m	Wheels reduction gear pins						<input type="checkbox"/>	
50h / 1m	Ropes and chains (if installed)	<input type="checkbox"/>					<input type="checkbox"/>	
50h / 1m	Wear pads	<input type="checkbox"/>					<input type="checkbox"/>	
50h / 1m	Mechanical joints of parking brake on the axle						<input type="checkbox"/>	
50h / 1m	Mechanical joints						<input type="checkbox"/>	
50h / 1m	Cab ventilation filter				<input type="checkbox"/>			
50h / 1m	Brakes oil level	<input type="checkbox"/>						
50h / 1m	Hydraulic oil level	<input type="checkbox"/>						
50h / 1m	Hydraulic system leaks	<input type="checkbox"/>						
50h / 1m	Air filter				<input type="checkbox"/>			

Maintenance								
50h / 1m	Fuel filter				o			
50h / 1m	Coolant	o						
50h / 1m	Engine oil level	o						
50h / 1m	Tyre pressure	o						
50h / 1m	Wheel nuts tightening	o						
50h / 1m	Inching oil level (only PS transmissions)	o						
First 100h	Differential axle oil					o		
250h / 2m	Ropes and chains (if any) coupling points, wear and adjustment	o		o			o	
250h / 2m	Boom chains (if installed)			o				
250h / 2m	Seat belts	o						
250h / 2m	Rear view mirrors	o						
250h / 2m	Anti-tipping device	o						
250h / 2m	Electrolyte level and battery charge	o						
250h / 2m	Torque specifications - Hydraulic Fittings			o				
250h / 2m	Alternator belts \ services	o		o				
250h / 2m	Torque specifications - fasteners			o				
500h / 6m	PTO gearbox oil (if installed)					o		
500h / 6m	Differential axle oil	o						
500h / 6m	Epicycloidal reduction gear oil	o						
500h / 6m	Forks: wear	o						
500h / 6m	Cab ventilation filter					o		
500h / 6m	Brakes oil					o		
500h / 6m	Electrical system	o						
500h / 6m	Hydraulic oil filter(s)					o		
500h / 6m	Block valves	o						
500h / 6m	Air filter					o		
500h / 6m	FPT fuel filter					o		
500h / 6m	FPT engine oil filter					o		
500h / 6m	FPT engine oil					o		
500h / 6m	KUBOTA fuel filter					o		
500h / 6m	KUBOTA engine oil filter					o		
500h / 6m	KUBOTA engine oil					o		
500h / 6m	Transmission oil	o						
1000h / 1y	PTO gearbox oil (if installed)					o		
1000h / 1y	Differential axle oil					o		
1000h / 1y	Epicycloidal reduction gear oil					o		
1000h / 1y	Equipment condition	o						**
1000h / 1y	Forks support plate: wear	o						**

	Maintenance							
1000h / 1y	Telescopic boom: conditions	o						**
1000h / 1y	Telescopic boom: bearings and pivot bushes	o						**
1000h / 1y	Wear pads: wear	o						**
1000h / 1y	Cab structure	o						**
1000h / 1y	Brakes oil circuit				o			**
1000h / 1y	Brakes oil circuit: Pressure	o						**
1000h / 1y	Brake			o				**
1000h / 1y	Electrical system: cables condition	o						**
1000h / 1y	Electrical system: Lighting and signalling	o						**
1000h / 1y	Electrical system: Acoustic signal devices	o						**
1000h / 1y	Hydraulic system: Jacks	o						**
1000h / 1y	Hydraulic system: Pipes and flexible pipes	o						**
1000h / 1y	Hydraulic system: Movements speed	o						**
1000h / 1y	Hydraulic oil					o		
1000h / 1y	Engine valves clearances	o						**
1000h / 1y	Coolant					o		
1000h / 1y	Engine speeds	o						**
1000h / 1y	Fuel tank				o			
1000h / 1y	Wheels and tyres conditions	o						**
1000h / 1y	Chassis: bearings and pivot bushes	o						**
1000h / 1y	Chassis: structure	o						**
1000h / 1y	Transmission oil					o		
2000h	Axles oscillation	o						**
2000h	Ropes and chains (if installed)					o		**
2000h	Hydraulic system: Capacity	o						**
2000h	Hydraulic system: Pressures	o						**
2000h	Hydraulic oil tank				o			**
2000h	Alternator and Starter motor	o						**
2000h	Radiators	o			o			**
3600h	AdBlue tank filter FPT engine (only Stage IIIB/Tier 4i and Stage IV/ Tier 4f engine sizes)					o		**
4000h	Prop shafts	o				o		**
4000h	Reduction gears universal joint	o						**
4000h	Wheels reduction gear clearance	o						**
4000h	Steering ball joints	o						**
4000h	Wheels reduction gear pins	o						**
4000h	Brakes wear	o						**
2y	Air conditioning system (if installed): Dissipater filter					o		**
2y	Air conditioning system (if installed): Oil refrigerant	o						**
2y	Air conditioning system (if installed): Pressure switches	o		o				**
2y	Air conditioning system (if installed): Condenser and evaporator coils				o			**

Maintenance								
2y	Air conditioning system (if installed): Condensate and exhaust valve tank				o			**
Notes		Stamp and signature						







MAINTENANCE LOG			
Maintenance sheet no.	.....	Maintenance date	.....
Vehicle serial number:	.....	Maintenance technician name	.....
Vehicle hours	.....	Maintenance company name	.....

	Maintenance							
0h	Air conditioning system	<input type="checkbox"/>			<input type="checkbox"/>			
0h	Anti-tipping device inspection with load	<input type="checkbox"/>						
0h	Filters (air, engine oil, hydraulic oil, fuel, air conditioning system, cab)	<input type="checkbox"/>						
0h	Brake			<input type="checkbox"/>				
0h	Parking brake	<input type="checkbox"/>						
0h	Electrolyte level and battery charge	<input type="checkbox"/>						
0h	Lighting	<input type="checkbox"/>						
0h	Hydraulic oil level	<input type="checkbox"/>						
0h	Alternator belts \ services	<input type="checkbox"/>						
0h	Engine oil level	<input type="checkbox"/>						
0h	Radiators	<input type="checkbox"/>			<input type="checkbox"/>			
0h	Radiator expansion tank	<input type="checkbox"/>	<input type="checkbox"/>					
0h	Tyre pressure	<input type="checkbox"/>						
0h	Wear check (on both the vehicle and equipment if installed)	<input type="checkbox"/>						
10h / 1m	Window washer tank	<input type="checkbox"/>	<input type="checkbox"/>					
10h / 1m	Boom chains (if installed)	<input type="checkbox"/>						
10h / 1m	Safety stickers	<input type="checkbox"/>						
10h / 1m	Safety devices	<input type="checkbox"/>						
10h / 1m	Coolant	<input type="checkbox"/>						
10h / 1m	Engine oil level	<input type="checkbox"/>						
10h / 1m	Metal structural work, no cracks	<input type="checkbox"/>						
10h / 1m	Radiators				<input type="checkbox"/>			
50h / 1m	Grease level in the automatic lubrication system (if installed)						<input type="checkbox"/>	
50h / 1m	Prop shafts						<input type="checkbox"/>	
50h / 1m	Axles oscillation						<input type="checkbox"/>	
50h / 1m	Wheels reduction gear pins						<input type="checkbox"/>	
50h / 1m	Ropes and chains (if installed)	<input type="checkbox"/>					<input type="checkbox"/>	
50h / 1m	Wear pads	<input type="checkbox"/>					<input type="checkbox"/>	
50h / 1m	Mechanical joints of parking brake on the axle						<input type="checkbox"/>	
50h / 1m	Mechanical joints						<input type="checkbox"/>	
50h / 1m	Cab ventilation filter				<input type="checkbox"/>			
50h / 1m	Brakes oil level	<input type="checkbox"/>						
50h / 1m	Hydraulic oil level	<input type="checkbox"/>						
50h / 1m	Hydraulic system leaks	<input type="checkbox"/>						
50h / 1m	Air filter				<input type="checkbox"/>			

Maintenance								
50h / 1m	Fuel filter				o			
50h / 1m	Coolant	o						
50h / 1m	Engine oil level	o						
50h / 1m	Tyre pressure	o						
50h / 1m	Wheel nuts tightening	o						
50h / 1m	Inching oil level (only PS transmissions)	o						
First 100h	Differential axle oil					o		
250h / 2m	Ropes and chains (if any) coupling points, wear and adjustment	o		o			o	
250h / 2m	Boom chains (if installed)			o				
250h / 2m	Seat belts	o						
250h / 2m	Rear view mirrors	o						
250h / 2m	Anti-tipping device	o						
250h / 2m	Electrolyte level and battery charge	o						
250h / 2m	Torque specifications - Hydraulic Fittings			o				
250h / 2m	Alternator belts \ services	o		o				
250h / 2m	Torque specifications - fasteners			o				
500h / 6m	PTO gearbox oil (if installed)					o		
500h / 6m	Differential axle oil	o						
500h / 6m	Epicycloidal reduction gear oil	o						
500h / 6m	Forks: wear	o						
500h / 6m	Cab ventilation filter					o		
500h / 6m	Brakes oil					o		
500h / 6m	Electrical system	o						
500h / 6m	Hydraulic oil filter(s)					o		
500h / 6m	Block valves	o						
500h / 6m	Air filter					o		
500h / 6m	FPT fuel filter					o		
500h / 6m	FPT engine oil filter					o		
500h / 6m	FPT engine oil					o		
500h / 6m	KUBOTA fuel filter					o		
500h / 6m	KUBOTA engine oil filter					o		
500h / 6m	KUBOTA engine oil					o		
500h / 6m	Transmission oil	o						
1000h / 1y	PTO gearbox oil (if installed)					o		
1000h / 1y	Differential axle oil					o		
1000h / 1y	Epicycloidal reduction gear oil					o		
1000h / 1y	Equipment condition	o						**
1000h / 1y	Forks support plate: wear	o						**

	Maintenance							
1000h / 1y	Telescopic boom: conditions	o						**
1000h / 1y	Telescopic boom: bearings and pivot bushes	o						**
1000h / 1y	Wear pads: wear	o						**
1000h / 1y	Cab structure	o						**
1000h / 1y	Brakes oil circuit				o			**
1000h / 1y	Brakes oil circuit: Pressure	o						**
1000h / 1y	Brake			o				**
1000h / 1y	Electrical system: cables condition	o						**
1000h / 1y	Electrical system: Lighting and signalling	o						**
1000h / 1y	Electrical system: Acoustic signal devices	o						**
1000h / 1y	Hydraulic system: Jacks	o						**
1000h / 1y	Hydraulic system: Pipes and flexible pipes	o						**
1000h / 1y	Hydraulic system: Movements speed	o						**
1000h / 1y	Hydraulic oil					o		
1000h / 1y	Engine valves clearances	o						**
1000h / 1y	Coolant					o		
1000h / 1y	Engine speeds	o						**
1000h / 1y	Fuel tank				o			
1000h / 1y	Wheels and tyres conditions	o						**
1000h / 1y	Chassis: bearings and pivot bushes	o						**
1000h / 1y	Chassis: structure	o						**
1000h / 1y	Transmission oil					o		
2000h	Axles oscillation	o						**
2000h	Ropes and chains (if installed)					o		**
2000h	Hydraulic system: Capacity	o						**
2000h	Hydraulic system: Pressures	o						**
2000h	Hydraulic oil tank				o			**
2000h	Alternator and Starter motor	o						**
2000h	Radiators	o			o			**
3600h	AdBlue tank filter FPT engine (only Stage IIIB/Tier 4i and Stage IV/ Tier 4f engine sizes)					o		**
4000h	Prop shafts	o				o		**
4000h	Reduction gears universal joint	o						**
4000h	Wheels reduction gear clearance	o						**
4000h	Steering ball joints	o						**
4000h	Wheels reduction gear pins	o						**
4000h	Brakes wear	o						**
2y	Air conditioning system (if installed): Dissipater filter					o		**
2y	Air conditioning system (if installed): Oil refrigerant	o						**
2y	Air conditioning system (if installed): Pressure switches	o		o				**
2y	Air conditioning system (if installed): Condenser and evaporator coils				o			**









Maintenance								
2y	Air conditioning system (if installed): Condensate and exhaust valve tank				o			**
Notes		Stamp and signature						

MAINTENANCE LOG			
Maintenance sheet no.	.....	Maintenance date	.....
Vehicle serial number:	.....	Maintenance technician name	.....
Vehicle hours	.....	Maintenance company name	.....

	Maintenance							
0h	Air conditioning system	<input type="checkbox"/>			<input type="checkbox"/>			
0h	Anti-tipping device inspection with load	<input type="checkbox"/>						
0h	Filters (air, engine oil, hydraulic oil, fuel, air conditioning system, cab)	<input type="checkbox"/>						
0h	Brake			<input type="checkbox"/>				
0h	Parking brake	<input type="checkbox"/>						
0h	Electrolyte level and battery charge	<input type="checkbox"/>						
0h	Lighting	<input type="checkbox"/>						
0h	Hydraulic oil level	<input type="checkbox"/>						
0h	Alternator belts \ services	<input type="checkbox"/>						
0h	Engine oil level	<input type="checkbox"/>						
0h	Radiators	<input type="checkbox"/>			<input type="checkbox"/>			
0h	Radiator expansion tank	<input type="checkbox"/>	<input type="checkbox"/>					
0h	Tyre pressure	<input type="checkbox"/>						
0h	Wear check (on both the vehicle and equipment if installed)	<input type="checkbox"/>						
10h / 1m	Window washer tank	<input type="checkbox"/>	<input type="checkbox"/>					
10h / 1m	Boom chains (if installed)	<input type="checkbox"/>						
10h / 1m	Safety stickers	<input type="checkbox"/>						
10h / 1m	Safety devices	<input type="checkbox"/>						
10h / 1m	Coolant	<input type="checkbox"/>						
10h / 1m	Engine oil level	<input type="checkbox"/>						
10h / 1m	Metal structural work, no cracks	<input type="checkbox"/>						
10h / 1m	Radiators				<input type="checkbox"/>			
50h / 1m	Grease level in the automatic lubrication system (if installed)						<input type="checkbox"/>	
50h / 1m	Prop shafts						<input type="checkbox"/>	
50h / 1m	Axles oscillation						<input type="checkbox"/>	
50h / 1m	Wheels reduction gear pins						<input type="checkbox"/>	
50h / 1m	Ropes and chains (if installed)	<input type="checkbox"/>					<input type="checkbox"/>	
50h / 1m	Wear pads	<input type="checkbox"/>					<input type="checkbox"/>	
50h / 1m	Mechanical joints of parking brake on the axle						<input type="checkbox"/>	
50h / 1m	Mechanical joints						<input type="checkbox"/>	
50h / 1m	Cab ventilation filter				<input type="checkbox"/>			
50h / 1m	Brakes oil level	<input type="checkbox"/>						
50h / 1m	Hydraulic oil level	<input type="checkbox"/>						
50h / 1m	Hydraulic system leaks	<input type="checkbox"/>						
50h / 1m	Air filter				<input type="checkbox"/>			







	Maintenance							
50h / 1m	Fuel filter				o			
50h / 1m	Coolant	o						
50h / 1m	Engine oil level	o						
50h / 1m	Tyre pressure	o						
50h / 1m	Wheel nuts tightening	o						
50h / 1m	Inching oil level (only PS transmissions)	o						
First 100h	Differential axle oil					o		
250h / 2m	Ropes and chains (if any) coupling points, wear and adjustment	o		o			o	
250h / 2m	Boom chains (if installed)			o				
250h / 2m	Seat belts	o						
250h / 2m	Rear view mirrors	o						
250h / 2m	Anti-tipping device	o						
250h / 2m	Electrolyte level and battery charge	o						
250h / 2m	Torque specifications - Hydraulic Fittings			o				
250h / 2m	Alternator belts \ services	o		o				
250h / 2m	Torque specifications - fasteners			o				
500h / 6m	PTO gearbox oil (if installed)					o		
500h / 6m	Differential axle oil	o						
500h / 6m	Epicycloidal reduction gear oil	o						
500h / 6m	Forks: wear	o						
500h / 6m	Cab ventilation filter					o		
500h / 6m	Brakes oil					o		
500h / 6m	Electrical system	o						
500h / 6m	Hydraulic oil filter(s)					o		
500h / 6m	Block valves	o						
500h / 6m	Air filter					o		
500h / 6m	FPT fuel filter					o		
500h / 6m	FPT engine oil filter					o		
500h / 6m	FPT engine oil					o		
500h / 6m	KUBOTA fuel filter					o		
500h / 6m	KUBOTA engine oil filter					o		
500h / 6m	KUBOTA engine oil					o		
500h / 6m	Transmission oil	o						
1000h / 1y	PTO gearbox oil (if installed)					o		
1000h / 1y	Differential axle oil					o		
1000h / 1y	Epicycloidal reduction gear oil					o		
1000h / 1y	Equipment condition	o						**
1000h / 1y	Forks support plate: wear	o						**

	Maintenance							
1000h / 1y	Telescopic boom: conditions	o						**
1000h / 1y	Telescopic boom: bearings and pivot bushes	o						**
1000h / 1y	Wear pads: wear	o						**
1000h / 1y	Cab structure	o						**
1000h / 1y	Brakes oil circuit				o			**
1000h / 1y	Brakes oil circuit: Pressure	o						**
1000h / 1y	Brake			o				**
1000h / 1y	Electrical system: cables condition	o						**
1000h / 1y	Electrical system: Lighting and signalling	o						**
1000h / 1y	Electrical system: Acoustic signal devices	o						**
1000h / 1y	Hydraulic system: Jacks	o						**
1000h / 1y	Hydraulic system: Pipes and flexible pipes	o						**
1000h / 1y	Hydraulic system: Movements speed	o						**
1000h / 1y	Hydraulic oil					o		
1000h / 1y	Engine valves clearances	o						**
1000h / 1y	Coolant					o		
1000h / 1y	Engine speeds	o						**
1000h / 1y	Fuel tank				o			
1000h / 1y	Wheels and tyres conditions	o						**
1000h / 1y	Chassis: bearings and pivot bushes	o						**
1000h / 1y	Chassis: structure	o						**
1000h / 1y	Transmission oil					o		
2000h	Axles oscillation	o						**
2000h	Ropes and chains (if installed)					o		**
2000h	Hydraulic system: Capacity	o						**
2000h	Hydraulic system: Pressures	o						**
2000h	Hydraulic oil tank				o			**
2000h	Alternator and Starter motor	o						**
2000h	Radiators	o			o			**
3600h	AdBlue tank filter FPT engine (only Stage IIIB/Tier 4i and Stage IV/ Tier 4f engine sizes)					o		**
4000h	Prop shafts	o				o		**
4000h	Reduction gears universal joint	o						**
4000h	Wheels reduction gear clearance	o						**
4000h	Steering ball joints	o						**
4000h	Wheels reduction gear pins	o						**
4000h	Brakes wear	o						**
2y	Air conditioning system (if installed): Dissipater filter					o		**
2y	Air conditioning system (if installed): Oil refrigerant	o						**
2y	Air conditioning system (if installed): Pressure switches	o		o				**
2y	Air conditioning system (if installed): Condenser and evaporator coils				o			**

Maintenance								
2y	Air conditioning system (if installed): Condensate and exhaust valve tank				o			**
Notes		Stamp and signature						







MAINTENANCE LOG			
Maintenance sheet no.	.....	Maintenance date	.....
Vehicle serial number:	.....	Maintenance technician name	.....
Vehicle hours	.....	Maintenance company name	.....

	Maintenance							
0h	Air conditioning system	<input type="checkbox"/>			<input type="checkbox"/>			
0h	Anti-tipping device inspection with load	<input type="checkbox"/>						
0h	Filters (air, engine oil, hydraulic oil, fuel, air conditioning system, cab)	<input type="checkbox"/>						
0h	Brake			<input type="checkbox"/>				
0h	Parking brake	<input type="checkbox"/>						
0h	Electrolyte level and battery charge	<input type="checkbox"/>						
0h	Lighting	<input type="checkbox"/>						
0h	Hydraulic oil level	<input type="checkbox"/>						
0h	Alternator belts \ services	<input type="checkbox"/>						
0h	Engine oil level	<input type="checkbox"/>						
0h	Radiators	<input type="checkbox"/>			<input type="checkbox"/>			
0h	Radiator expansion tank	<input type="checkbox"/>	<input type="checkbox"/>					
0h	Tyre pressure	<input type="checkbox"/>						
0h	Wear check (on both the vehicle and equipment if installed)	<input type="checkbox"/>						
10h / 1m	Window washer tank	<input type="checkbox"/>	<input type="checkbox"/>					
10h / 1m	Boom chains (if installed)	<input type="checkbox"/>						
10h / 1m	Safety stickers	<input type="checkbox"/>						
10h / 1m	Safety devices	<input type="checkbox"/>						
10h / 1m	Coolant	<input type="checkbox"/>						
10h / 1m	Engine oil level	<input type="checkbox"/>						
10h / 1m	Metal structural work, no cracks	<input type="checkbox"/>						
10h / 1m	Radiators				<input type="checkbox"/>			
50h / 1m	Grease level in the automatic lubrication system (if installed)						<input type="checkbox"/>	
50h / 1m	Prop shafts						<input type="checkbox"/>	
50h / 1m	Axles oscillation						<input type="checkbox"/>	
50h / 1m	Wheels reduction gear pins						<input type="checkbox"/>	
50h / 1m	Ropes and chains (if installed)	<input type="checkbox"/>					<input type="checkbox"/>	
50h / 1m	Wear pads	<input type="checkbox"/>					<input type="checkbox"/>	
50h / 1m	Mechanical joints of parking brake on the axle						<input type="checkbox"/>	
50h / 1m	Mechanical joints						<input type="checkbox"/>	
50h / 1m	Cab ventilation filter				<input type="checkbox"/>			
50h / 1m	Brakes oil level	<input type="checkbox"/>						
50h / 1m	Hydraulic oil level	<input type="checkbox"/>						
50h / 1m	Hydraulic system leaks	<input type="checkbox"/>						
50h / 1m	Air filter				<input type="checkbox"/>			







Maintenance								
50h / 1m	Fuel filter				o			
50h / 1m	Coolant	o						
50h / 1m	Engine oil level	o						
50h / 1m	Tyre pressure	o						
50h / 1m	Wheel nuts tightening	o						
50h / 1m	Inching oil level (only PS transmissions)	o						
First 100h	Differential axle oil					o		
250h / 2m	Ropes and chains (if any) coupling points, wear and adjustment	o		o			o	
250h / 2m	Boom chains (if installed)			o				
250h / 2m	Seat belts	o						
250h / 2m	Rear view mirrors	o						
250h / 2m	Anti-tipping device	o						
250h / 2m	Electrolyte level and battery charge	o						
250h / 2m	Torque specifications - Hydraulic Fittings			o				
250h / 2m	Alternator belts \ services	o		o				
250h / 2m	Torque specifications - fasteners			o				
500h / 6m	PTO gearbox oil (if installed)					o		
500h / 6m	Differential axle oil	o						
500h / 6m	Epicycloidal reduction gear oil	o						
500h / 6m	Forks: wear	o						
500h / 6m	Cab ventilation filter					o		
500h / 6m	Brakes oil					o		
500h / 6m	Electrical system	o						
500h / 6m	Hydraulic oil filter(s)					o		
500h / 6m	Block valves	o						
500h / 6m	Air filter					o		
500h / 6m	FPT fuel filter					o		
500h / 6m	FPT engine oil filter					o		
500h / 6m	FPT engine oil					o		
500h / 6m	KUBOTA fuel filter					o		
500h / 6m	KUBOTA engine oil filter					o		
500h / 6m	KUBOTA engine oil					o		
500h / 6m	Transmission oil	o						
1000h / 1y	PTO gearbox oil (if installed)					o		
1000h / 1y	Differential axle oil					o		
1000h / 1y	Epicycloidal reduction gear oil					o		
1000h / 1y	Equipment condition	o						**
1000h / 1y	Forks support plate: wear	o						**



	Maintenance							
1000h / 1y	Telescopic boom: conditions	o						**
1000h / 1y	Telescopic boom: bearings and pivot bushes	o						**
1000h / 1y	Wear pads: wear	o						**
1000h / 1y	Cab structure	o						**
1000h / 1y	Brakes oil circuit				o			**
1000h / 1y	Brakes oil circuit: Pressure	o						**
1000h / 1y	Brake			o				**
1000h / 1y	Electrical system: cables condition	o						**
1000h / 1y	Electrical system: Lighting and signalling	o						**
1000h / 1y	Electrical system: Acoustic signal devices	o						**
1000h / 1y	Hydraulic system: Jacks	o						**
1000h / 1y	Hydraulic system: Pipes and flexible pipes	o						**
1000h / 1y	Hydraulic system: Movements speed	o						**
1000h / 1y	Hydraulic oil					o		
1000h / 1y	Engine valves clearances	o						**
1000h / 1y	Coolant					o		
1000h / 1y	Engine speeds	o						**
1000h / 1y	Fuel tank				o			
1000h / 1y	Wheels and tyres conditions	o						**
1000h / 1y	Chassis: bearings and pivot bushes	o						**
1000h / 1y	Chassis: structure	o						**
1000h / 1y	Transmission oil					o		
2000h	Axles oscillation	o						**
2000h	Ropes and chains (if installed)					o		**
2000h	Hydraulic system: Capacity	o						**
2000h	Hydraulic system: Pressures	o						**
2000h	Hydraulic oil tank				o			**
2000h	Alternator and Starter motor	o						**
2000h	Radiators	o			o			**
3600h	AdBlue tank filter FPT engine (only Stage IIIB/Tier 4i and Stage IV/ Tier 4f engine sizes)					o		**
4000h	Prop shafts	o				o		**
4000h	Reduction gears universal joint	o						**
4000h	Wheels reduction gear clearance	o						**
4000h	Steering ball joints	o						**
4000h	Wheels reduction gear pins	o						**
4000h	Brakes wear	o						**
2y	Air conditioning system (if installed): Dissipater filter					o		**
2y	Air conditioning system (if installed): Oil refrigerant	o						**
2y	Air conditioning system (if installed): Pressure switches	o		o				**
2y	Air conditioning system (if installed): Condenser and evaporator coils				o			**







Maintenance								
2y	Air conditioning system (if installed): Condensate and exhaust valve tank				o			**
Notes		Stamp and signature						

MAINTENANCE LOG			
Maintenance sheet no.	.....	Maintenance date	.....
Vehicle serial number:	.....	Maintenance technician name	.....
Vehicle hours	.....	Maintenance company name	.....







	Maintenance							
0h	Air conditioning system	<input type="checkbox"/>			<input type="checkbox"/>			
0h	Anti-tipping device inspection with load	<input type="checkbox"/>						
0h	Filters (air, engine oil, hydraulic oil, fuel, air conditioning system, cab)	<input type="checkbox"/>						
0h	Brake			<input type="checkbox"/>				
0h	Parking brake	<input type="checkbox"/>						
0h	Electrolyte level and battery charge	<input type="checkbox"/>						
0h	Lighting	<input type="checkbox"/>						
0h	Hydraulic oil level	<input type="checkbox"/>						
0h	Alternator belts \ services	<input type="checkbox"/>						
0h	Engine oil level	<input type="checkbox"/>						
0h	Radiators	<input type="checkbox"/>			<input type="checkbox"/>			
0h	Radiator expansion tank	<input type="checkbox"/>	<input type="checkbox"/>					
0h	Tyre pressure	<input type="checkbox"/>						
0h	Wear check (on both the vehicle and equipment if installed)	<input type="checkbox"/>						
10h / 1m	Window washer tank	<input type="checkbox"/>	<input type="checkbox"/>					
10h / 1m	Boom chains (if installed)	<input type="checkbox"/>						
10h / 1m	Safety stickers	<input type="checkbox"/>						
10h / 1m	Safety devices	<input type="checkbox"/>						
10h / 1m	Coolant	<input type="checkbox"/>						
10h / 1m	Engine oil level	<input type="checkbox"/>						
10h / 1m	Metal structural work, no cracks	<input type="checkbox"/>						
10h / 1m	Radiators				<input type="checkbox"/>			
50h / 1m	Grease level in the automatic lubrication system (if installed)						<input type="checkbox"/>	
50h / 1m	Prop shafts						<input type="checkbox"/>	
50h / 1m	Axles oscillation						<input type="checkbox"/>	
50h / 1m	Wheels reduction gear pins						<input type="checkbox"/>	
50h / 1m	Ropes and chains (if installed)	<input type="checkbox"/>					<input type="checkbox"/>	
50h / 1m	Wear pads	<input type="checkbox"/>					<input type="checkbox"/>	
50h / 1m	Mechanical joints of parking brake on the axle						<input type="checkbox"/>	
50h / 1m	Mechanical joints						<input type="checkbox"/>	
50h / 1m	Cab ventilation filter				<input type="checkbox"/>			
50h / 1m	Brakes oil level	<input type="checkbox"/>						
50h / 1m	Hydraulic oil level	<input type="checkbox"/>						
50h / 1m	Hydraulic system leaks	<input type="checkbox"/>						
50h / 1m	Air filter				<input type="checkbox"/>			

	Maintenance							
50h / 1m	Fuel filter				o			
50h / 1m	Coolant	o						
50h / 1m	Engine oil level	o						
50h / 1m	Tyre pressure	o						
50h / 1m	Wheel nuts tightening	o						
50h / 1m	Inching oil level (only PS transmissions)	o						
First 100h	Differential axle oil					o		
250h / 2m	Ropes and chains (if any) coupling points, wear and adjustment	o		o			o	
250h / 2m	Boom chains (if installed)			o				
250h / 2m	Seat belts	o						
250h / 2m	Rear view mirrors	o						
250h / 2m	Anti-tipping device	o						
250h / 2m	Electrolyte level and battery charge	o						
250h / 2m	Torque specifications - Hydraulic Fittings			o				
250h / 2m	Alternator belts \ services	o		o				
250h / 2m	Torque specifications - fasteners			o				
500h / 6m	PTO gearbox oil (if installed)					o		
500h / 6m	Differential axle oil	o						
500h / 6m	Epicycloidal reduction gear oil	o						
500h / 6m	Forks: wear	o						
500h / 6m	Cab ventilation filter					o		
500h / 6m	Brakes oil					o		
500h / 6m	Electrical system	o						
500h / 6m	Hydraulic oil filter(s)					o		
500h / 6m	Block valves	o						
500h / 6m	Air filter					o		
500h / 6m	FPT fuel filter					o		
500h / 6m	FPT engine oil filter					o		
500h / 6m	FPT engine oil					o		
500h / 6m	KUBOTA fuel filter					o		
500h / 6m	KUBOTA engine oil filter					o		
500h / 6m	KUBOTA engine oil					o		
500h / 6m	Transmission oil	o						
1000h / 1y	PTO gearbox oil (if installed)					o		
1000h / 1y	Differential axle oil					o		
1000h / 1y	Epicycloidal reduction gear oil					o		
1000h / 1y	Equipment condition	o						**
1000h / 1y	Forks support plate: wear	o						**

	Maintenance							
1000h / 1y	Telescopic boom: conditions	o						**
1000h / 1y	Telescopic boom: bearings and pivot bushes	o						**
1000h / 1y	Wear pads: wear	o						**
1000h / 1y	Cab structure	o						**
1000h / 1y	Brakes oil circuit				o			**
1000h / 1y	Brakes oil circuit: Pressure	o						**
1000h / 1y	Brake			o				**
1000h / 1y	Electrical system: cables condition	o						**
1000h / 1y	Electrical system: Lighting and signalling	o						**
1000h / 1y	Electrical system: Acoustic signal devices	o						**
1000h / 1y	Hydraulic system: Jacks	o						**
1000h / 1y	Hydraulic system: Pipes and flexible pipes	o						**
1000h / 1y	Hydraulic system: Movements speed	o						**
1000h / 1y	Hydraulic oil					o		
1000h / 1y	Engine valves clearances	o						**
1000h / 1y	Coolant					o		
1000h / 1y	Engine speeds	o						**
1000h / 1y	Fuel tank				o			
1000h / 1y	Wheels and tyres conditions	o						**
1000h / 1y	Chassis: bearings and pivot bushes	o						**
1000h / 1y	Chassis: structure	o						**
1000h / 1y	Transmission oil					o		
2000h	Axles oscillation	o						**
2000h	Ropes and chains (if installed)					o		**
2000h	Hydraulic system: Capacity	o						**
2000h	Hydraulic system: Pressures	o						**
2000h	Hydraulic oil tank				o			**
2000h	Alternator and Starter motor	o						**
2000h	Radiators	o			o			**
3600h	AdBlue tank filter FPT engine (only Stage IIIB/Tier 4i and Stage IV/ Tier 4f engine sizes)					o		**
4000h	Prop shafts	o				o		**
4000h	Reduction gears universal joint	o						**
4000h	Wheels reduction gear clearance	o						**
4000h	Steering ball joints	o						**
4000h	Wheels reduction gear pins	o						**
4000h	Brakes wear	o						**
2y	Air conditioning system (if installed): Dissipater filter					o		**
2y	Air conditioning system (if installed): Oil refrigerant	o						**
2y	Air conditioning system (if installed): Pressure switches	o		o				**
2y	Air conditioning system (if installed): Condenser and evaporator coils				o			**

Maintenance								
2y	Air conditioning system (if installed): Condensate and exhaust valve tank				o			**
Notes				Stamp and signature				







MAINTENANCE LOG			
Maintenance sheet no.	.....	Maintenance date	.....
Vehicle serial number:	.....	Maintenance technician name	.....
Vehicle hours	.....	Maintenance company name	.....

	Maintenance							
0h	Air conditioning system	<input type="checkbox"/>			<input type="checkbox"/>			
0h	Anti-tipping device inspection with load	<input type="checkbox"/>						
0h	Filters (air, engine oil, hydraulic oil, fuel, air conditioning system, cab)	<input type="checkbox"/>						
0h	Brake			<input type="checkbox"/>				
0h	Parking brake	<input type="checkbox"/>						
0h	Electrolyte level and battery charge	<input type="checkbox"/>						
0h	Lighting	<input type="checkbox"/>						
0h	Hydraulic oil level	<input type="checkbox"/>						
0h	Alternator belts \ services	<input type="checkbox"/>						
0h	Engine oil level	<input type="checkbox"/>						
0h	Radiators	<input type="checkbox"/>			<input type="checkbox"/>			
0h	Radiator expansion tank	<input type="checkbox"/>	<input type="checkbox"/>					
0h	Tyre pressure	<input type="checkbox"/>						
0h	Wear check (on both the vehicle and equipment if installed)	<input type="checkbox"/>						
10h / 1m	Window washer tank	<input type="checkbox"/>	<input type="checkbox"/>					
10h / 1m	Boom chains (if installed)	<input type="checkbox"/>						
10h / 1m	Safety stickers	<input type="checkbox"/>						
10h / 1m	Safety devices	<input type="checkbox"/>						
10h / 1m	Coolant	<input type="checkbox"/>						
10h / 1m	Engine oil level	<input type="checkbox"/>						
10h / 1m	Metal structural work, no cracks	<input type="checkbox"/>						
10h / 1m	Radiators				<input type="checkbox"/>			
50h / 1m	Grease level in the automatic lubrication system (if installed)						<input type="checkbox"/>	
50h / 1m	Prop shafts						<input type="checkbox"/>	
50h / 1m	Axles oscillation						<input type="checkbox"/>	
50h / 1m	Wheels reduction gear pins						<input type="checkbox"/>	
50h / 1m	Ropes and chains (if installed)	<input type="checkbox"/>					<input type="checkbox"/>	
50h / 1m	Wear pads	<input type="checkbox"/>					<input type="checkbox"/>	
50h / 1m	Mechanical joints of parking brake on the axle						<input type="checkbox"/>	
50h / 1m	Mechanical joints						<input type="checkbox"/>	
50h / 1m	Cab ventilation filter				<input type="checkbox"/>			
50h / 1m	Brakes oil level	<input type="checkbox"/>						
50h / 1m	Hydraulic oil level	<input type="checkbox"/>						
50h / 1m	Hydraulic system leaks	<input type="checkbox"/>						
50h / 1m	Air filter				<input type="checkbox"/>			



Maintenance								
50h / 1m	Fuel filter				o			
50h / 1m	Coolant	o						
50h / 1m	Engine oil level	o						
50h / 1m	Tyre pressure	o						
50h / 1m	Wheel nuts tightening	o						
50h / 1m	Inching oil level (only PS transmissions)	o						
First 100h	Differential axle oil					o		
250h / 2m	Ropes and chains (if any) coupling points, wear and adjustment	o		o			o	
250h / 2m	Boom chains (if installed)			o				
250h / 2m	Seat belts	o						
250h / 2m	Rear view mirrors	o						
250h / 2m	Anti-tipping device	o						
250h / 2m	Electrolyte level and battery charge	o						
250h / 2m	Torque specifications - Hydraulic Fittings			o				
250h / 2m	Alternator belts \ services	o		o				
250h / 2m	Torque specifications - fasteners			o				
500h / 6m	PTO gearbox oil (if installed)					o		
500h / 6m	Differential axle oil	o						
500h / 6m	Epicycloidal reduction gear oil	o						
500h / 6m	Forks: wear	o						
500h / 6m	Cab ventilation filter					o		
500h / 6m	Brakes oil					o		
500h / 6m	Electrical system	o						
500h / 6m	Hydraulic oil filter(s)					o		
500h / 6m	Block valves	o						
500h / 6m	Air filter					o		
500h / 6m	FPT fuel filter					o		
500h / 6m	FPT engine oil filter					o		
500h / 6m	FPT engine oil					o		
500h / 6m	KUBOTA fuel filter					o		
500h / 6m	KUBOTA engine oil filter					o		
500h / 6m	KUBOTA engine oil					o		
500h / 6m	Transmission oil	o						
1000h / 1y	PTO gearbox oil (if installed)					o		
1000h / 1y	Differential axle oil					o		
1000h / 1y	Epicycloidal reduction gear oil					o		
1000h / 1y	Equipment condition	o						**
1000h / 1y	Forks support plate: wear	o						**







	Maintenance							
1000h / 1y	Telescopic boom: conditions	o						**
1000h / 1y	Telescopic boom: bearings and pivot bushes	o						**
1000h / 1y	Wear pads: wear	o						**
1000h / 1y	Cab structure	o						**
1000h / 1y	Brakes oil circuit				o			**
1000h / 1y	Brakes oil circuit: Pressure	o						**
1000h / 1y	Brake			o				**
1000h / 1y	Electrical system: cables condition	o						**
1000h / 1y	Electrical system: Lighting and signalling	o						**
1000h / 1y	Electrical system: Acoustic signal devices	o						**
1000h / 1y	Hydraulic system: Jacks	o						**
1000h / 1y	Hydraulic system: Pipes and flexible pipes	o						**
1000h / 1y	Hydraulic system: Movements speed	o						**
1000h / 1y	Hydraulic oil					o		
1000h / 1y	Engine valves clearances	o						**
1000h / 1y	Coolant					o		
1000h / 1y	Engine speeds	o						**
1000h / 1y	Fuel tank				o			
1000h / 1y	Wheels and tyres conditions	o						**
1000h / 1y	Chassis: bearings and pivot bushes	o						**
1000h / 1y	Chassis: structure	o						**
1000h / 1y	Transmission oil					o		
2000h	Axles oscillation	o						**
2000h	Ropes and chains (if installed)					o		**
2000h	Hydraulic system: Capacity	o						**
2000h	Hydraulic system: Pressures	o						**
2000h	Hydraulic oil tank				o			**
2000h	Alternator and Starter motor	o						**
2000h	Radiators	o			o			**
3600h	AdBlue tank filter FPT engine (only Stage IIIB/Tier 4i and Stage IV/ Tier 4f engine sizes)					o		**
4000h	Prop shafts	o				o		**
4000h	Reduction gears universal joint	o						**
4000h	Wheels reduction gear clearance	o						**
4000h	Steering ball joints	o						**
4000h	Wheels reduction gear pins	o						**
4000h	Brakes wear	o						**
2y	Air conditioning system (if installed): Dissipater filter					o		**
2y	Air conditioning system (if installed): Oil refrigerant	o						**
2y	Air conditioning system (if installed): Pressure switches	o		o				**
2y	Air conditioning system (if installed): Condenser and evaporator coils				o			**







Maintenance								
2y	Air conditioning system (if installed): Condensate and exhaust valve tank				o			**
Notes				Stamp and signature				

MAINTENANCE LOG			
Maintenance sheet no.	.....	Maintenance date	.....
Vehicle serial number:	.....	Maintenance technician name	.....
Vehicle hours	.....	Maintenance company name	.....

	Maintenance							
0h	Air conditioning system	<input type="checkbox"/>			<input type="checkbox"/>			
0h	Anti-tipping device inspection with load	<input type="checkbox"/>						
0h	Filters (air, engine oil, hydraulic oil, fuel, air conditioning system, cab)	<input type="checkbox"/>						
0h	Brake			<input type="checkbox"/>				
0h	Parking brake	<input type="checkbox"/>						
0h	Electrolyte level and battery charge	<input type="checkbox"/>						
0h	Lighting	<input type="checkbox"/>						
0h	Hydraulic oil level	<input type="checkbox"/>						
0h	Alternator belts \ services	<input type="checkbox"/>						
0h	Engine oil level	<input type="checkbox"/>						
0h	Radiators	<input type="checkbox"/>			<input type="checkbox"/>			
0h	Radiator expansion tank	<input type="checkbox"/>	<input type="checkbox"/>					
0h	Tyre pressure	<input type="checkbox"/>						
0h	Wear check (on both the vehicle and equipment if installed)	<input type="checkbox"/>						
10h / 1m	Window washer tank	<input type="checkbox"/>	<input type="checkbox"/>					
10h / 1m	Boom chains (if installed)	<input type="checkbox"/>						
10h / 1m	Safety stickers	<input type="checkbox"/>						
10h / 1m	Safety devices	<input type="checkbox"/>						
10h / 1m	Coolant	<input type="checkbox"/>						
10h / 1m	Engine oil level	<input type="checkbox"/>						
10h / 1m	Metal structural work, no cracks	<input type="checkbox"/>						
10h / 1m	Radiators				<input type="checkbox"/>			
50h / 1m	Grease level in the automatic lubrication system (if installed)						<input type="checkbox"/>	
50h / 1m	Prop shafts						<input type="checkbox"/>	
50h / 1m	Axles oscillation						<input type="checkbox"/>	
50h / 1m	Wheels reduction gear pins						<input type="checkbox"/>	
50h / 1m	Ropes and chains (if installed)	<input type="checkbox"/>					<input type="checkbox"/>	
50h / 1m	Wear pads	<input type="checkbox"/>					<input type="checkbox"/>	
50h / 1m	Mechanical joints of parking brake on the axle						<input type="checkbox"/>	
50h / 1m	Mechanical joints						<input type="checkbox"/>	
50h / 1m	Cab ventilation filter				<input type="checkbox"/>			
50h / 1m	Brakes oil level	<input type="checkbox"/>						
50h / 1m	Hydraulic oil level	<input type="checkbox"/>						
50h / 1m	Hydraulic system leaks	<input type="checkbox"/>						
50h / 1m	Air filter				<input type="checkbox"/>			

	Maintenance							
50h / 1m	Fuel filter				o			
50h / 1m	Coolant	o						
50h / 1m	Engine oil level	o						
50h / 1m	Tyre pressure	o						
50h / 1m	Wheel nuts tightening	o						
50h / 1m	Inching oil level (only PS transmissions)	o						
First 100h	Differential axle oil					o		
250h / 2m	Ropes and chains (if any) coupling points, wear and adjustment	o		o			o	
250h / 2m	Boom chains (if installed)			o				
250h / 2m	Seat belts	o						
250h / 2m	Rear view mirrors	o						
250h / 2m	Anti-tipping device	o						
250h / 2m	Electrolyte level and battery charge	o						
250h / 2m	Torque specifications - Hydraulic Fittings			o				
250h / 2m	Alternator belts \ services	o		o				
250h / 2m	Torque specifications - fasteners			o				
500h / 6m	PTO gearbox oil (if installed)					o		
500h / 6m	Differential axle oil	o						
500h / 6m	Epicycloidal reduction gear oil	o						
500h / 6m	Forks: wear	o						
500h / 6m	Cab ventilation filter					o		
500h / 6m	Brakes oil					o		
500h / 6m	Electrical system	o						
500h / 6m	Hydraulic oil filter(s)					o		
500h / 6m	Block valves	o						
500h / 6m	Air filter					o		
500h / 6m	FPT fuel filter					o		
500h / 6m	FPT engine oil filter					o		
500h / 6m	FPT engine oil					o		
500h / 6m	KUBOTA fuel filter					o		
500h / 6m	KUBOTA engine oil filter					o		
500h / 6m	KUBOTA engine oil					o		
500h / 6m	Transmission oil	o						
1000h / 1y	PTO gearbox oil (if installed)					o		
1000h / 1y	Differential axle oil					o		
1000h / 1y	Epicycloidal reduction gear oil					o		
1000h / 1y	Equipment condition	o						**
1000h / 1y	Forks support plate: wear	o						**

	Maintenance							
1000h / 1y	Telescopic boom: conditions	o						**
1000h / 1y	Telescopic boom: bearings and pivot bushes	o						**
1000h / 1y	Wear pads: wear	o						**
1000h / 1y	Cab structure	o						**
1000h / 1y	Brakes oil circuit				o			**
1000h / 1y	Brakes oil circuit: Pressure	o						**
1000h / 1y	Brake			o				**
1000h / 1y	Electrical system: cables condition	o						**
1000h / 1y	Electrical system: Lighting and signalling	o						**
1000h / 1y	Electrical system: Acoustic signal devices	o						**
1000h / 1y	Hydraulic system: Jacks	o						**
1000h / 1y	Hydraulic system: Pipes and flexible pipes	o						**
1000h / 1y	Hydraulic system: Movements speed	o						**
1000h / 1y	Hydraulic oil					o		
1000h / 1y	Engine valves clearances	o						**
1000h / 1y	Coolant					o		
1000h / 1y	Engine speeds	o						**
1000h / 1y	Fuel tank				o			
1000h / 1y	Wheels and tyres conditions	o						**
1000h / 1y	Chassis: bearings and pivot bushes	o						**
1000h / 1y	Chassis: structure	o						**
1000h / 1y	Transmission oil					o		
2000h	Axles oscillation	o						**
2000h	Ropes and chains (if installed)					o		**
2000h	Hydraulic system: Capacity	o						**
2000h	Hydraulic system: Pressures	o						**
2000h	Hydraulic oil tank				o			**
2000h	Alternator and Starter motor	o						**
2000h	Radiators	o			o			**
3600h	AdBlue tank filter FPT engine (only Stage IIIB/Tier 4i and Stage IV/ Tier 4f engine sizes)					o		**
4000h	Prop shafts	o				o		**
4000h	Reduction gears universal joint	o						**
4000h	Wheels reduction gear clearance	o						**
4000h	Steering ball joints	o						**
4000h	Wheels reduction gear pins	o						**
4000h	Brakes wear	o						**
2y	Air conditioning system (if installed): Dissipater filter					o		**
2y	Air conditioning system (if installed): Oil refrigerant	o						**
2y	Air conditioning system (if installed): Pressure switches	o		o				**
2y	Air conditioning system (if installed): Condenser and evaporator coils				o			**

Maintenance								
2y	Air conditioning system (if installed): Condensate and exhaust valve tank				o			**
Notes				Stamp and signature				





